

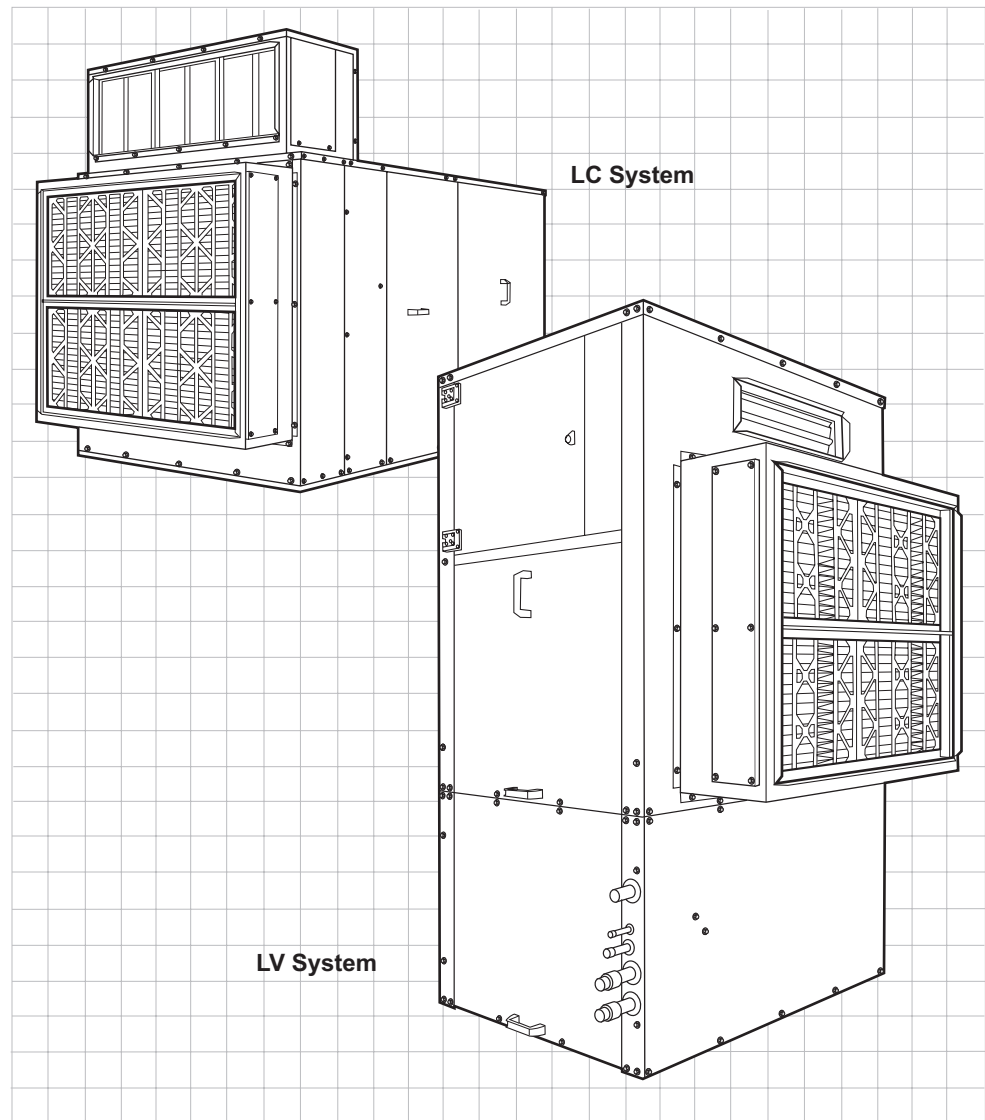

LC/LV/LCQ (ExpertAire™) Series Dehumidifiers

Installation and Operation Manual

- Meets AHRI Standard 910.
- Effective humidity control:
4 to 100 lbs per hour
- Wide range of ambient
temperatures: 65° to 95°F
- Air conditioning option
- Optional outdoor air intake
to help meet ASHRAE 62
ventilation requirements.
- Multiple heat sink options
including pool water
heating
- Scroll compressors for
high efficiency and
longevity
- Galvanneal cabinet with
high impact, powder coat
textured paint
- Auxiliary heat including
hot water and electric coils



! DANGER

ONLY TRAINED, QUALIFIED PERSONNEL SHOULD INSTALL AND/OR SERVICE DESERT AIRE EQUIPMENT. SERIOUS INJURY, DEATH AND PROPERTY DAMAGE CAN RESULT FROM IMPROPER INSTALLATION/SERVICE OF THIS EQUIPMENT. HIGH VOLTAGE ELECTRICAL COMPONENTS AND REFRIGERANT UNDER PRESSURE ARE PRESENT.

Desert Aire Dehumidification Equipment Standard Limited Warranty

Desert Aire warrants the dehumidifying unit to be free from defects in materials and workmanship subject to the terms, conditions and limitations stated herein.

TERMS

Desert Aire warrants all components (except as noted) for a period of one (1) year from the date of shipment contingent on validation of unit start-up by Desert Aire Service. Upon connection of the unit to Desert Aire's AireGuard™ remote access system via onboard Ethernet connection the warranty is extended one additional year for a total warranty period of two (2) years from date of shipment. This requires validation of unit start up by Desert Aire Service. This warranty shall be limited to the supply of new or rebuilt parts for the part which has failed because of defects in workmanship or material, and does not include the cost of labor, transportation or other costs not herein provided for. Replaced parts are warranted only for the remaining portion of the original warranty period.

CONDITIONS

The warranty is subject to the following conditions:

1. The unit must be properly installed and maintained in accordance with the Desert Aire "Installation and Operation Manual" provided with each unit and/or other documentation provided.
2. **The Start-up Report must be completed and returned to Desert Aire Service for evaluation. If no deficiencies are identified a Warranty Validation Letter will be issued that provides all warranty dates and coverage. If installation or start-up deficiencies are present, these must be corrected and communicated to Desert Aire in order to activate the warranty.**
3. This warranty shall not apply to any part that has been tampered with, or has been subject to misuse, negligence or accident. A warranty can be obtained for altered equipment but only with written consent from Desert Aire.
4. The following parts and components are excluded from the warranty: belts, filters, driers, fuses, pulleys and refrigerant.
5. Refrigerant coils or other components that corrode due to improperly balanced pool chemistry or corrosive air quality will not be warranted.
6. All replacements or repairs will be FOB Germantown, WI.
7. This warranty shall be null and void if defects or damages result from unauthorized opening of the refrigerant circuit, tampering with factory set controls, or operating outside the original design conditions. Desert Aire shall not be liable for labor costs incurred in diagnosing the problem, or the removal or replacement of the part or parts being repaired.
8. Desert Aire must preauthorize all warranty coverage described herein.

Extended Warranty:

Your Desert Aire unit may have extended warranties beyond this Standard Limited Warranty document.

Extended warranties are only available at the time of the purchase of the original equipment. These extended warranties are covered under a separate document and their terms and conditions are separate from this document. It is mentioned in this document for informational purposes only. Any Extended Warranties will be identified on the Warranty Validation Letter.

Any and all incidental or consequential damages are expressly excluded from this warranty. Some states do not allow the exclusion of incidental or consequential damages for personal injury, so the above limitations may not apply to you for certain damages. This warranty gives you specific legal rights, and you may also have other rights, which vary from state to state. No person or representative is authorized to make any warranty or assume any liability not strictly in accordance with the aforementioned.

Inquiries regarding warranty matters should be addressed to:

COMPANY: Desert Aire LLC
DEPARTMENT: Service Manager
ADDRESS: N120 W18485 Freistadt Road Germantown, WI 53022
OFFICE: (262) 946-7400
EMAIL: service@desert-aire.com

Additional copies of this manual can be purchased for a nominal fee from Desert Aire. Desert Aire also posts the most current revision of our I/O Manuals on our website. For a digital copy of the I/O Manual for your unit revision, please submit request to the contact information listed above.

Gas Heat Exchanger Ten (10)-Year Prorated Warranty Terms

Desert Aire offers an extended prorated eight (8)-year warranty for gas heat exchanger. All other heater components are covered under the initial 2-year warranty



For Your Safety Read Before Operating

WARNING

If you do not follow these instructions exactly a fire or explosion may result causing property damage, personal injury or loss of life.

- A. This appliance does not have a pilot. It is equipped with an ignition device that automatically lights the burner. Do not try to light the burner by hand.
- B. BEFORE OPERATING smell all around the appliance area for gas. Be sure to smell next to the floor because some gas is heavier than air and will settle on the floor.
WHAT TO DO IF YOU SMELL GAS
 - Do not try to light any appliance.
 - Do not touch any electric switch; do not use any phone in your building. Immediately call your gas supplier from a neighbor's phone. Follow the gas supplier's instructions.
 - If you cannot reach your gas supplier, call the fire department.
- C. Use only your hand to push in or turn the gas control knob. Never use tools. If the knob will not push in or turn by hand, don't try to repair it, call a qualified service technician. Force or attempted repair may result in a fire or explosion.
- D. Do not use this appliance if any part has been under water. Immediately call a qualified service technician to inspect the appliance and to replace any part of the control system and any gas control that has been under water.

OPERATING INSTRUCTIONS

1. STOP! Read the safety information above on this label.
2. Set the thermostat to lowest setting.
3. Turn off all electric power to the appliance.
4. This appliance is equipped with an ignition device that automatically lights the burner. Do not try to light the burner by hand.
5. Turn gas control knob clockwise  to "OFF" position.
6. Wait five (5) minutes to clear out any gas. Then smell for gas, including near the floor. If you smell gas, STOP! Follow "B" in the safety information above on this label. If you don't smell gas, go to next step.
7. Turn gas control knob counterclockwise  to "ON" position.
8. Turn on all electric power to unit.
9. Set thermostat to desired setting.
10. If appliance will not operate, follow the instructions "To Turn Off Gas To Appliance" and call your service technician or gas supplier.

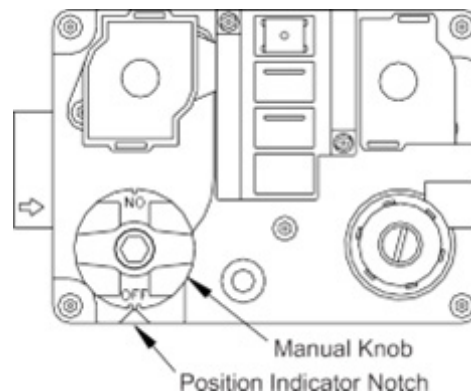



Figure 1: Gas Valve

TO TURN OFF GAS TO APPLIANCE

1. Set thermostat to lowest setting.
2. Turn off all electric power to the appliance if service is to be performed.
3. Turn gas control knob clockwise  to "OFF" position.

Dangers, Warnings, Cautions. This manual uses safety labels to show potential risks and necessary precautions. The labels comply with ANSI Z535.4 standards and incorporate ISO 7010 symbols for universal recognition. They are placed to ensure hazards are easily identified and understood.

Review entire manual BEFORE initiating equipment installation, operation, or service procedures.

 **DANGER**

Indicate the most severe and immediate consequences, warning installation professionals of situations that will result in fatal or catastrophic injury. These messages require immediate attention and strict compliance to prevent life-threatening outcomes.

 **WARNING**

Indicate the most severe potential consequences, warning installation professionals of situations that may result in fatal or catastrophic injury. These messages also require immediate attention and strict compliance to avoid life-threatening scenarios.

 **CAUTION**

Indicate hazardous conditions that may cause personal injury, equipment damage, or property-related incidents. These situations require careful attention and proactive safety measures to protect personnel and prevent operational or structural damage.

 **WARNING**

This product can expose you to chemicals including lead, which are known to the State of California to cause cancer and birth defects or other reproductive harm.

For more information go to www.P65Warnings.ca.gov

This warning is required by the State of California to meet Proposition 65 requirements.

TABLE OF CONTENTS

1.	ISO 7010 - Signs	13
1.1	Classification	13
1.2	Information	13
1.3	Prohibition	14
1.4	Mandatory	15
1.5	Hazard Warnings	16
2.	Equipment Safety	17
2.1	General Warnings and Safety	17
2.2	Warnings Concerning Flammable Refrigerants	18
2.3	Installation Safety	25
2.4	Service & Maintenance Safety	26
2.5	Equipment Lifecycle	27
2.5.1	Transport	27
2.5.2	Storage	27
2.5.3	Disposal/Recycle	28
3.	Minimum Room Size Requirements for A2L Refrigerants	28
3.1	Refrigerant Leak Detection and Mitigation	31
3.2	Determination of Room Area	33
3.3	Opening Conditions for Connected Rooms and Natural Ventilation	34
3.4	Opening Requirements for Mechanical Ventilation	36
3.5	Unventilated Room	37
3.6	Unventilated Room with Circulation Airflow	38
3.7	Natural Ventilation Between Conditioned Spaces	40
3.8	Natural Ventilation of Machine Room to Outdoors	41
3.9	Mechanical Ventilation Between Conditioned Spaces	43
3.10	Mechanical Ventilation of Machine Room to Outdoors	46
4.	Introduction	47
4.1	Inspection	47
4.2	Freight Damage Claims	47
4.3	Rigging	47
4.4	Rigging of Dehumidifier	48
4.4.1	Rigging the Remote Condenser	49
4.5	Operating Range	50
4.5.1	Unit Conversion	50
5.	Installation	51
5.1	Location of Dehumidifier	51
5.2	Duct Installation	53
5.3	Condensate Drain Piping	56
5.4	Water Heating Applications	58
5.4.1	Water Piping Connections	58

5.5	Remote Condenser (Optional)	61
5.6	Unit Factory Refrigerant Charge (Lbs.)	61
5.7	High Voltage Wiring	63
5.7.1	High Voltage Connections	64
5.7.2	Wire and Fuse Sizing	64
5.8	Controls and Sensors	64
5.8.1	Wall Mount Sensor	64
5.8.2	Return Air Sensor	64
5.9	Auxiliary Heating Control Wiring	65
5.9.1	Auxiliary Heating – Dry Contact Closure	65
5.9.2	Auxiliary Heating – Proportional Signal	65
5.10	Smoke Alarm Interlock	65
5.11	Gas Heater (Optional)	65
5.11.1	Gas Heater Installation	65
5.11.2	Gas Piping	66
5.11.3	Gas Heater Location	70
5.12	Electric Heater (Optional) For Packaged Product	71
5.13	Auxiliary Heat Coil Piping (Optional)	71
5.14	Roof Curb w/ Wood Nailer (if applicable)	72
6.	Start-up Procedure	73
6.1	Preliminary Inspection	73
6.2	Gas Heater Start-up (Optional)	74
6.2.1	Burner Adjustment	75
6.3	Outdoor Air Application	75
6.3.1	Outdoor Air Option Equipped Units	75
6.3.2	Standard Systems in Conjunction with Outdoor Air	77
6.3.3	Outdoor Air Supplemental Information	77
6.3.4	Determining if Outdoor Air Pre-Heating is Required	78
6.3.5	Approximating Outdoor Air Volume	78
6.4	Airflow Balancing	79
6.4.1	Units with an EC Blower	79
6.4.2	Blower Adjustment Procedure For Non-EC Blower Units	80
6.4.3	Airflow Balancing for LC Dehumidifiers Without EC Blower	80
6.4.4	Airflow Balancing for LV Dehumidifiers	81
6.5	Refrigeration Testing	83
6.6	General Testing	84
6.7	Routine Maintenance Schedule	85
6.7.1	Service Every Month	85
6.7.2	Service Every Six Months	85
6.7.3	Gas Heater (Optional)	85
6.7.4	Pool Water Chemistry	86
7.	Troubleshooting	86
7.1	The Blower Does Not Run	86
7.2	The Compressor Does Not Run	86

7.3	Evaporator Coil Ices Up	87
7.4	Head Pressure is Too High	87
7.5	Unit Runs but Excess Condensation on Walls and Windows	88
7.6	Pool Water Heating Problems (Water-Cooled Units Only)	89
8.	Appendix	89
8.1	Compressor Failure	89
	8.1.1 Compressor Replacement	89
8.2	Recommended Duct Design	92
8.3	System Guidelines	93
	8.3.1 Recommended Controller Settings	93
	8.3.2 Refrigeration System Pressures	93
	8.3.3 Temperature Rise or Drop Across Unit	93
8.4	Sequence of Operation	93
	8.4.1 Dehumidification and Air Reheat	93
	8.4.2 Dehumidification and Air Cooling	94
	8.4.3 Cooling and Water Heating (Water-Cooled Unit Only)	94
	8.4.4 Dehumidification and Water Heating (Water-Cooled Unit Only)	94
	8.4.5 Partial Pool or Spa Water Heating	94
	8.4.6 Operation of Water Condensers and Optional Pump Starts	94
	8.4.7 Blower Operation	95
	8.4.8 Air Heat (Optional)	95
	8.4.9 Outdoor Air (Outdoor Air Equipped Models Only)	95
8.5	Component Replacement, Charge, Evacuation, & Leak Instructions	95
8.6	Rating Plate	99
8.7	Start-up Supervision Supplemental Information (Optional)	99
8.8	Start-up System Report	100
	LC/LCQ/LV Start-up Request Form	101
	LC/LCQ/LV AireGuard Remote Start-up Assistance	104
	LC/LCQ/LV Series Start-up Report	105
	LC/LV Compressor Replacement Form	109

Table of Figures

Figure 1: Gas Valve	6
Figure 2: Flowchart for Conditioned Spaces	29
Figure 3: Flowchart for Machinery Room	30
Figure 4: Chart GG.7 - Required Opening (in ²) per Given Room Area (ft. ²)	34
Figure 5: Openings Above 300mm and Minimum Natural Ventilation Criteria	34
Figure 6: Minimum Natural Ventilation Opening Requirements Below 200mm	35
Figure 7: Height Regulations for the Lowest Opening in Installation	35
Figure 8: Minimum Height Requirement for Floor-Extending Openings	35
Figure 9: Opening Requirements for Mechanical Ventilation	36
Figure 10: Unventilated non-ducted unit	37
Figure 11: Air Duct Diagram for one or more rooms	38
Figure 12: Ducted unit with Natural Ventilation	40
Figure 13: Non-Ducted unit with Natural Ventilation	40
Figure 14: Natural Ventilation of Machinery Room to the Outdoors.....	41
Figure 15: Ducted Unit with Mechanical Ventilation Between Conditioned Spaces	43
Figure 16: Non-Ducted Unit with Mechanical Ventilation Between Conditioned Spaces	44
Figure 17: Mechanical Ventilation to Conditioned Spaces from Mechanical Room	44
Figure 18: Mechanical Ventilation of Machinery Room to Outdoors.....	46
Figure 19: Typical Rigging for Large Systems	48
Figure 20: Typical Rigging for an Optional Remote Condenser	49
Figure 21: Typical Floor Installation	51
Figure 22: Typical Suspended Installation - LC Only (LV Units are floor units only)	52
Figure 23: Basic Pool Room Layout	54
Figure 24: Soffit Duct Layout	55
Figure 25: Under-Foor Duct Layout	56
Figure 26: Condensate Piping	57
Figure 27: Sectional View of Condensate Trap Requirements	57
Figure 28: Proper Pool Water Heating Installation for Desert Aire LC and LV Dehumidifiers	59
Figure 29: Proper Pool Water Heating Installation for Desert Aire LV Dehumidifiers	60
Figure 30: Single-Phase and Three-Phase System Power Connection	64
Figure 31: Typical LP Gas Piping	69
Figure 32: Wood Nailer	72
Figure 33: Wood Nailer Detailed	72
Figure 34: Proper Installation for an Outdoor Air Application	76
Figure 35: LC Models left; LV Models right - Unoccupied Mode Operation	77
Figure 36: LC Models left; LV Models right - Occupied Mode Operation	77
Figure 37: Approximating Outdoor Air CFM	79
Figure 38: LC Air Balance Ports	80
Figure 39: LV Air Balance Ports	82
Figure 40: Recommended Duct Designs for Desert Aire Dehumidifiers	92
Figure 41: System Rating Plate	99

Table of Tables

Table 1: A2L Sensor Self Diagnostics	31
Table 2: Room Area Adjustment Factor	33
Table 3: Minimum Floor Area for Unventilated Room Non-Ducted Unit	37
Table 4: Minimum Area, and Airflow for Unventilated Room with Circulation Airflow	39
Table 5: Minimum Opening Area for Natural Ventilation of Machinery Room to the Outdoors	42
Table 6: Minimum Entering Area and Minimum Airflow for Mechanical Ventilation Between Conditioned Space and Mechanical Ventilation of Machine Room to the Outdoors	45
Table 7: Operating Range for Refrigerant Pressure, Altitude, Water Pressure and Temperature	50
Table 8: LC and LV Series Standard Unit Airflow Specifications	53

Table 9: Standard Unit Water Flow Rates for LC and LV Units 58

Table 10: Unit Factory Charge 61

Table 11: Standard RCD Series Remote Condenser Line Sizes and Additional Charge 62

Table 12: Standard RCD Series Remote Condenser Line Sizes and Additional Charge 63

Table 13: Gas Pipe Capacity in Cubic Feet per Hour 67

Table 14: Gas Connection Sizes 68

Table 15: LP Gas Pipe Sizing Information 69

Table 16: Specified Belt Deflection Table 73

Table 17: Belt Deflection Force Table 74

Table 18: Standard Reheat Coil Pressure Drops 82

Table 19: Evaporator Pressure Drop 83





Table 20: Superheat Minimum Values Chart 84

Table 21: Grease Suggested Brands and Types 85





Table 22: Provide the Following Information When Contacting Desert Aire Service Department 86

1. ISO 7010 - Signs







1.1 Classification

	<p>Mandatory action required where ignoring mandatory action can result in property damage, significant injury, and/ or death.</p>		<p>Prohibited Action. You must never perform the action shown or described.</p>
	<p>General Hazard warning where if the corresponding precautions are not taken it could result in significant property damage, severe injury and / or death.</p>		<p>Important additional information and advice for user.</p>









1.2 Information

	<p>Before installation, start-up, and service, read these instructions carefully to ensure correct use. Use this manual to work safely with and on the equipment. They contain safety instructions that must be complied with as well as information required for optimal performance of the equipment. Failure to follow instructions can result in significant property damage, severe injury and / or death.</p>		<p>Before operating equipment read these instructions carefully. They contain safety instructions and hazard warnings that must be complied with. Failure to follow instructions can result in significant property damage, severe injury and / or death.</p>
	<p>Protective Earth IEC 60417-2019 Located near customer ground connection</p>		<p>CLASS 2</p>













1.3 Prohibition

	<p>Do not step on this surface. It is not designed to support weight and may result in injury or damage.</p>		<p>Warning Fire Hazard Keep this area free of open containers with flammable liquids or combustible vapors.</p>
	<p>Health Hazard, Equipment contains refrigerants, oils, and hazardous chemical substances. Prolonged or repeated exposure may cause severe respiratory damage.</p>		<p>No open flame near this equipment. Open flames may cause fire or explosion hazards.</p>
	<p>WARNING: Environmental Protection - Chemical Disposal Protocol</p> <p>Prohibited: discharge of refrigerants, oils, or chemical substances into municipal wastewater systems, ground-water sources, or natural water bodies.</p> <p>Mandatory action: comply strictly with local environmental regulations. Use certified hazardous waste disposal facilities and document all chemical disposal procedures. Unauthorized disposal violates environmental protection laws and will result in immediate legal and environmental consequences.</p>		<p>Do not stand under any load. Falling objects can result in severe injury or death.</p>
			<p>Never operate the equipment with doors or covers removed. Access to hazardous voltage and moving parts can result in significant property damage, severe injury, and / or death.</p>
			<p>Equipment contains flammable gas. No smoking, no open flames, and no sparks. Ignoring this warning can lead to fire or explosion.</p>

1.4 Mandatory

	<p>Lock Electrical Disconnect Switch or Circuit Breaker supplying the equipment when opening any access doors or covers. Follow Lock Out - Tag Out protocol when servicing equipment.</p>		<p>This equipment has high leakage current. Ensure a protective earth connection is established before connecting the main supply. Minimum ground wire size: 8.4 mm² Cu.</p>
	<p>Disconnect all incoming sources of power before opening any access doors or covers on the equipment.</p>		<p>Ensure proper equipotential bonding is established to eliminate potential differences and enhance safety during operation.</p>
	<p>Wear protective gloves. Equipment can contain contaminated refrigerant and oil which can cause severe burns.</p>		<p>Lift point: Use designated lift points when handling the unit. Ensure all lifting operations comply with equipment specifications and safety guidelines.</p>
	<p>Wear eye protection when servicing equipment containing refrigerants, which can be hazardous.</p>		<p>Lifting equipment must be used whenever the unit is moved to prevent injury or damage.</p>

1.5 Hazard Warnings

	<p>WARNING: This equipment contains hazardous voltage and live electrical parts. Contact with these parts can result in severe injury or death. Take all necessary precautions to avoid contact with live parts.</p>		<p>Units equipped with the CO₂ option have associated CO₂-specific hazards. Correct installation, selection of alarms, warnings, and safety components is required. Failure to comply may result in injury or death.</p>
	<p>The unit contains an electronically commutated motor that retains hazardous voltage even after power is disconnected. Wait at least three (3) minutes after disconnecting power before servicing motors or electrical components in the remote condenser unit. Sealed electrical components must be replaced if damaged or faulty. Intrinsically safe components must be replaced if required to maintain safety integrity.</p>		<p>WARNING: equipment contains refrigerant gas that can be under high pressure. Only qualified, trained, and licensed person(s) should open the refrigeration circuit with authorization from the manufacturer and following these instructions. Failure to do so can result in property damage, serious injury, and / or death.</p>
	<p>WARNING: This equipment poses a potential arc flash hazard. Use appropriate personal protective equipment (PPE) and tools when working on this equipment. Failure to comply may result in severe injury or death.</p>		<p>WARNING: This equipment may contain multiple supply mains connections with hazardous live voltage. Disconnect all supply connections before removing doors or covers. Failure to comply may result in severe injury or death.</p>
	<p>WARNING: Beware of overhead obstacles. Ensure proper clearance to avoid injury or damage.</p>		<p>WARNING: contact with rotating fan blades can result in significant property damage, severe injury, or death. Take all necessary precautions to avoid contact with rotating components.</p>
	<p>WARNING: Keep hands and loose items away from moving parts. Contact with rotating components can result in serious injury.</p>		<p>This equipment may contain substances or mixtures that pose a health hazard. Handle with care and follow all applicable safety guidelines.</p>
	<p>This equipment may have hot surfaces. Avoid contact to prevent burns.</p>		<p>Overhead loads may be present. Stay clear of the area to avoid injury or death</p>

2. Equipment Safety

The equipment must be installed, operated, and serviced/maintained in accordance with this manual and national and local codes. Only authorized and knowledgeable personnel may access the unit, and they must be qualified as specified by Annex HH of UL 60335-2-40 4th edition. Desert Aire is not liable for a personal harm, or material damage arising from failure to comply with this manual and national or local codes.

2.1 General Warnings and Safety

WARNING

- The appliance is not to be used by persons (including children) with reduced physical, sensory or mental capabilities, or lack of experience and knowledge, unless they have been given supervision or instruction.
 - Children should be supervised to ensure that they do not play with the appliance.
 - Do not use equipment in an explosive atmosphere, or with improperly balanced air chemistry or corrosive air quality that causes undue corrosion on refrigerant coils and other components.
 - Do not use equipment as a resting surface, climbing aid, or storage device.
 - Do not attempt unauthorized constructional modifications, unauthorized opening of the refrigeration circuit, tampering with the factory set controls, or operation outside the original design conditions.
 - HVAC liquids and chemicals can be dangerous if used incorrectly or if spills or accidents occur. Handle detergents and solvents with care to avoid spills and burns.

WARNING

- Do not attempt any electrical work if you are not a qualified/ licensed electrician or technician.
- Do not power the system using an extension cable or smaller than specified gauge wiring.
- Do not share the electrical supply mains with other appliances. Improper or insufficient power supply can cause undesirable operation, fire or electrical shock.
- For all electrical work follow all local and national wiring standards and regulations as well as this installation manual. You must use an independent overcurrent protection device to supply power.
- For all electrical work use the specified wiring.
- Ensure wiring connections are tight and clamped securely to prevent external forces from damaging the terminals. Improper connections can overheat and cause fire and/or electrical shock.

2.2 Warnings Concerning Flammable Refrigerants

WARNING

Risk of Fire – UNIT CONTAINS R-454B REFRIGERANT

Flammable Refrigerant Used

- To Be Repaired Only by Trained Service Personnel. Do Not Puncture Refrigerant Tubing.
- Dispose Of Properly in Accordance with Federal Or Local Regulations.
- Consult Repair Manual/Owner’s Guide before attempting to Service this Product. All Safety Precautions Must Be Followed.
- Follow Handling Instructions Carefully in Compliance with National Regulations.
- Auxiliary devices which may be ignition sources shall not be installed in the ductwork, other than auxiliary devices listed for use with the specific appliance. See instructions.
- Proper service equipment is required. Failure to use proper service tools may result in equipment damage or personal injury.
- Refrigerant cylinders can explode causing serious injury and/or death if not handled and stored properly.

WARNING

- Do not use means to accelerate the defrosting process or to clean, other than those recommended by the manufacturer.
- The appliance shall be stored in a room without continuously operating ignition sources (for example: open flames, an operating gas appliance or an operating electric heater).
- Do not pierce or burn. Be aware that refrigerants may not contain an odor.



Units with mildly flammable refrigerants (A2L), such as R-454B, shall be installed in accordance with all national and local regulations where applicable. The information below is provided in accordance with standard UL 60335-2-40 4th edition and its annexes and clauses.









(Annex DD.3.3) Qualification of Workers

Any operation concerning the installation, maintenance, repair, disassembly, and dismantling of the unit shall be carried out by qualified personnel, in accordance with Annex HH to the standard UL 60335-2-40 4th edition, who hold a valid certificate of compliance with the existing standards.

The above-mentioned operations include:

- Breaking into the refrigeration circuit;
- Opening of sealed components;
- Opening of ventilated enclosures.

(Annex DD.4) Information on Servicing	
	(Annex DD.4.2) Checks to the area Prior to beginning work on systems containing FLAMMABLE REFRIGERANTS, safety checks are necessary to ensure that the risk of ignition is minimized. For repair to the REFRIGERATING SYSTEM, DD.4.3 to DD.4.7 shall be completed prior to conducting work on the system.
	(Annex DD.4.3) Work procedure Work shall be undertaken under a controlled procedure so as to minimize the risk of a flammable gas or vapor being present while the work is being performed.
	(Annex DD.4.4) General work area All maintenance staff and others working in the local area shall be instructed on the nature of work being carried out. Work in confined spaces shall be avoided.
	(Annex DD.4.5) Checking for presence of refrigerant The area shall be checked with an appropriate refrigerant detector prior to and during work, to ensure the technician is aware of potentially toxic or flammable atmospheres. Ensure that the leak detection equipment being used is suitable for use with all applicable refrigerants, i.e. non-sparking, adequately sealed or intrinsically safe.
	(Annex DD.4.6) Presence of fire extinguisher If any hot work is to be conducted on the refrigerating equipment or any associated parts, appropriate fire extinguishing equipment shall be available to hand. Have a dry powder or CO2 fire extinguisher adjacent to the charging area.
	(Annex DD.4.7) No ignition sources No person carrying out work in relation to a REFRIGERATING SYSTEM which involves exposing any pipe work shall use any sources of ignition in such a manner that it may lead to the risk of fire or explosion. All possible ignition sources, including cigarette smoking, should be kept sufficiently far away from the site of installation, repairing, removing and disposal, during which refrigerant can possibly be released to the surrounding space. Prior to work taking place, the area around the equipment is to be surveyed to make sure that there are no flammable hazards or ignition risks. "No Smoking" signs shall be displayed.
	(Annex DD.4.8) Ventilated area Ensure that the area is in the open or that it is adequately ventilated before breaking into the system or conducting any hot work. A degree of ventilation shall continue during the period that the work is carried out. The ventilation should safely disperse any released refrigerant and preferably expel it externally into the atmosphere.

**(Annex DD.4.9) Checks to the refrigerating equipment**

Where electrical components are being changed, they shall be fit for the purpose and to the correct specification. At all times the manufacturer's maintenance and service guidelines shall be followed. If in doubt, consult the manufacturer's technical department for assistance.

The following checks shall be applied to installations using FLAMMABLE REFRIGERANTS:

- The actual REFRIGERANT CHARGE is in accordance with the room size within which the refrigerant containing parts are installed;
- The ventilation machinery and outlets are operating adequately and are not obstructed;
- If an indirect refrigerating circuit is being used, the secondary circuit shall be checked for the presence of refrigerant;
- Marking to the equipment continues to be visible and legible. Markings and signs that are illegible shall be corrected;
- Refrigerant pipe or components are installed in a position where they are unlikely to be exposed to any substance which may corrode refrigerant containing components, unless the components are constructed of materials which are inherently resistant to being corroded or are suitably protected against being so corroded.

**(Annex DD.4.10) Checks to electrical devices**

Repair and maintenance to electrical components shall include initial safety checks and component inspection procedures. If a fault exists that could compromise safety, then no electrical supply shall be connected to the circuit until it is satisfactorily dealt with. If the fault cannot be corrected immediately but it is necessary to continue operation, an adequate temporary solution shall be used. This shall be reported to the owner of the equipment so all parties are advised.

Initial safety checks shall include:

- That capacitors are discharged: this shall be done in a safe manner to avoid possibility of sparking;
- That no live electrical components and wiring are exposed while charging, recovering or purging the system;
- That there is continuity of earth bonding.

**(Annex DD.5) Repairs to sealed components**

Sealed electrical components shall be replaced.

**(Annex DD.6) Repairs to intrinsically safe components**

Intrinsically safe components must be replaced.

**(Annex DD.7) Cabling**

Check that cabling will not be subject to wear, corrosion, excessive pressure, vibration, sharp edges or any other adverse environmental effects. The check shall also take into account the effects of aging or continual vibration from sources such as compressors or fans.

**(Annex DD.8) Detection of flammable refrigerants**

Under no circumstances shall potential sources of ignition be used in the searching for or detection of refrigerant leaks. A halide torch (or any other detector using a naked flame) shall not be used.

The following leak detection methods are deemed acceptable for all refrigerant systems.

Electronic leak detectors may be used to detect refrigerant leaks but, in the case of FLAMMABLE REFRIGERANTS, the sensitivity may not be adequate or may need re-calibration. (Detection equipment shall be calibrated in a refrigerant-free area.) Ensure that the detector is not a potential source of ignition and is suitable for the refrigerant used. Leak detection equipment shall be set at a percentage of the LFL of the refrigerant and shall be calibrated to the refrigerant employed, and the appropriate percentage of gas (25 % maximum) is confirmed.

Leak detection fluids are also suitable for use with most refrigerants but the use of detergents containing chlorine shall be avoided as the chlorine may react with the refrigerant and corrode the copper pipework.

NOTE Examples of leak detection fluids are:

- bubble method,
- fluorescent method agents.

If a leak is suspected, all naked flames shall be removed/ extinguished.

If a leakage of refrigerant is found which requires brazing, all of the refrigerant shall be recovered from the system, or isolated (by means of shut off valves) in a part of the system remote from the leak. Removal of refrigerant shall be according to Clause DD.9.



Annex DD.9) Removal and evacuation

When breaking into the refrigerant circuit to make repairs – or for any other purpose – conventional procedures shall be used. However, for flammable refrigerants it is important that best practice be followed, since flammability is a consideration. The following procedure shall be adhered to:

- a) Safely remove refrigerant following local and national regulations;
- b) Purge the circuit with inert gas (optional for A2L);
- c) Evacuate (optional for A2L);
- d) Continuously flush or purge with inert gas when using flame to open circuit;
- e) Open the circuit
- f) The refrigerant charge shall be recovered into the correct recovery cylinders if venting is not allowed by local and national codes. For appliances containing flammable refrigerants, the system shall be purged with oxygen-free nitrogen to render the appliance safe for flammable refrigerants.
This process might need to be repeated several times. Compressed air or oxygen shall not be used for purging refrigerant systems.
- g) For appliances containing flammable refrigerants, refrigerants purging shall be achieved by breaking the vacuum in the system with oxygen-free nitrogen and continuing to fill until the working pressure is achieved, then venting to atmosphere, and finally pulling down to a vacuum (optional for A2L). This process shall be repeated until no refrigerant is within the system (optional for A2L). When the final oxygen-free nitrogen charge is used, the system shall be vented down to atmospheric pressure to enable work to take place.
- h) The outlet for the vacuum pump shall not be close to any potential ignition sources, and ventilation shall be available.



(Annex DD.10) Charging procedures

In addition to conventional charging procedures, the following requirements shall be followed.

- a) Ensure that contamination of different refrigerants does not occur when using charging equipment. Hoses or lines shall be as short as possible to minimize the amount of refrigerant contained in them.
- b) Cylinders shall be kept in an appropriate position according to the instructions.
Ensure that the REFRIGERATION SYSTEM is earthed prior to charging the system with refrigerant.
- c) Label the system when charging is complete (if not already).
- d) Extreme care shall be taken not to overfill the REFRIGERATION SYSTEM.
- e) Prior to recharging the system, it shall be pressure-tested with the appropriate purging gas.
- f) The system shall be leak-tested on completion of charging but prior to commissioning.
A follow up leak test shall be carried out prior to leaving the site.



(Annex DD.11) Decommissioning

Before carrying out this procedure, it is essential that the technician is completely familiar with the equipment and all its detail. It is recommended good practice that all refrigerants are recovered safely. Prior to the task being carried out, an oil and refrigerant sample shall be taken in case analysis is required prior to re-use of recovered refrigerant. It is essential that electrical power is available before the task is commenced.

- a) Become familiar with the equipment and its operation
- b) Isolate system electrically.
- c) Before attempting the procedure, ensure that:
 - mechanical handling equipment is available, if required, for handling refrigerant cylinders.
 - all personal protective equipment is available and being used correctly;
 - the recovery process is supervised at all times by a competent person;
 - recovery equipment and cylinders conform to the appropriate standards.
- d) Pump down refrigerant system, if possible.
- e) If a vacuum is not possible, make a manifold so that refrigerant can be removed from various parts of the system.
- f) Make sure that cylinder is situated on the scales before recovery takes place.
- g) Start the recovery machine and operate in accordance with instructions.
- h) Do not overfill cylinders (no more than 80% volume liquid charge).
- i) Do not exceed the maximum working pressure of the cylinder, even temporarily.
- j) When the cylinders have been filled correctly and the process completed, make sure that the cylinders and the equipment are removed from site promptly and all isolation valves on the equipment are closed off.
- k) Recovered refrigerant shall not be charged into another REFRIGERATION SYSTEM unless it has been cleaned and checked.
- l) The outlet for the vacuum pump shall not be close to any potential ignition sources and ventilation shall be available.



(Annex DD.12) Labeling

Equipment shall be labeled stating that it has been de-commissioned and emptied of refrigerant. The label shall be dated and signed. For appliances containing FLAMMABLE REFRIGERANTS, ensure that there are labels on the equipment stating the equipment contains FLAMMABLE REFRIGERANT.

**(Annex DD.13) Recovery**

When removing refrigerant from a system, either for servicing or decommissioning, it is recommended good practice that all refrigerants are removed safely.

When transferring refrigerant into cylinders, ensure that only appropriate refrigerant recovery cylinders are employed. Ensure that the correct number of cylinders for holding the total system charge is available. All cylinders to be used are designated for the recovered refrigerant and labelled for that refrigerant (i.e. special cylinders for the recovery of refrigerant). Cylinders shall be complete with pressure-relief valve and associated shut-off valves in good working order. Empty recovery cylinders are evacuated and, if possible cooled before recovery occurs.

The recovery of equipment shall be in good working order with a set of instructions concerning the equipment that is at hand and shall be suitable for the recovery of the flammable refrigerant. If in doubt, the manufacturer should be consulted. In addition, a set of calibrated weighing scales shall be available and in good working order. Hoses shall be complete with leak-free disconnect couplings and in good condition.

The recovered refrigerant shall be processed according to local legislation in the correct recovery cylinder, and the relevant waste transfer note arranged. Do not mix refrigerants in recovery units and especially not in cylinders.

If compressors or compressor oils are to be removed, ensure that they have been evacuated to an acceptable level to make certain that flammable refrigerant does not remain within the lubricant. The compressor body shall not be heated by an open flame or other ignition sources to accelerate this process. When oil is drained from a system, it shall be carried out safely.

2.3 Installation Safety

WARNING

1. Failure to observe rigging instructions may lead to equipment damage, personal injury, or death.
2. Lifting method and procedure must comply with all local and national codes and regulations.
3. The use of safety slings in addition to lifting lugs is required.
4. Do not lift the dehumidifier in high winds or above people.

CAUTION

1. Do not tip the dehumidifier on its side.
2. Avoid dropping the unit down stairways or subjecting it to severe mechanical shock.



1. Installation must be performed according to the installation instructions.
2. Installation must be performed by a licensed and trained technician. In addition, they must be knowledgeable about the safety regulations, rules for the prevention of accidents, and national / in-house regulations.
3. Only use the included accessories, parts and specified items for installation. Using non OEM parts can cause equipment failure which can lead to serious injury or death.
4. Install the equipment on top of a firm structure that can fully support its weight. If the chosen location cannot support the equipment's weight, or the installation is not done properly, the equipment may fall and cause significant property damage, severe injury, and / or death.

2.4 Service & Maintenance Safety

WARNING

1. Disconnect power before servicing.
2. The unit contains high voltage wiring and moving parts which may cause serious injury or death.
3. Failure to properly wire the dehumidifier may create the possibility of shock and can lead to premature system failure.
4. Disconnect Power to the Unit before you adjust the blower.

CAUTION

1. Condensate drain lines installed in an unconditioned space must be heat taped to prevent freezing.
2. Check the heat tape yearly before winter operation.
3. You must clean the system thoroughly to prevent repeated compressor burnouts.



Any operation concerning the installation, maintenance, repair, disassembly, and dismantling of the unit shall be carried out by qualified personnel, in accordance with Annex HH to the standard UL 60335-2-40 4th edition, who hold a valid certificate of compliance with the existing standards.

The above-mentioned operations include:

- Breaking into the refrigeration circuit;
- Opening of sealed components;
- Opening of ventilated enclosures.

Maintenance must be performed in accordance with Section 3.2 of this manual and the relevant Annexes of DD. Failure to do so can result in fire or explosion.



Danger Due to Live Hazardous Voltage

Work on electrical components and wiring may only be carried out by trained electricians or by persons instructed in electricity under the supervision of an electrician in accordance with electrical engineering regulations.



A second person must always be present when working on energized part or lines.



Disconnect Supply Mains and use Lock Out – Tag Out procedures before servicing equipment. It is generally forbidden to carry out work on electrical live parts. Failure to disconnect power and follow Lock Out-Tag Out can result in contact with Hazardous Live Voltages. This can cause serious injury and/or death.

When doors and/or covers are removed the equipment protection class becomes IP00.









Wear protective gloves. Equipment can contain contaminated refrigerant and oil which can cause severe burns.





Wear eye protection when servicing equipment containing refrigerants, which can be hazardous.

2.5 Equipment Lifecycle





2.5.1 Transport

 	<p>This Equipment contains refrigerants, oils and other harmful liquids. These liquids shall not be permitted to enter municipal wastewater or groundwater sources.</p> <p>Dispose of liquids as required by local environmental law.</p>		<p>Equipment weight exceeds unassisted lifting limits. The use of lifting equipment is mandatory any time the unit is to be moved.</p>
  	<ul style="list-style-type: none"> • Always observe weight specifications and permissible carrying loads of means of transport. • Failure to observe rigging instructions may lead to equipment damage, personal injury, or death. • Lifting method and procedure must comply with all local and national codes and regulations. • The use of safety slings in addition to lifting lugs is required. • Do not lift the equipment in high winds or above people • Never stand underneath suspended equipment because defective transport equipment could cause death. • Avoid mechanical shocks and impacts to the equipment during transport. • Avoid extreme heat or cold. • Do not stack equipment • Only handle equipment with suitable hoisting gear. • Do not tip the unit on its side. • Do not step on top of unit. 		

2.5.2 Storage

  	<p>Store equipment in its original packaging in a dry area that is protected from weather and contamination until final installation.</p> <p>Do not stack equipment.</p> <p>Avoid exposure to extreme temperatures.</p> <p>Prevent prolonged storage.</p> <p>Maintain a safe distance from open flames, as R-454B refrigerant is flammable.</p>
---	---

2.5.3 Disposal/Recycle

	<p>Wear protective gloves. Equipment can contain contaminated refrigerant and oil which can cause severe burns.</p>		<p>This Equipment contains refrigerants, oils and other harmful liquids. These liquids shall not be permitted to enter municipal wastewater or groundwater sources. Dispose of liquids as required by local environmental law.</p>
	<p>This equipment contains electronics, and other components/hazardous materials. Do not dispose as household waste or unsorted municipal waste. Dispose or recycle as required by local environmental law.</p>		<p>This Equipment contains metals and other recyclable materials which must be recycled as required by local environmental law.</p>

3. Minimum Room Size Requirements for A2L Refrigerants

	<p>Equipment contains flammable gas. Failure to comply with the Installation Requirement for Equipment using R-454B Refrigerant can lead to fire or explosion.</p>
---	--

WARNING

Equipment containing R-454B refrigerant shall be installed, operated and stored in a room with floor area larger than the area defined in the following section based on the total refrigerant charge in the system.

CAUTION

Pipe-work including piping material, pipe routing, and installation shall include protection from physical damage in operation and service and be in compliance with national and local codes and standards, such as ASHRAE 15, ASHRAE 15.2, IAPMO Uniform Mechanical Code, ICC International Mechanical Code, or CSA B52. All field joints shall be accessible for inspection prior to being covered or enclosed.

To comply with the requirements of UL 60335-2-40 the equipment, installed rooms, and conditioned rooms must meet the requirements laid out in this section. The flowcharts in the figures below can roughly be followed to determine what requirements apply. One flowchart is required for the conditioned spaces, and the other flowchart is required for the machinery room (or installed room) if applicable.

Requirements for Conditioned Spaces

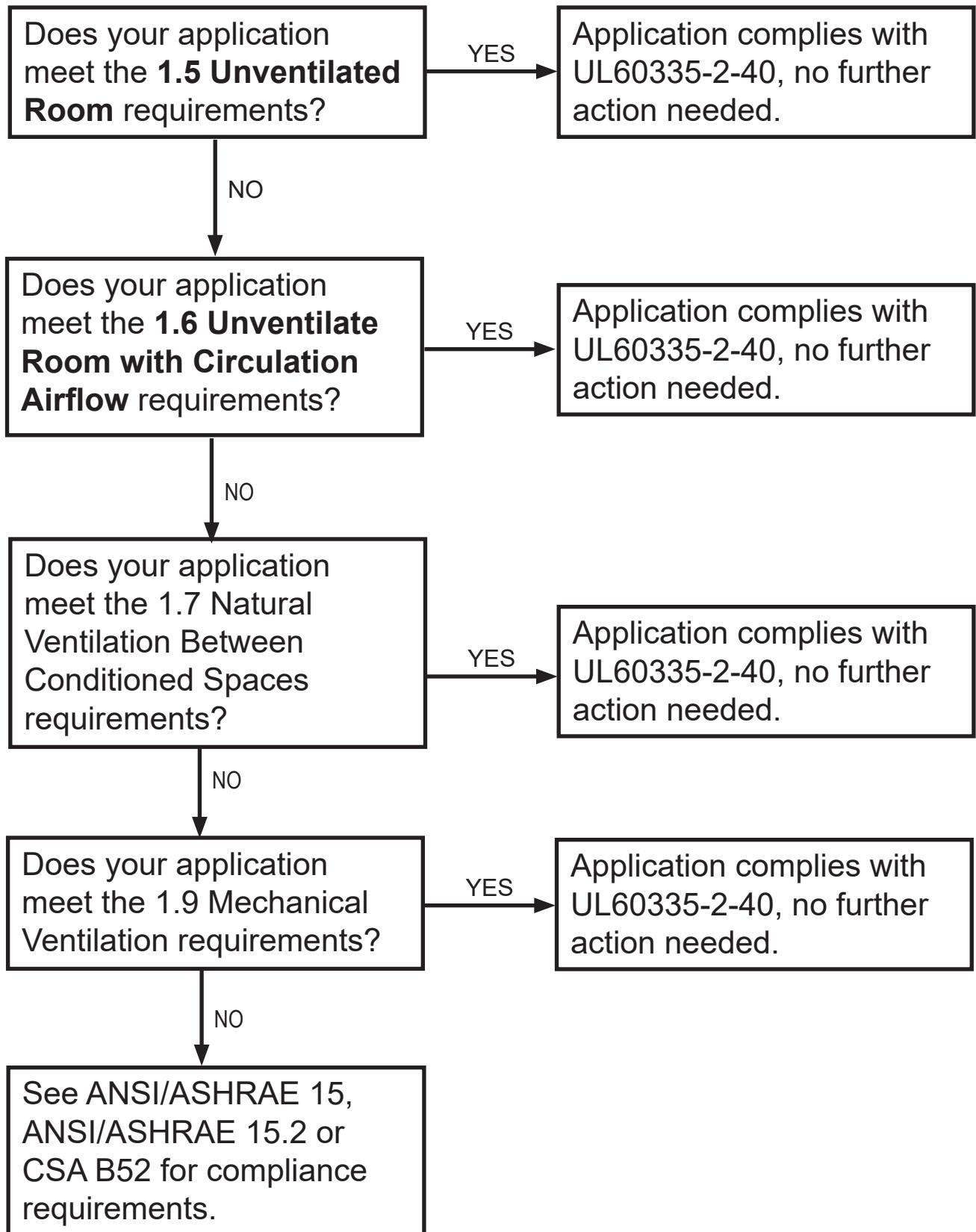

Figure 2: Flowchart for Conditioned Spaces

Requirements for Machinery Room

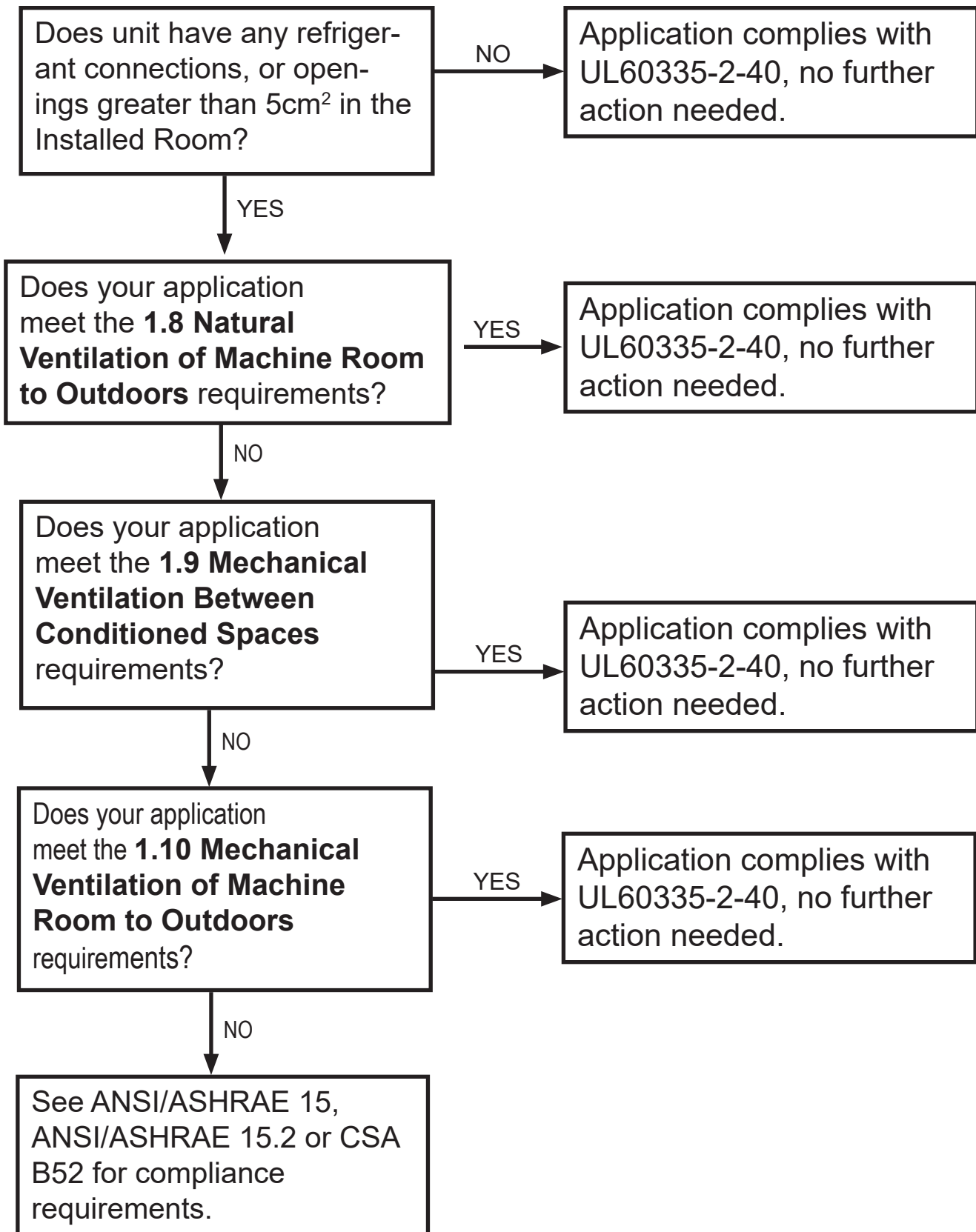

Figure 3 Flowchart for Machinery Room

3.1 Refrigerant Leak Detection and Mitigation

WARNING

This equipment comes with a factory installed Refrigerant Detection Device. To be effective the unit must be electrically powered at all times after installing, other than when servicing. The Refrigerant Detection Device is capable of determining its end-of-life.

Refrigerant sensors for refrigerant detection systems shall only be replaced with sensors specified by the appliance manufacturer.

General Maintenance for refrigerant detection sensors:

- Keep all debris from around the openings of the sensors.
- Check connections and wiring schedule basics.
- Don't try to repair sensors, only replace.

All Desert Aire equipment will be provided with A2L leak detection sensor(s) compliant with Annex LL of the UL 60335-2-40 and the location within the equipment has been tested according to Annex MM of UL 60335-2-40. The leak detector has a N.O. contact that will “close” when the sensor is powered and DOES NOT detect a high level of refrigerant. If the sensor loses power, or enters an alarm state, the contact will “open”. This contact will be used to energize/de-energize a relay with a N.O. and N.C. contact available for customer connection. The leak detection strategy will occur at the unit level, and the leak mitigation strategy can occur at either the unit level or the room level depending on the application. The leak detection strategy will occur at the unit level, and the leak mitigation strategy can occur at either the unit level or the room level depending on the application.



The A2L sensor will perform a series of self-diagnostics when first powered. If these self-diagnostics are passed the sensor will be put into normal operation state. If these self-diagnostics fail, the sensor will be put in an alarm/ fail-safe state. During normal operation the sensor health is continuously monitored, and if an error is found the sensor will be put in an alarm/ fail-safe state. Refer to the table below for sensor diagnostics.

Table 1: A2L Sensor Self Diagnostics

STATE	GREEN LED	RED LEAD	ACTION
Power-up Fail Safe	ON	ON	Recycle Power
End of Life	OFF	Blinking	Replace Sensor
Runtime Fail Safe	OFF	Blinking	Over 5min- Replace Sensor
Alarm	OFF	ON	Service Equipment
Warning	ON	Heartbeat	Schedule Service
Near End of Life	Blinking	Heartbeat	Schedule Service
Normal Operation	Heartbeat	OFF	-
Power-up	ON	OFF	Wait ~5sec

All Desert Aire equipment is provided with a blower to handle the process air during normal operation. This blower can provide circulation airflow as a leak mitigation strategy depending on the application. When the refrigerant detection system detects a leak, the following will be initiated by the unit.

- De-energize a dedicated A2L alarm relay. The Normally Open and Normally Closed dry contacts of this relay will be made available for field wiring to interface with room level mitigation systems.
- Disable compressor operation.
- The unit supply blower(s) will be commanded to run at full speed. This can be used to provide minimum circulation airflow (Q_{\min}) if applicable.
- The refrigerant detection system and controls will maintain the above action until at least 5 minutes after the refrigerant detection system has reset. Building fire and smoke systems may override these functions.



If the leak detector detects a leak, the above operations will be initiated even if the unit is in standby mode by system switch, BMS or digital input.

3.2 Determination of Room Area

The room area is defined as the area enclosed by the projection of walls, doors and partitions to the floor. Rooms on the same floor connected by an open passageway can be added to the room area so long as they meet the following criteria.

- It is a permanent opening
- It extends to the floor
- It is intended for people to walk through

When the location of the equipment is above 1969ft (600m), the Altitude Adjustment Factor in the table is needed to calculate the minimum room size.

Table 2: Room Area Adjustment Factor

Halt		AF
Meter	Feet	
0	0	1.00
200	656	1.00
400	1312	1.00
600	1969	1.00
800	2625	1.02
1000	3281	1.05
1200	3937	1.07
1400	4593	1.10
1600	5249	1.12
1800	5906	1.15
2000	6562	1.18
2200	7218	1.21
2400	7874	1.25
2600	8530	1.28
2800	9186	1.32
3000	9843	1.36
3200	10499	1.40
3400	11155	1.49
3600	11811	1.58
3800	12467	1.66

Depending on the application, the conditioned room, installed room, and rooms connected via an airduct system will need to be evaluated.

3.3 Opening Conditions for Connected Rooms and Natural Ventilation

Adjacent rooms on the same floor connected by a permanent opening can be considered a single room provided they meet the following criteria. This is also the requirement for natural ventilation between occupied spaces.

The minimum opening area for natural ventilation shall not be less than $An_{v_{min}}$. Chart GG.7 below shows the required opening per the given room area for various refrigerant charges.

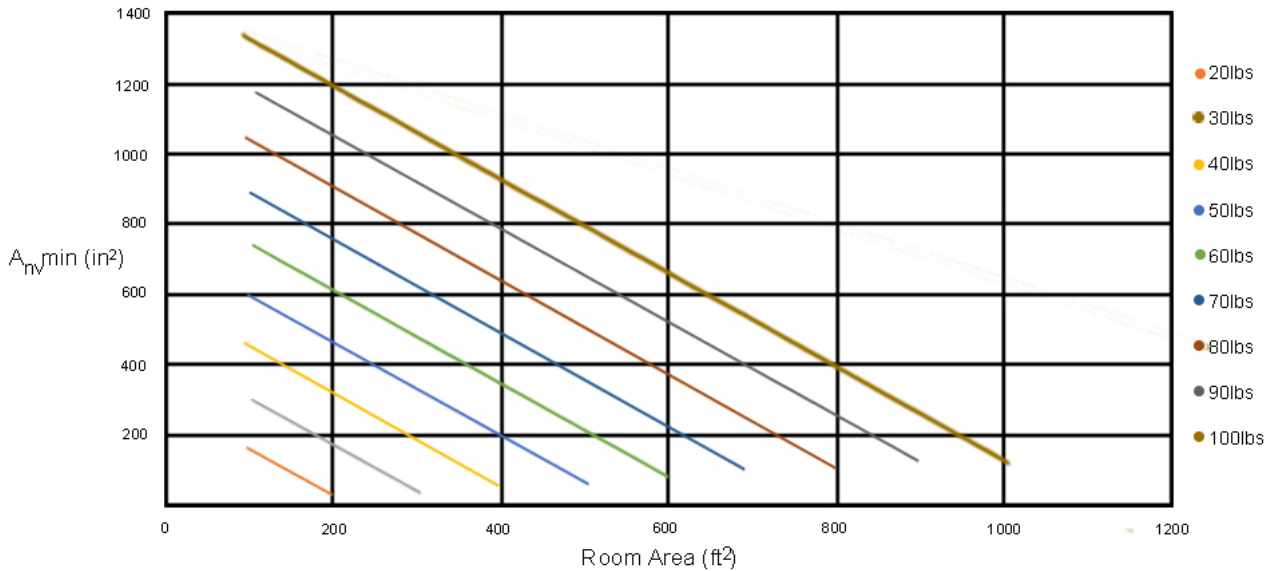

Figure 4: Chart GG.7 - Required Opening (in²) per Given Room Area (ft.²)

The opening is permanent and cannot be closed.

Any opening above 300mm cannot be counted towards minimum opening for natural ventilation ($An_{v_{min}}$) (Figure 5).

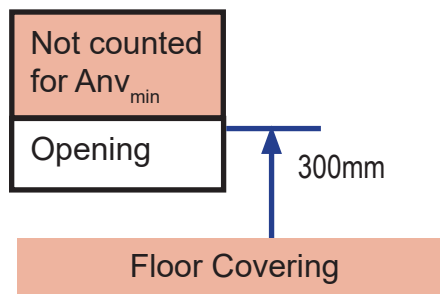

Figure 5: Openings Above 300mm and Minimum Natural Ventilation Criteria

At least 50% of Anv_{min} shall be below 200mm from the floor (Figure 6).

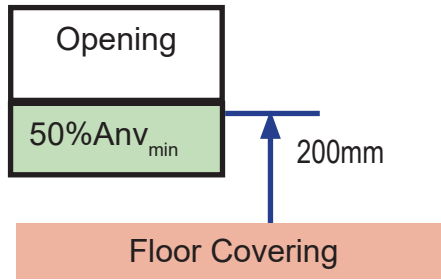

Figure 6: Minimum Natural Ventilation Opening Requirements Below 200mm

The bottom of the lowest opening shall not be higher than the point of release when the unit is installed and not more than 100mm from the floor (Figure 7).

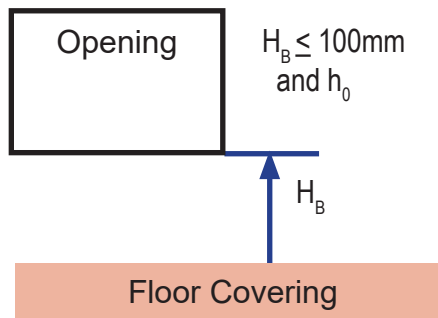

Figure 7: Height Regulations for the Lowest Opening in Installation

For openings extending to the floor the height shall not be 20mm (Figure 8)

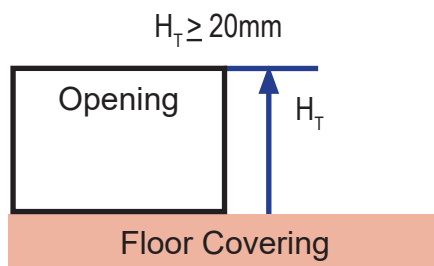

Figure 8: Minimum Height Requirement for Floor-Extending Openings

3.4 Opening Requirements for Mechanical Ventilation

When mechanical ventilation is applied the openings must meet the following requirements:

- The lower edge of openings extracting air from the room shall not be more than 100mm above the floor (see Figure 9).

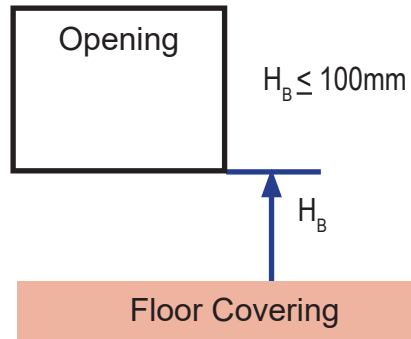
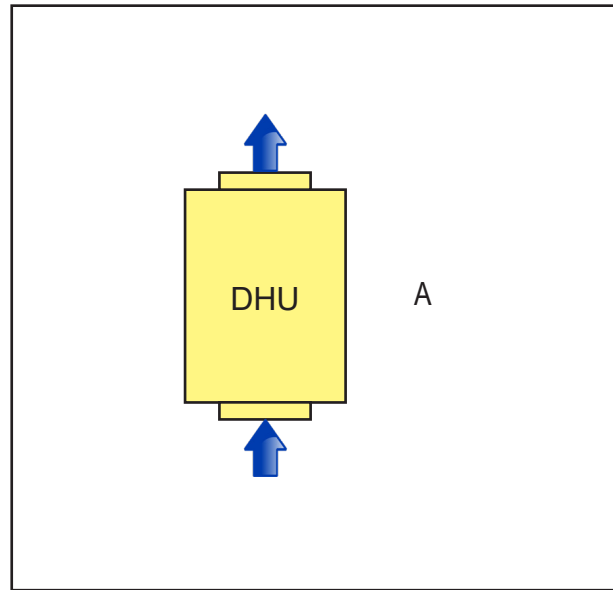

Figure 9: Opening Requirements for Mechanical Ventilation

- The openings supplying makeup air to the room shall be located such that the supplied makeup air mixes with the leaked refrigerant.
- When makeup air is supplied from the same space where ventilation air extracted from the space is discharged, ventilation air discharge openings shall be separated by a sufficient distance, but not less than 3 m, from the makeup air intake openings to prevent recirculation to the space.

3.5 Unventilated Room

For non-ducted units where the installed space is the conditioned space and the total charge is less than 15.39kg (33.93lb), determine the total charge of the system and use Table 3 to find the minimum floor area, A_{min} .



$$A_{min} \leq A$$

Figure10: Unventilated Non-Ducted Unit

Table 3: Minimum Floor Area for Unventilated Room Non-Ducted Unit

Charge			Minimum Floor Area (A_{min})	
lbs	oz	kg	ft ²	m ²
10	0	4.54	1,980.2	184.0
15	0	6.80	4,455.4	413.9
20	0	9.07	7,920.7	735.9
25	0	11.34	12,376.1	1,149.8
30	0	13.61	17,821.5	1,655.7

Note: If the area of the room is larger than A_{min} , then no further measures are required.

3.6 Unventilated Room with Circulation Airflow

The room area can be increased per Table 4 if the requirements of circulation airflow are met.

- The appliance must be connected via an air duct system to one or more rooms where the supply and return air are directly ducted to the space.
- Spaces where airflow may be limited by zoning dampers cannot be included when determining total area.
- The minimum airflow Q_{\min} from Table 4 must be achieved by the unit.

Desert Aire units typically provide continuous airflow but, in all cases, a refrigerant detection sensor(s) is provided to ensure circulation airflow is achieved if there is a refrigerant leak.

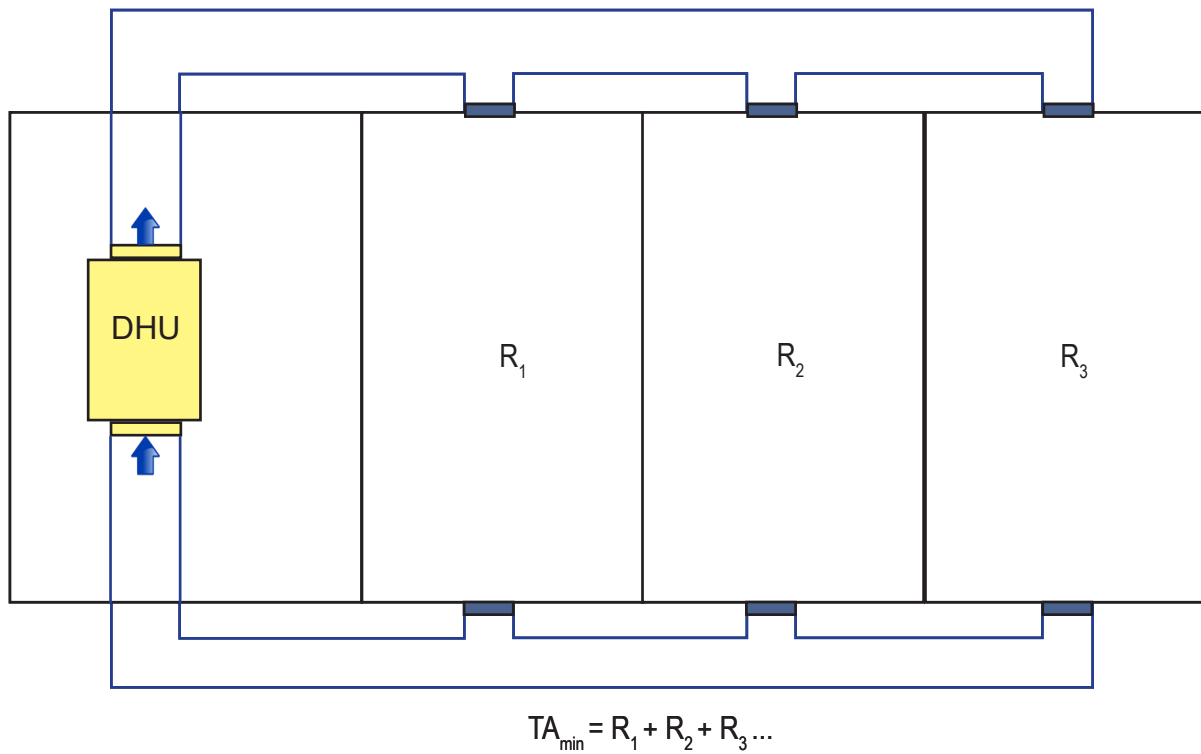

Figure 11: Air Duct Diagram for One or More Rooms.

Table 4: Minimum Area, and Airflow for Unventilated Room with Circulation Airflow

Charge			A _{min}		Q _{min}	
lbs	oz	kg	ft ²	m ²	ft ³ /min	m ³ /h
10	0	4.54	147.5	13.7	266	452
15	0	6.80	221.2	20.5	399	678
20	0	9.07	294.9	27.4	532	904
25	0	11.34	368.7	34.2	665	1130
30	0	13.61	442.4	41.1	798	1356
35	0	15.88	516.1	47.9	931	1582
40	0	18.14	589.8	54.8	1064	1808
45	0	20.41	663.6	61.6	1197	2034
50	0	22.68	737.3	68.5	1330	2260
55	0	24.95	811.0	75.3	1464	2486
60	0	27.22	884.8	82.2	1597	2713
65	0	29.48	958.5	89.0	1730	2939
70	0	31.75	1,032.2	95.9	1863	3165
75	0	34.02	1,106.0	102.7	1996	3391
80	0	36.29	1,179.7	109.6	2129	3617
85	0	38.56	1,253.4	116.4	2262	3843
90	0	40.82	1,327.1	123.3	2395	4069
95	0	43.09	1,400.9	130.1	2528	4295
100	0	45.36	1,474.6	137.0	2661	4521
105	0	47.63	1,548.3	143.8	2794	4747
110	0	49.90	1,622.1	150.7	2927	4973
115	0	52.16	1,695.8	157.5	3060	5199
120	0	54.43	1,769.5	164.4	3193	5425
125	0	56.70	1,843.3	171.2	3326	5651
130	0	58.97	1,917.0	178.1	3459	5877
135	0	61.23	1,990.7	184.9	3592	6103
140	0	63.50	2,064.5	191.8	3725	6329
145	0	65.77	2,138.2	198.6	3858	6555
150	0	68.04	2,211.9	205.5	3991	6781
155	0	70.31	2,285.6	212.3	4125	7007
160	0	72.57	2,359.4	219.2	4258	7233
165	0	74.84	2,433.1	226.0	4391	7459
170	0	77.11	2,506.8	232.9	4524	7685

3.7 Natural Ventilation Between Conditioned Spaces

If natural ventilation is applied between conditioned (occupied) spaces the following requirements must be met.

- Natural ventilation from an occupied space cannot be made to the outdoors.
- The openings must comply with the requirements described in section 3.3 **Opening Conditions for Connected Rooms and Natural Ventilation.**
- For ducted equipment use Table 4 to determine A_{min} . The area of the conditioned space plus the area of the ventilation room must be larger than A_{min} .
- For non-ducted equipment use Table 3 to determine A_{min} . The area of the conditioned space plus the area of the ventilation room must be larger than A_{min} . The area of the installed room must be at least 20% of A_{min} .

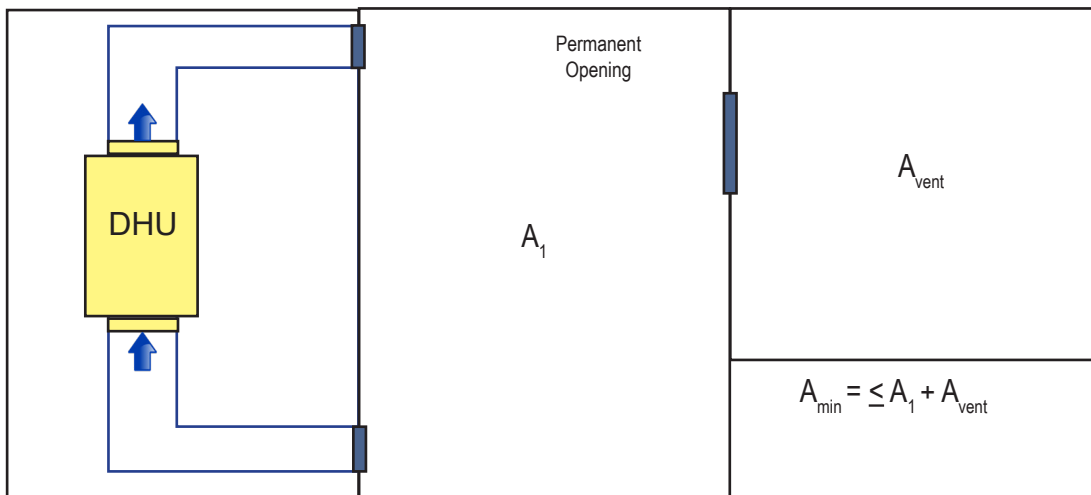

Figure 12: Ducted unit with Natural Ventilation

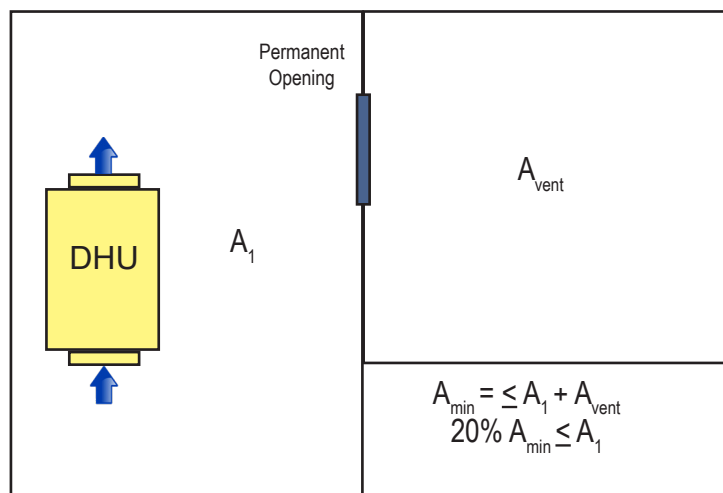

Figure 13: Non-Ducted unit with Natural Ventilation

3.8 Natural Ventilation of Machine Room to Outdoors

If natural ventilation of a Machinery Room (Unoccupied space) to the outdoors is applied the following requirements must be met.

- Natural ventilation to the outdoors is not allowed below ground level.
- Natural ventilation from occupied spaces shall not be made to the outdoors.
- The openings must comply with the requirements described in section **3.3 Opening Conditions for Connected Rooms and Natural Ventilation**, but the minimum opening area will be calculated differently as described below.
- The minimum opening area Anv_{min} shall be determined by Table 5. See the figure below for more details.

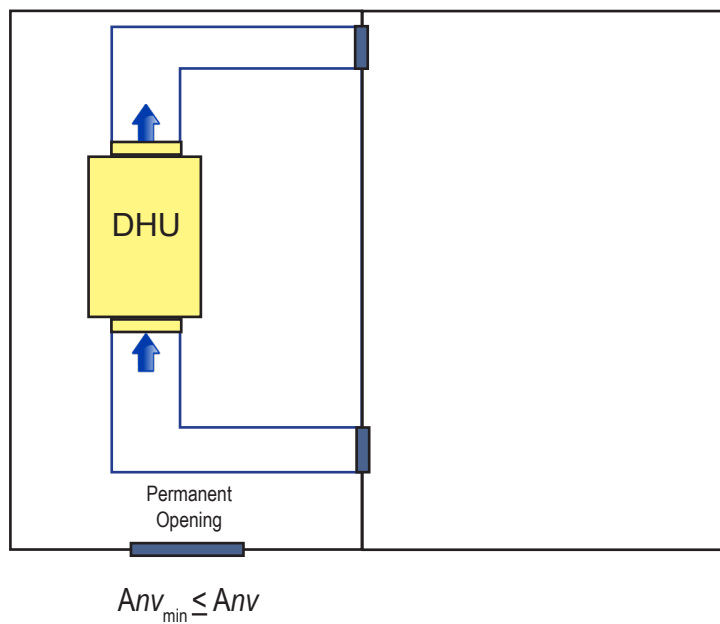

Figure 14: Natural Ventilation of Machinery Room to the Outdoors

Table 5: Minimum Opening Area for Natural Ventilation of Machinery Room to the Outdoors

Charge			Minimum Floor Area (A_{min})	
lbs	oz	kg	ft ²	m ²
10	0	4.54	0.5	0.042
15	0	6.80	0.7	0.063
20	0	9.07	0.9	0.084
25	0	11.34	1.1	0.105
30	0	13.61	1.4	0.127
35	0	15.88	1.6	0.148
40	0	18.14	1.8	0.169
45	0	20.41	2.0	0.190
50	0	22.68	2.3	0.211
55	0	24.95	2.5	0.232
60	0	27.22	2.7	0.253
65	0	29.48	3.0	0.274
70	0	31.75	3.2	0.295
75	0	34.02	3.4	0.316
80	0	36.29	3.6	0.338
85	0	38.56	3.9	0.359
90	0	40.82	4.1	0.380
95	0	43.09	4.3	0.401
100	0	45.36	4.5	0.422
105	0	47.63	4.8	0.443
110	0	49.90	5.0	0.464
115	0	52.16	5.2	0.485
120	0	54.43	5.5	0.506
125	0	56.70	5.7	0.527
130	0	58.97	5.9	0.549
135	0	61.23	6.1	0.570
140	0	63.50	6.4	0.591
145	0	65.77	6.6	0.612
150	0	68.04	6.8	0.633
155	0	70.31	7.0	0.654
160	0	72.57	7.3	0.675
165	0	74.84	7.5	0.696
170	0	77.11	7.7	0.717

Note: If the area of the room is larger than A_{min} , then no further measures are required.

3.9 Mechanical Ventilation Between Conditioned Spaces

Desert Aire units will be equipped with a refrigerant detection sensor(s) and have the following controls provided. The following controls will be active for at least 5 minutes after the refrigerant detection sensor has reset.

- Close an alarm contact provided for the customer to indicate refrigerant leak.
- Compressor operation will be disabled.
- If mechanical ventilation between conditioned spaces is required (Figures ,15,16 Illustrates Ducted, Non-Ducted, and Mechanical Ventilation respectively), refer to Table 4 to determine Q_{\min} and EA_{\min} for the application.

The following requirements must be met.

- The Desert Aire provided alarm contact will need to be integrated into a room level mitigation system that will provide minimum airflow Q_{\min} .
- The area of the ventilation room must be greater than or equal to the EA_{\min} .
- The openings must meet the **Opening Requirements for Mechanical Ventilation** (see Figure 9 above).

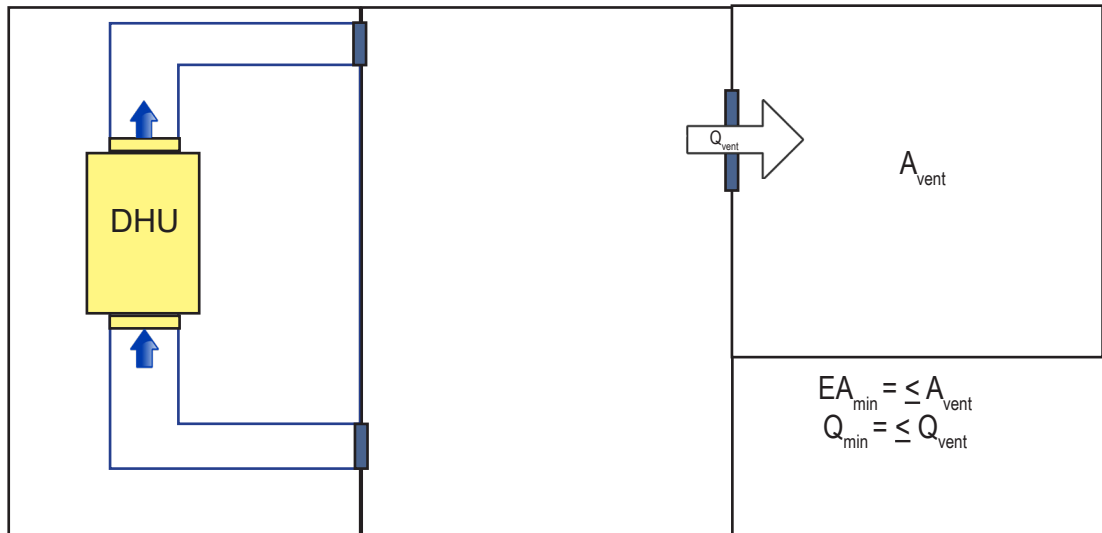

Figure 15: Ducted Unit with Mechanical Ventilation Between Conditioned Spaces

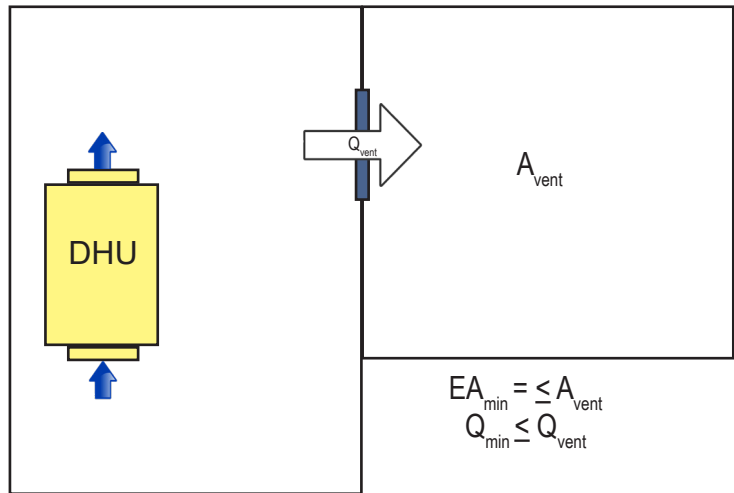

Figure 16: Non-Ducted Unit with Mechanical Ventilation Between Conditioned Spaces

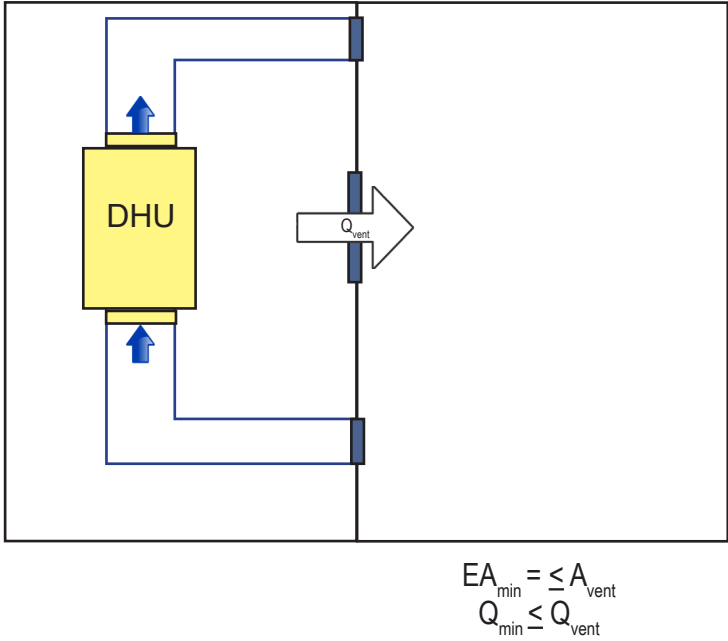

Figure 17: Mechanical Ventilation to Conditioned Spaces from Mechanical Room

Table 6: Minimum Entering Area and Minimum Airflow for Mechanical Ventilation Between Conditioned Space and Mechanical Ventilation of Machine Room to the Outdoors

Charge			EA _{min}		Q _{min}	
lbs	oz	kg	ft ²	m ²	ft ³ /min	m ³ /h
10	0	4.54	0.0	0.0	240.8	409.1
15	0	6.80	0.0	0.0	401.0	681.3
20	0	9.07	0.0	0.0	561.2	953.5
25	0	11.34	0.0	0.0	721.4	1225.6
30	0	13.61	0.0	0.0	881.6	1497.8
35	0	15.88	29.5	2.7	1041.7	1769.9
40	0	18.14	103.2	9.6	1201.9	2042.1
45	0	20.41	177.0	16.4	1362.1	2314.2
50	0	22.68	250.7	23.3	1522.3	2586.4
55	0	24.95	324.4	30.1	1682.5	2858.5
60	0	27.22	398.1	37.0	1842.7	3130.7
65	0	29.48	471.9	43.8	2002.8	3402.9
70	0	31.75	545.6	50.7	2163.0	3675.0
75	0	34.02	619.3	57.5	2323.2	3947.2
80	0	36.29	693.1	64.4	2483.4	4219.3
85	0	38.56	766.8	71.2	2643.6	4491.5
90	0	40.82	840.5	78.1	2803.8	4763.6
95	0	43.09	914.3	84.9	2964.0	5035.8
100	0	45.36	988.0	91.8	3124.1	5307.9
105	0	47.63	1061.7	98.6	3284.3	5580.1
110	0	49.90	1135.4	105.5	3444.5	5852.3
115	0	52.16	1209.2	112.3	3604.7	6124.4
120	0	54.43	1282.9	119.2	3764.9	6396.6
125	0	56.70	1356.6	126.0	3925.1	6668.7
130	0	58.97	1430.4	132.9	4085.2	6940.9
135	0	61.23	1504.1	139.7	4245.4	7213.0
140	0	63.50	1577.8	146.6	4405.6	7485.2
145	0	65.77	1651.6	153.4	4565.8	7757.3
150	0	68.04	1725.3	160.3	4726.0	8029.5
155	0	70.31	1799.0	167.1	4886.2	8301.7
160	0	72.57	1872.8	174.0	5046.4	8573.8
165	0	74.84	1946.5	180.8	5206.5	8846.0
170	0	77.11	2020.2	187.7	5366.7	9118.1

3.10 Mechanical Ventilation of Machine Room to Outdoors

Desert Aire units will be equipped with a refrigerant detection sensor(s) and have the following controls provided. The following controls will be active for at least 5 minutes after the refrigerant detection sensor has reset.

- Close an alarm contact provided for the customer to indicate refrigerant leak.
- Compressor operation will be disabled.
- If mechanical ventilation to the outdoors is required (Figure 18), use Table 6 to determine Q_{min} for the application.

The following requirements must be met.

- The Desert Aire provided alarm contact will need to be integrated into a room level mitigation system that will provide minimum airflow Q_{min} .
- The openings must meet the **Opening Requirements for Mechanical Ventilation** (see Figure 9 above).

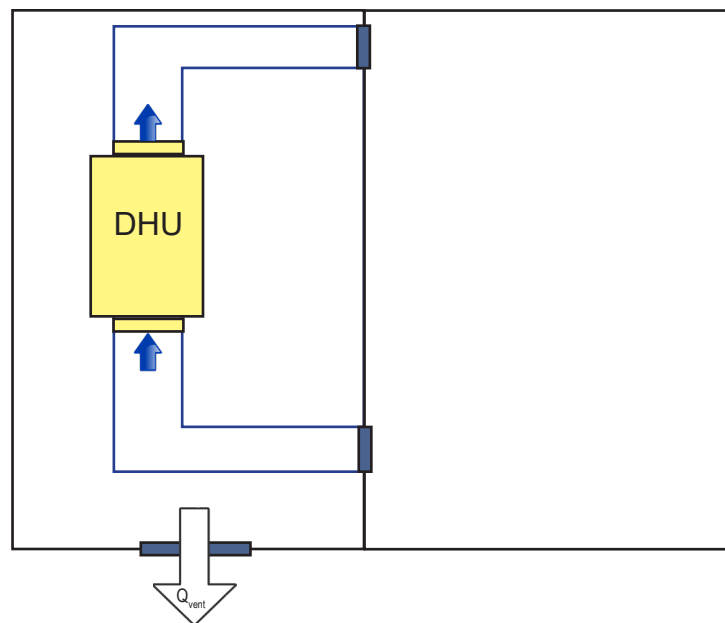

Figure 18: Mechanical Ventilation of Machinery Room to Outdoors

4 Introduction

The equipment must be installed, operated, and serviced/maintained in accordance with this manual and national and local codes. Only authorized and knowledgeable personnel may access the unit, and they must be qualified as specified by Annex HH of UL 60335-2-40 4th edition. Desert Aire is not liable for any personal harm, or material damage arising from failure to comply with this manual and national or local codes.



4.1 Inspection

Desert Aire inspects and tests each dehumidifier before it leaves the factory so that you receive a quality piece of equipment. Unfortunately, equipment may become damaged in transit. Inspect the dehumidifier carefully before signing the receiving papers. Check for both visible and concealed damage. Remove crating and inspect the exterior cabinet for damage. Dented panels, broken crating or any fluids leaking from the unit should be documented upon delivery.

4.2 Freight Damage Claims

If the dehumidifier has been damaged, document the extent of the damage. Take pictures. Next, obtain a claim form from the carrier. Promptly fill out and return the form. Carriers may deny claims that you have not filled out within a week of delivery. Notify Desert Aire of any damage.

4.3 Rigging

	<ul style="list-style-type: none">• Failure to observe rigging instructions may lead to equipment damage, personal injury and/or death.
	<ul style="list-style-type: none">• Lifting methods and procedures must comply with all local and national codes and regulations.• The use of safety slings in addition to lifting lugs is required.• Do not lift the dehumidifier in high winds or above people.
	<ul style="list-style-type: none">• See Equipment Safety Installation section for warnings and hazards associated with rigging equipment.

Desert Aire dehumidifiers are solidly built and can be very heavy. Avoid personal injury and damaging the equipment by planning the installation carefully. Use moving equipment whenever possible.

4.4 Rigging of Dehumidifier

Depending upon the unit type, various rigging methods are used to best lift the equipment. Personnel should avoid stepping on the top of the unit. Desert Aire dehumidifiers are not designed to support the weight of a person on all portions of the roof. Damage incurred through caved or distorted top panels will not be covered under warranty.

- Packaged dehumidifiers are equipped with four or more lifting points. Use spreader bars and safety straps when you rig the equipment.
- Utilize all of the lifting lugs provided when hoisting the unit.
- Test-lift the dehumidifier to verify that it is properly balanced.
- Refer to diagram below for additional lifting instructions.

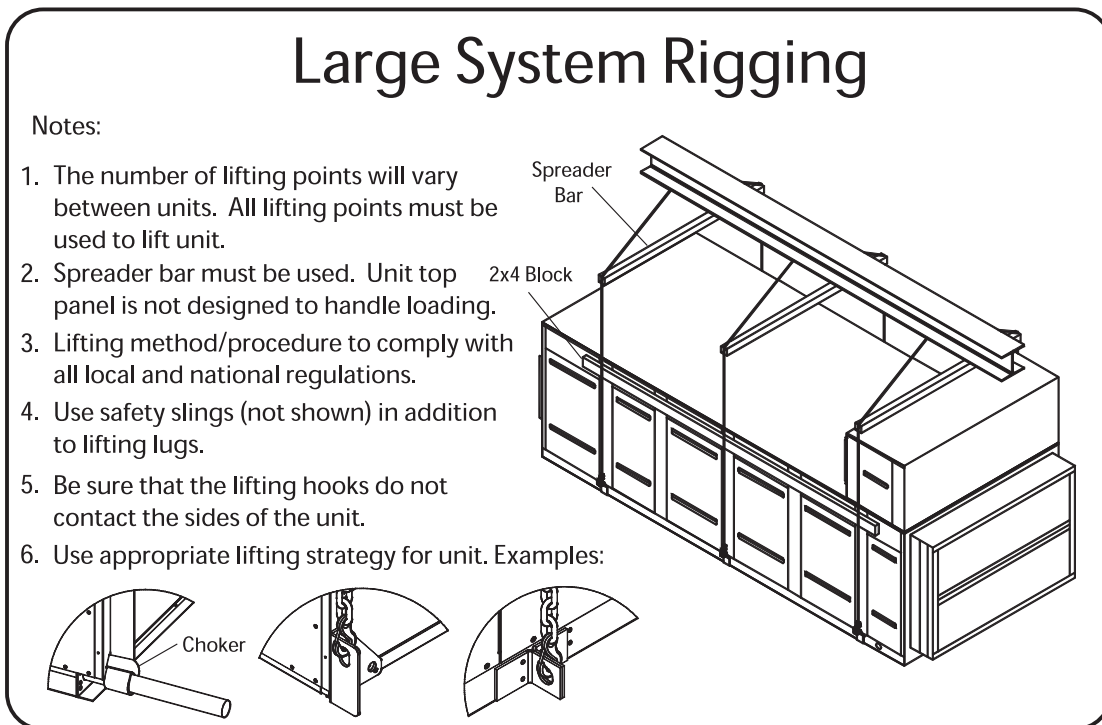

! CAUTION

1. Do not tip the dehumidifier on its side.
2. Avoid dropping the unit down stairways or subjecting it to severe mechanical shock

4.4.1 Rigging the Remote Condenser

The optional remote condensers are equipped with four or more lifting eyes. Test-lift the remote condenser to verify that it is properly balanced.

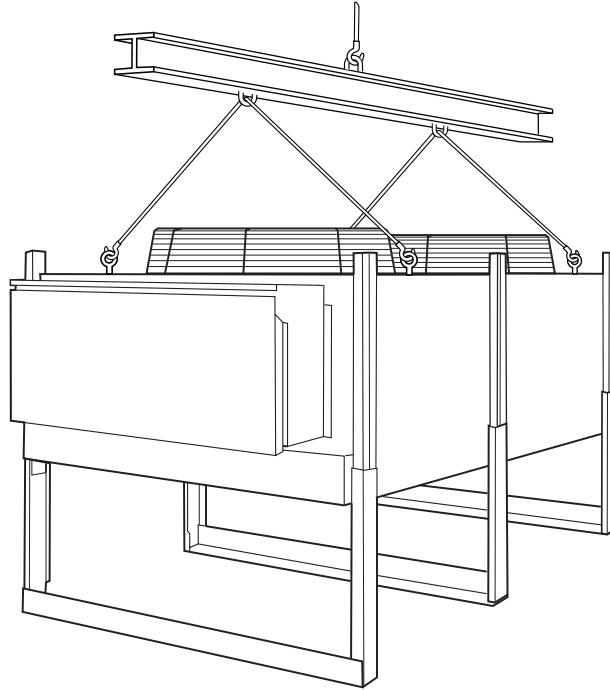

Figure 20: Typical Rigging for an Optional Remote Condenser

CAUTION

1. Do not lift the remote condenser by its refrigeration headers or return bends

4.5 Operating Range

Table 7: Operating Range for Refrigerant Pressure, Altitude, Water Pressure and Temperature

	Glycol Percent	LC/LV	
		Water Cooled	Pool/ Spa
Maximum allowable refrigerant pressure (psig)		650 psig (4481 kPa)	650 psig (4481 kPa)
Maximum altitude		12000 ft (3657 m)	12000 ft (3657 m)
Maximum operating water pressure		225 psig (1551 kPa)	225 psig (1551 kPa)
Minimum operating water pressure		0 PSIG (0 kPa)	0 PSIG (0 kPa)
Maximum operating water temperature		105°F (40°C)	105°F (40°C)
Minimum operating water temperature (°F)	0	40°F (4.5°C)	45°F (7.3°C)
	5	37°F (2.8°C)	
	10	34°F (1.2°C)	
	15	31°F (-0.5°C)	
	20	27°F (-2.7°C)	
	25 and higher	25°F (3.8°C)	

4.5.1 Unit Conversion

US Customary

$$^{\circ}\text{F} = (^{\circ}\text{C} + 9/5) + 32$$

$$\text{psig} = 6.8945 * \text{kPa}$$

$$\text{In.WC} = \text{kPa} / 4.0416$$

$$\text{CFM} = 0.02832 * (\text{m}^3/\text{min})$$

International System of Units (SI)

$$^{\circ}\text{C} = (^{\circ}\text{F} - 32) * 5/9$$

$$\text{kPa} = \text{psig} / 6.8945$$

$$\text{kPa} = 4.0416 * \text{In.WC}$$

$$\text{m}^3/\text{min} = 35.31467 * (\text{CFM})$$

5 Installation

Manual applies to standard unit configurations only.

5.1 Location of Dehumidifier

Desert Aire LC dehumidifiers require both left and right side service access to the unit for service. The LV dehumidifiers require service access to the left side and end opposite the return air connection. Allow a minimum of 36 inches of clearance around the service sides of the dehumidifier for piping, electrical connections, and service access. The non-access sides of the unit should have a minimum of 12 inches of clearance. A minimum of one unit width clearance shall be maintained in all directions of outside air intake hood on outdoor units to allow for unobstructed airflow into the unit. For packaged units, ensure a minimum of one unit width of clearance is maintained to allow for proper airflow through the condensing section. If three or more walls surround the unit consult the factory for proper unit location to allow for adequate airflow through the condenser section. Consult local, state, and national electric codes for other minimum service clearances.

Install the unit on a sturdy, level mounting surface or platform that will prevent vibration and sound transmission. Never install the dehumidifier on a wooden platform without consulting the design engineer for spring isolation requirements and sound control materials. Do not install the unit near occupied rooms such as offices or guest rooms. Do not attempt to conserve installation space by fabricating restrictive ductwork with abrupt bends. You may reduce the operating efficiency and the moisture removal capacity of the dehumidifier. See section 5.2 for detailed duct installation instructions.

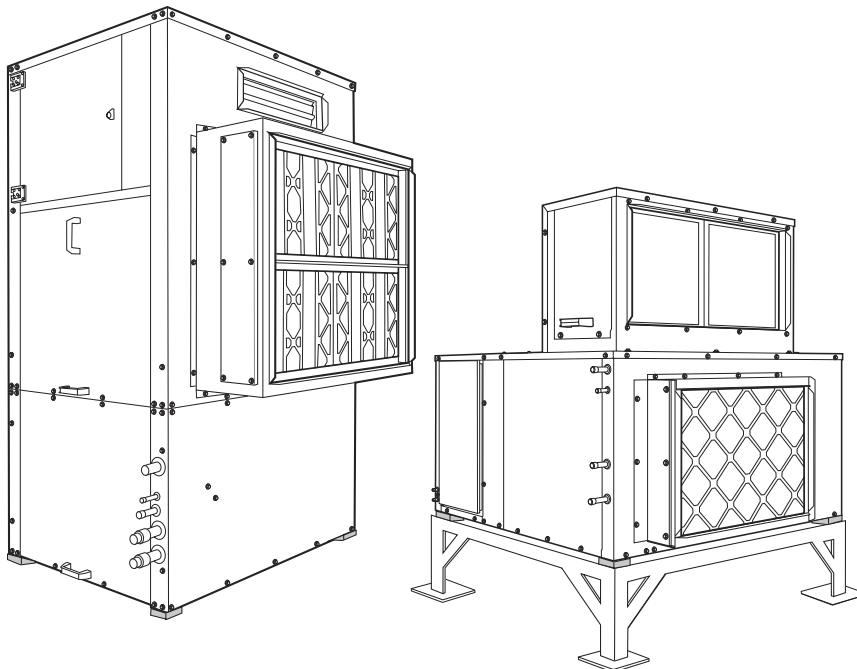

Figure 21: Typical Floor Installation

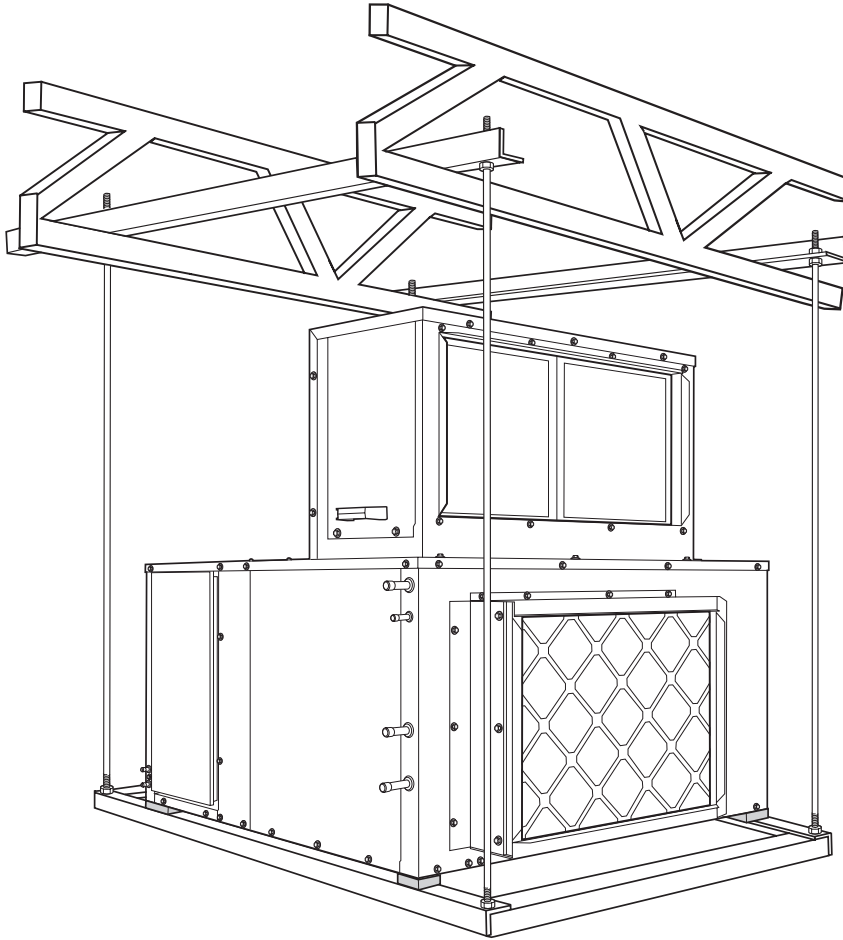

Figure 22: Typical Suspended Installation - LC Only (LV Units are Floor Units Only)

LV Only - Do not install an indoor-rated dehumidifier in an outdoor or a wet environment.

You must not install a standard dehumidifier in an unconditioned space or where ambient temperatures can fall below 45°F. If you must install the dehumidifier outside or in an unconditioned space, such as an attic, you must use an outdoor-rated dehumidifier. Desert Aire equips outdoor-rated dehumidifiers with weatherproofing and thicker insulation. You can determine whether your dehumidifier is outdoor rated by inspecting the unit rating plate. See section 8.6 for details.

5.2 Duct Installation

Duct design and installation should conform to the latest ASHRAE and SMACNA low velocity duct standards. See section 5.2 for details. Undersized restrictive ductwork with abrupt turns or transitions can decrease the efficiency and the moisture removal capacity of your dehumidifier and may lead to unit failure. Size the ductwork for an acceptable air pressure drop at the airflow volume of your dehumidifier. Use neoprene flex connectors when you attach ductwork to the dehumidifier to prevent transmission of excess vibration and noise.

Table 8: LC and LV Series Standard Unit Airflow Specifications

Model Size	Airflow Rate (CFM) (LC Only)	Airflow Rate (CFM) (LV Only)	External Static Pressure (ESP) digit 9 for LC non-packaged (A, B, C, K, L, M); digit 10 for LV (A, D)	External Static Pressure (ESP) digit 9 for LC non-packaged (D, E, F, N, P, R); digit 10 for LV (B, F)	External Static Pressure (ESP) digit 9 for LC non-packaged (G, H, J, S, T, U); digit 10 for LV (C, G)
01 (LC Only)	540	-	0.5" WC	1.0" WC	1.5" WC
02 (LC Only)	950	-			
03	1400	1400			
04	1900	2100			
05	2300	3000			
06	3000	3400			
08	3500	3800			
10 (LC Only)	4100	-			
12 (LC Only)	5500	-			
15 (LC Only)	8000	-			

Select the grilles, registers and diffusers for low static pressure loss, required throw distance, and the specified CFM rating. You can find this information in most grille manufacturer's catalogs. If you are installing the grilles in a corrosive environment, choose components made from anodized aluminum.

If you must install ductwork in an unconditioned area, use fiberglass duct wrap with vapor barrier facing. You must install the outdoor air intake away from all sources of airborne contamination such as exhaust fans or plumbing vents. You can use galvanized sheet metal ducts for most applications. However, you should use aluminum or stainless steel ducts for extreme applications such as chemical-laden environments

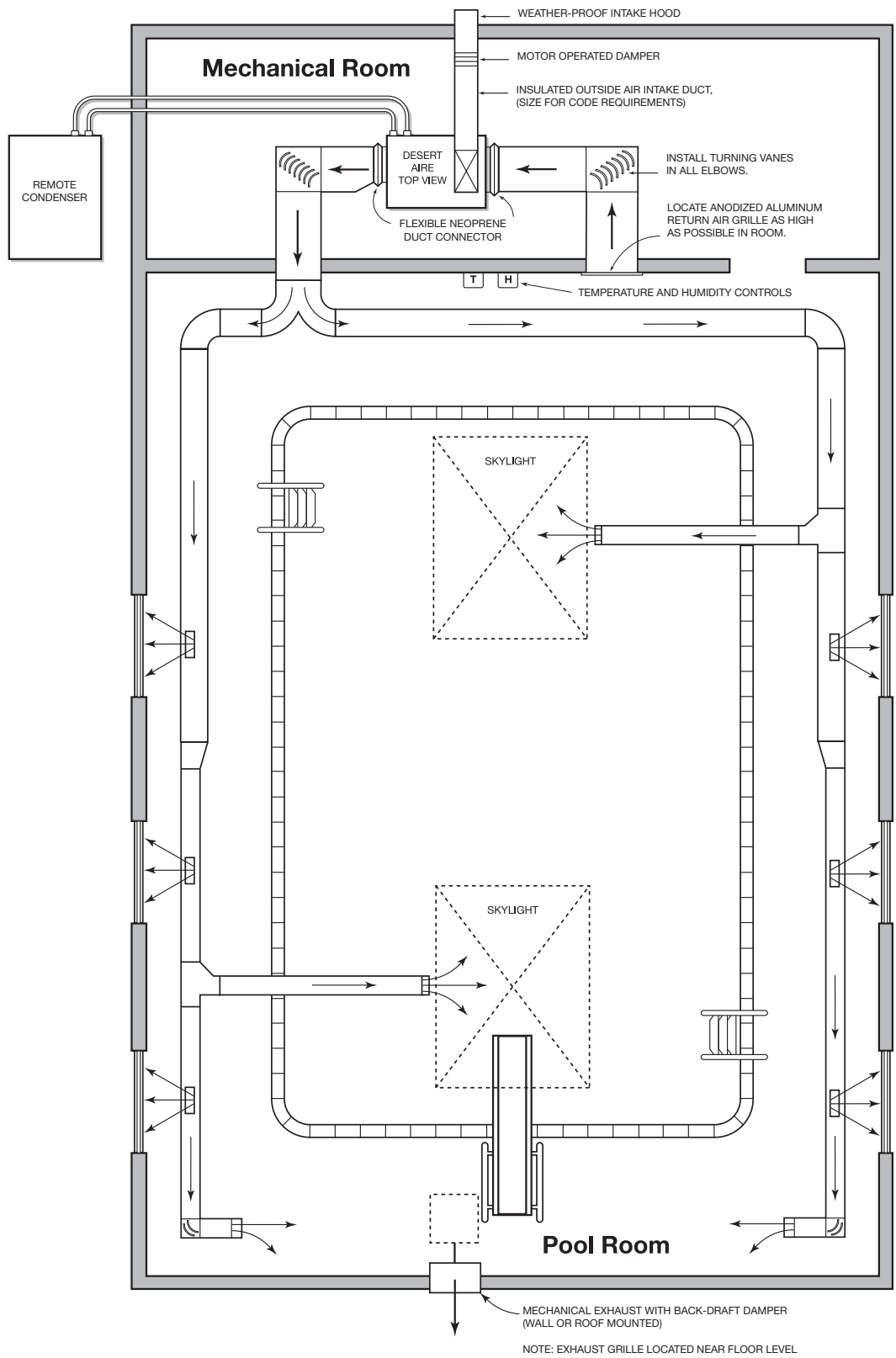

Figure 23: Basic Pool Room Layout

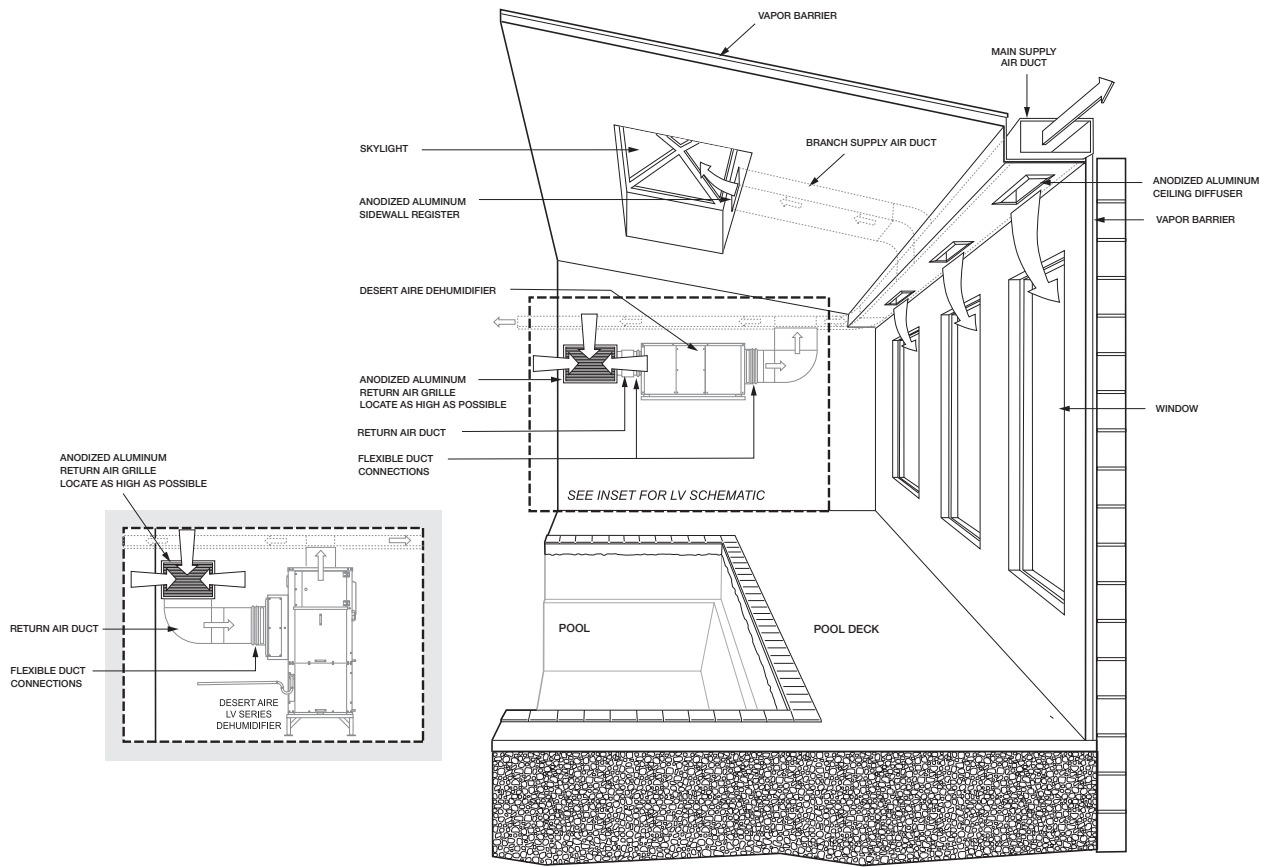

Figure 24: Soffit Duct Layout

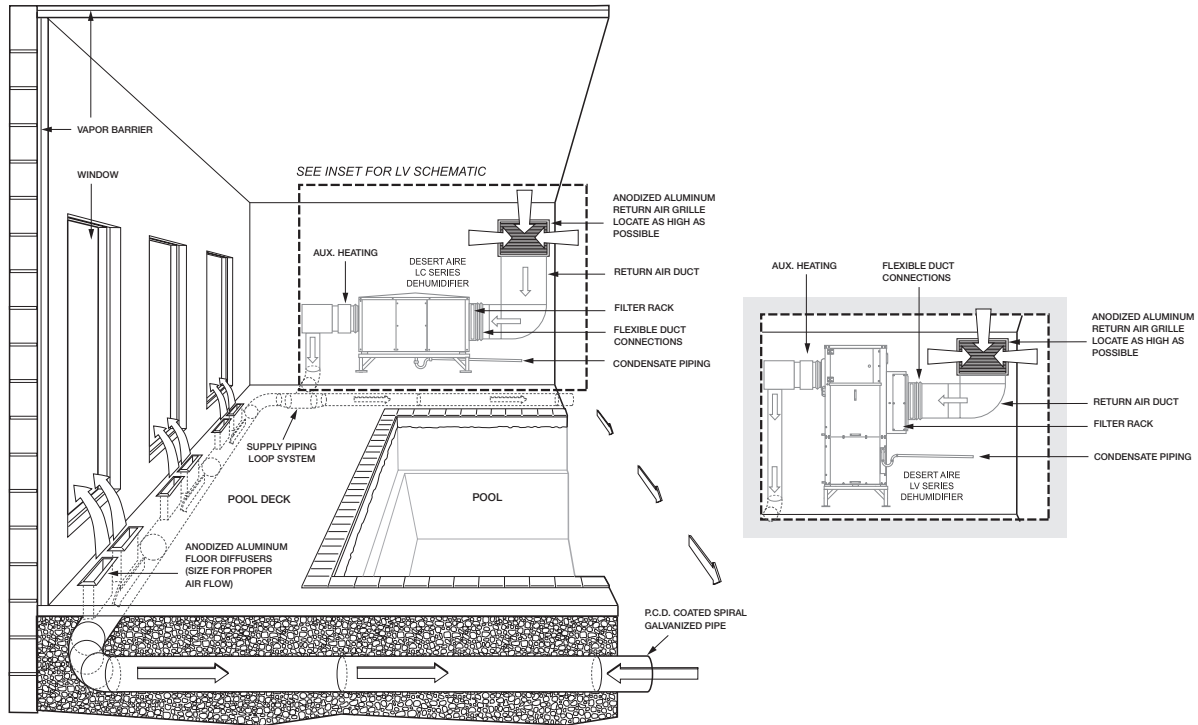

Figure 25: Under-Floor Duct Layout

5.3 Condensate Drain Piping

⚠ CAUTION

Condensate drain lines installed in an unconditioned space must be heat taped to prevent freezing. Check the heat tape yearly before winter operation.

The condensate drain connection may be on the side or the bottom of the dehumidifier, depending on the size and style of cabinet used. Use concrete blocks or steel dunnage to raise the dehumidifier high enough above the floor to provide clearance for the field-supplied condensate drain trap.

Note: Dehumidifiers with gas heating option may have condensate form inside the furnace heat exchanger since it is located downstream from the cooling coil.

Note: While the supply blower runs, the drain pan area inside the dehumidifier operates at a negative pressure. Your unit requires a P-trap in the condensate drain pipe to prevent condensate from being drawn into the cabinet of the dehumidifier.

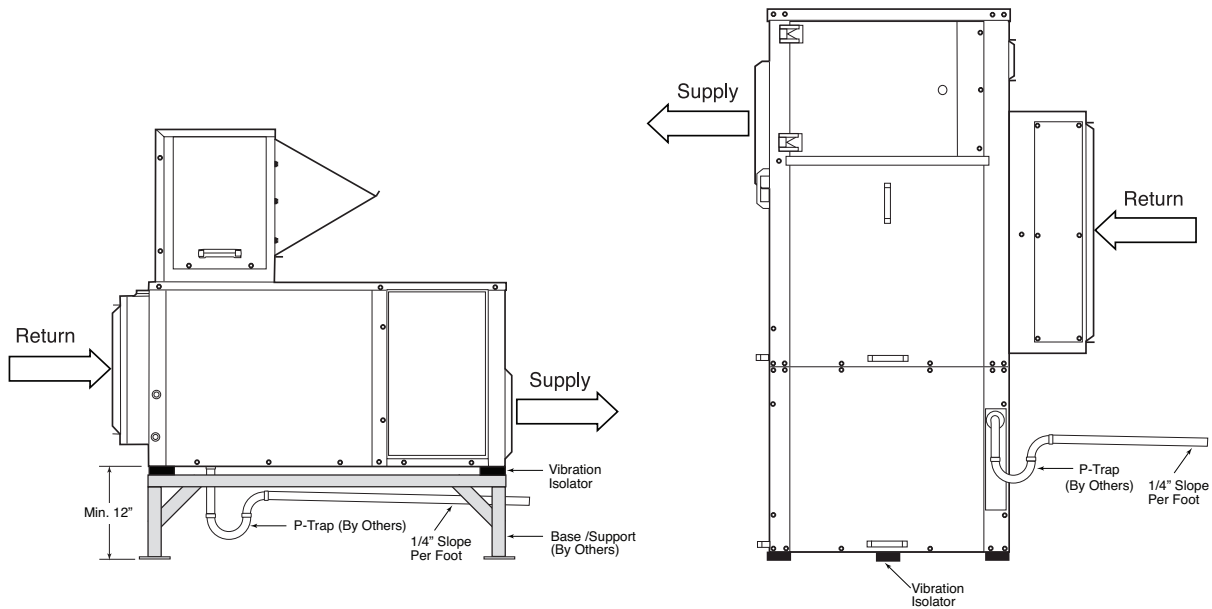

Figure 26: Condensate Piping

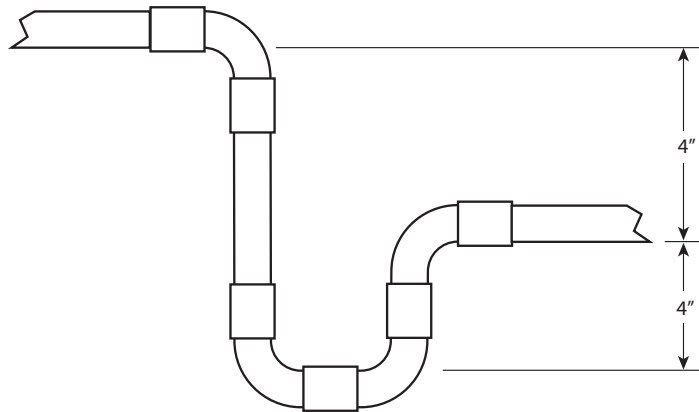

Figure 27: Sectional View of Condensate Trap Requirements

Trap the condensate as shown in Figure 26. The P-trap dimensions in Figure 27 are sized for a maximum return air static of 2.0" of water. If your return air static exceeds this specification, consult Desert Aire for help in resizing the P-trap.

You may also need to install a cleanout tee or plug near the trap. Note that the drain opening in the drain pan is off-center to simplify its cleaning and servicing. Once you have designed and installed the trap, follow this sequence:

- Connect the trap to a main drain line with 1/4" of downward pitch per linear foot of run.
- Support the drain pipe every five feet to prevent sagging.
- After you install the drain piping, prime the trap by pouring water into the drain pan of the dehumidifier.

5.4 Water Heating Applications

5.4.1 Water Piping Connections

Desert Aire LC and LV Series dehumidifiers equipped with pool water heating condensers must be connected to pool water filtration lines to operate as intended. The dehumidifier water supply circuit must tap into the main pool water line downstream from the main filter. If the main pool circulating pump is large enough, you can use a manual throttling valve to divert a portion of the water to the dehumidifier. Normally, you must size and install an auxiliary water pump which can handle the unit's required water flow rate, which is listed in Table 9. If you are using a water source other than a pool or a spa (such as a chilled water loop), the required flow rate has been printed on a label affixed near the water line stubs of the dehumidifier.

Table 9: Standard Unit Water Flow Rates for LC and LV Units

Model Size	Water Flow Rate and Pressure Drop Pool Application	Water Flow Rate and Pressure Drop Spa Application	Water Flow Rate and Pressure Drop Partial Pool/Spa Application
01 (LC Only)	2 GPM @ 5.5 ft W.C.	3 GPM @ 10.6 ft W.C.	1 GPM @ 1.8 ft W.C.
02 (LC Only)	4 GPM @ 6.9 ft W.C.	5 GPM @ 9.9 ft W.C.	1 GPM @ 1.8 ft W.C.
03	6 GPM @ 5.3 ft W.C.	8 GPM @ 8.5 ft W.C.	2 GPM @ 2.3 ft W.C.
04	8 GPM @ 6.1 ft W.C.	11 GPM @ 9.1 ft W.C.	2 GPM @ 2.3 ft W.C.
05	10 GPM @ 5.7 ft W.C.	13 GPM @ 8.3 ft W.C.	5 GPM @ 3.9 ft W.C.
06	12 GPM @ 9.2 ft W.C.	16 GPM @ 14.8 ft W.C.	5 GPM @ 3.9 ft W.C.
08	16 GPM @ 9.0 ft W.C.	18 GPM @ 10.8 ft W.C.	9 GPM @ 4.8 ft W.C.
10 (LC Only)	20 GPM @ 5.7 ft W.C.	26 GPM @ 8.3 ft W.C.	9 GPM @ 4.8 ft W.C.
12 (LC Only)	24 GPM @ 7.4 ft W.C.	31 GPM @ 9.7 ft W.C.	10 GPM @ 6.9 ft W.C.
15 (LC Only)	30 GPM @ 5.7 ft W.C.	39 GPM @ 8.3 ft W.C.	14 GPM @ 7.2 ft W.C.

A typical water circuit arrangement is shown in Figure 28. To simplify the commissioning and servicing of this job, you should install a flow meter and isolation valves in the pool water lines which feed the dehumidifier.

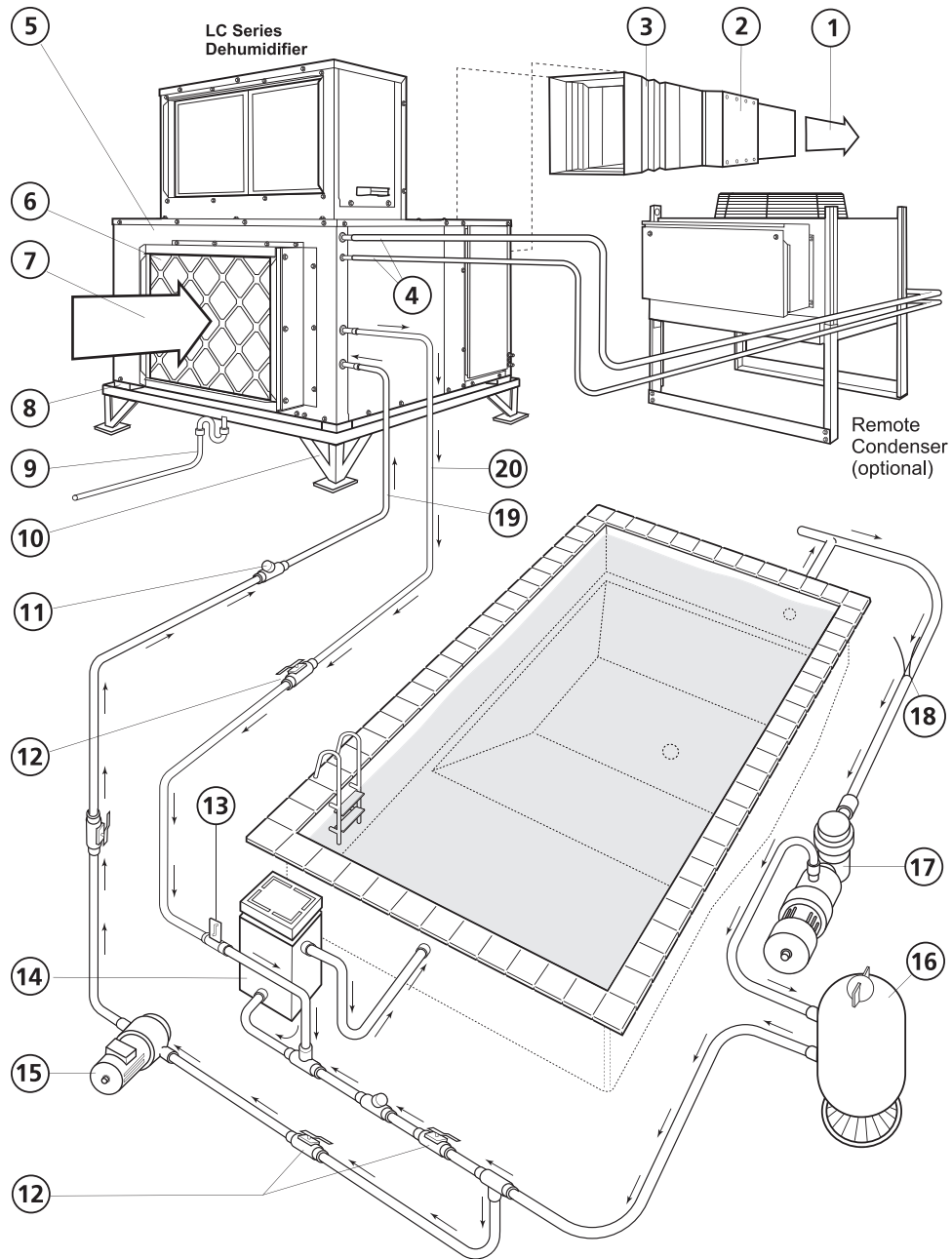

LEGEND

1	Supply Air
2	Duct Heater (Gas, Electric, Etc.)
3	Flex Duct Connector
4	Piping to Remote Condenser
5	Desert Aire LC Dehumidifier
6	Filter Rack Assembly with Filters
7	Return Air
8	Vibration Isolators
9	P-Trap
10	Base (If Required)

11	Check Valve
12	Ball Valve
13	Flow Meter
14	Main Pool Heater
15	Auxiliary Pump
16	Filter Assembly
17	Main Pool Pump
18	Water Temp Sensor (Dry Well)
19	Water Inlet
20	Water Outlet

Figure 28: Proper Pool Water Heating Installation for Desert Aire LC and LV Dehumidifiers

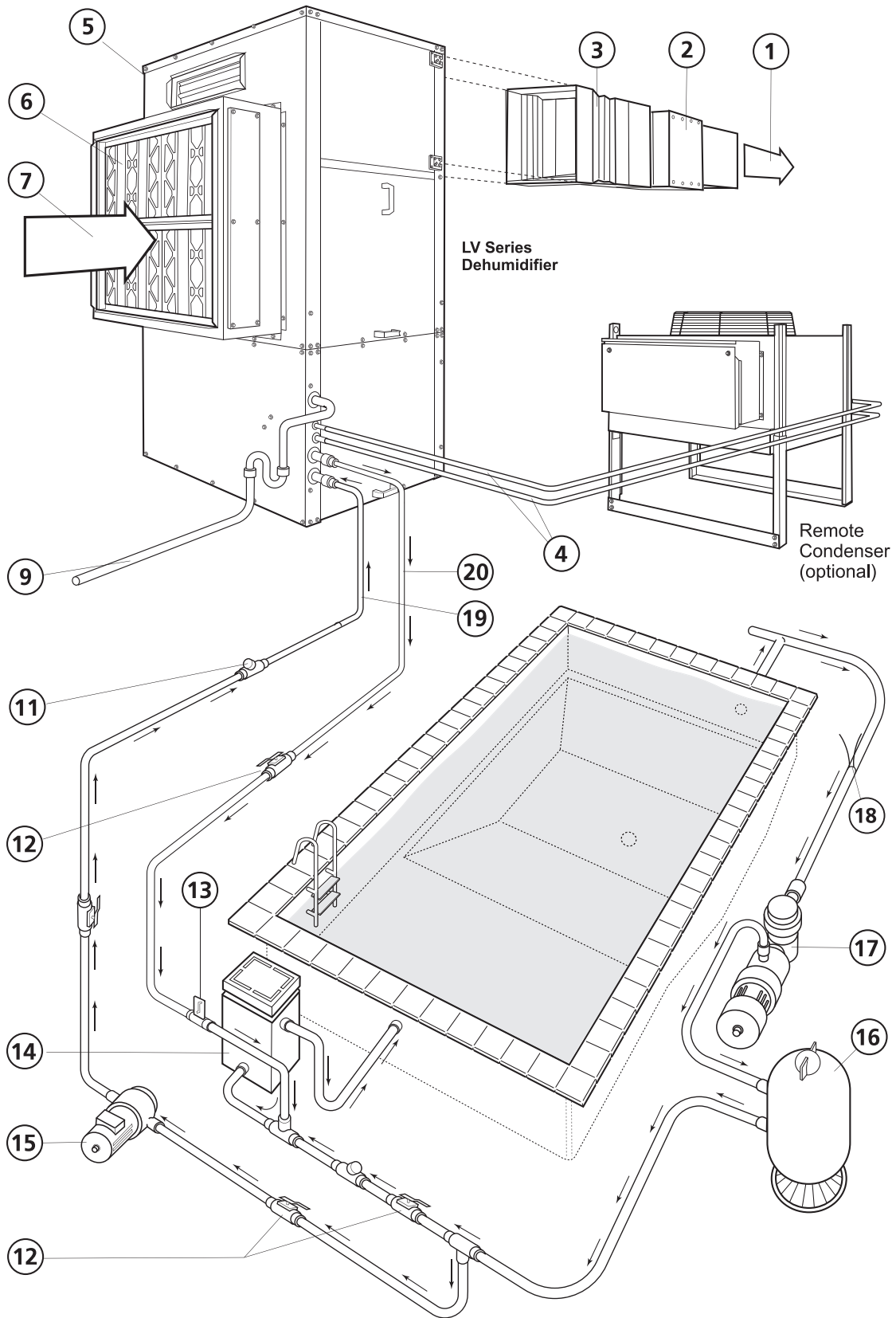

Figure 29: Proper Pool Water Heating Installation for Desert Aire LV Dehumidifiers

5.5 Remote Condenser (Optional)

Important: Refer to the separate **Air-Cooled Condensers Installation and Operation Manual** for additional details on line design, traps, clamping, and other condenser installation requirements.

LC and LV dehumidifiers installed with remote condensers may require additional oil and refrigerant charge at the time of field installation. For reference, the factory charge of the dehumidifier is shown in Table 10. Additional field installed charge is shown for each unit size, allowable line length, and remote condenser for standard units are shown in Tables 11 and 12. Note that custom systems or non-standard line configurations may have been specified. Refer to the submittal documentation or label adjacent to the remote condenser connections to confirm the charge and lines for those systems.

5.6 Unit Factory Refrigerant Charge (Lbs.)

Table 10: Unit Factory Charge

Unit Size	R-454B Refrigerant (Lbs.)
01	8
02	13
03	15
04	18
05	20
06	24
08	24
10	41
12	41
15	65

Standard RCD Series Remote Condenser Line Sizes and Additional Charge

Table 11: Standard RCD Series Remote Condenser Line Sizes and Additional Charge

	Line Length (ft.)	Line Diameter (In. OD)		R-454B Charge (lbs.)	
		Discharge Line	Liquid Line		
LC01				RCDAXXXNX-03108XXPA	
	0 < 25	1/2	1/2	5.5	
	26 < 50	1/2	1/2	7.1	
	51 < 75	1/2	1/2	8.6	
	76 < 100	5/8	1/2	10.6	
LC02				RCDAXXXNX-03108XXPA	RCDAXXXNX-07208XXPA
	0 < 25	1/2	1/2	5.5	8.4
	26 < 50	5/8	1/2	7.3	10.2
	51 < 75	5/8	1/2	8.9	11.8
	76 < 100	5/8	1/2	10.6	13.5
LC03 LV03				RCDAXXXNX-07208XXPA	RCDAXXXNX-18414XXPA
	0 < 25	5/8	1/2	8.6	13.5
	26 < 50	3/4	1/2	10.3	15.1
	51 < 75	3/4	1/2	12.3	17.2
	76 < 100	3/4	1/2	14.1	N/A
LC04 LV04				RCDAXXXNX-18414XXPA	
	0 < 25	5/8	1/2	13.6	
	26 < 50	3/4	1/2	15.5	
	51 < 75	3/4	1/2	17.3	
	76 < 100	7/8	5/8	N/A	
LC05 LV05				RCDAXXXNX-18414XXPA	
	0 < 25	3/4	1/2	13.8	
	26 < 50	3/4	1/2	15.5	
	51 < 75	7/8	5/8	20.3	
	76 < 100	7/8	5/8	23	
LC06 LV06				RCDAXXXNX-18414XXPA	
	0 < 25	3/4	1/2	13.8	
	26 < 50	7/8	5/8	17.5	
	51 < 75	7/8	5/8	20.3	
	76 < 100	1-1/8	5/8	24.5	
LC08 LV08				RCDAXXXNX-18414XXPA	
	0 < 25	3/4	1/2	13.8	
	26 < 50	7/8	5/8	17.5	
	51 < 75	7/8	5/8	20.3	
	76 < 100	1-1/8	5/8	24.5	

Table 12: Standard RCD Series Remote Condenser Line Sizes and Additional Charge

	Line Length (ft.)	Line Diameter (In. OD)		R-454B Charge (lbs.)	
		Discharge Line	Liquid Line		
LC010				RCDAXXXNX-18414XXPA	RCDBXXXNX-30414XXPA
	0 < 25	7/8	5/8	14.8	25.4
	26 < 50	7/8	5/8	17.5	28.2
	51 < 75	1-1/8	3/4	24.7	35.5
	76 < 100	1-1/8	3/4	28.9	39.7
LC12				RCDAXXXNX-18414XXPA	RCDBXXXNX-30414XXPA
	0 < 25	7/8	5/8	14.8	25.4
	26 < 50	1-1/8	5/8	18.3	29.1
	51 < 75	1-1/8	3/4	24.7	35.5
	76 < 100	1-1/8	3/4	28.9	39.7
LV15				RCDBXXXNX-30414XXPA	
	0 < 25	7/8	5/8	25.8	
	26 < 50	1-1/8	3/4	31.5	
	51 < 75	1-1/8	3/4	35.7	
	76 < 100	1-3/8	7/8	47.0	

5.7 High Voltage Wiring

CAUTION

1. Disconnect power before servicing. The unit contains high voltage wiring and moving parts which may cause serious injury or death.
2. Failure to properly wire the dehumidifier may create the possibility of shock and can lead to premature system failure.

Electrical wiring must comply with all national, state, and local codes. Refer to the wiring diagram located inside the electrical section for all wiring connections. To connect main power, attach the supply wires to the three-pole power block for three phase or two-pole power block for single phase units mounted on the electrical panel. Test the phasing of the three phase unit by “bumping” the blower contactor. Verify that the blower rotates in the proper direction. If it rotates the wrong direction, switch any two of the three wires at the power block. For a single phase unit the motors must be re-wired according to the wiring diagrams included with the motor.

To assist in compliance with NEC and local codes, a second lug connected to the service panel in equipment with pool water condensers is provided. This lug is intended to be connected to the pool equipotential bonding grid in the field when required by code. This also removes the possibility of differences in potential between metals in the pool water and the water condenser that may accelerate corrosion. The bonding lug should be connected to the equipotential grid with 8 AWG or larger solid copper conductor.

5.7.1 High Voltage Connections

On single phase units the power supply must have 3 connections (2 power and 1 ground). On three phase units the power supply must have 4 connections (3 power and 1 ground). Connect the power supply wires to the main power block located in the upper section of the electrical compartment.

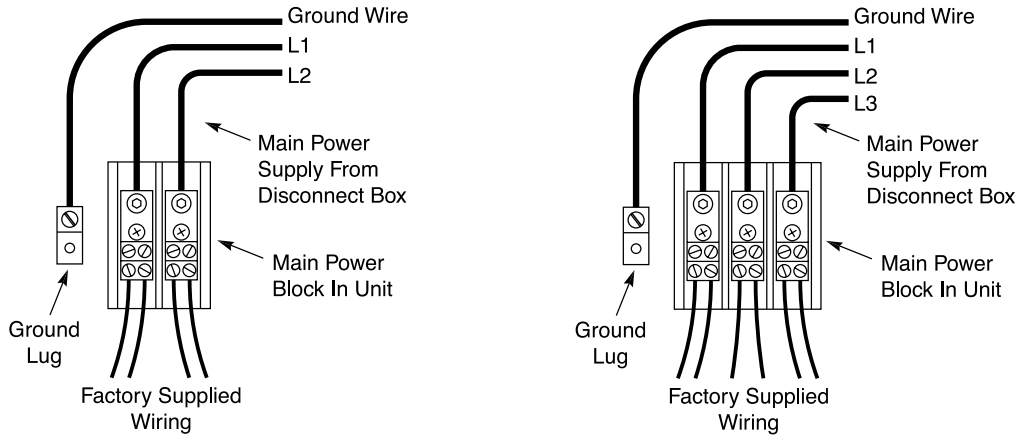

Figure 30: Single-Phase and Three-Phase System Power Connection

5.7.2 Wire and Fuse Sizing

The field-installed power supply wires and over-current protection devices must be sized to handle the minimum amperage of the dehumidifier without exceeding the maximum fuse size rating. Both the minimum ampacity and the maximum fuse size are printed on the unit rating plate.

5.8 Controls and Sensors

The standard Desert Aire LC and LV Series dehumidifiers are controlled by the CM3530 microprocessor controller. This controller is designed for precise monitoring and control of air temperature and relative humidity (RH) within a conditioned environment. The microprocessor has the option for a wall mount sensor or an optional factory mounted return air sensor. A separate controls manual has been provided. Refer to this separate manual for controller and sensor specifications, operation, and options.

5.8.1 Wall Mount Sensor

If your dehumidifier was ordered with a wall-mount humidity and temperature sensor, mount the sensor about five feet above the pool deck on an interior wall with natural air circulation. Avoid the following locations:

- Hot spots near concealed heating pipes, warm air ducts, supply register outlets, or solar radiation.
- Cold spots due to a cold wall or drafts from stairwells, doors, windows, or supply register outlets.
- Dead spots such as behind doors or in corners where room air cannot circulate freely.

5.8.2 Return Air Sensor

The return air sensor is normally used in applications where continuous blower operation is desired. A return air sensor helps ensure consistent conditions throughout the space. A drawback to this sensor is that it relies on a continuous stream of air moving past it. Using a return air sensor with a non-continuous blower may lead to short-cycling of the refrigeration compressor or loss of T/RH control in the space.

5.9 Auxiliary Heating Control Wiring

Note: You must use the Desert Aire control system to control or interlock with the room heating system. This prevents wide fluctuations in room air temperature. It also prevents the heater from trying to heat the room while the dehumidifier is running in cooling.

5.9.1 Auxiliary Heating – Dry Contact Closure

Desert Aire provides a dry contact closure to interlock with the building heating system. This contact closure is normally used to interlock with a gas or electric duct heater which has its own power supply transformer. When the room air temperature drops below the set point, the dry contact will close to energize the auxiliary heater. See the dehumidifier wiring diagram for details.

5.9.2 Auxiliary Heating – Proportional Signal

Desert Aire provides a proportional signal to modulate a heating coil control valve on units equipped with an integral heating coil.

This signal is reverse acting or direct acting depending on the settings in the controller. It is critical that units with hot water or steam coils be set properly for freeze protection. See controller manual for details on the settings and outputs.

Most proportional valves have either three or four terminals for field-installed wiring.

- Four-terminal valves have two terminals for 24 VAC power and two terminals for the signal input.
- Three-terminal valves have one terminal for the “hot” 24 VAC input, a second terminal for the “positive” signal input, and a third, common terminal for the “neutral” 24 VAC input and the “negative” signal input.

You must follow the instructions included from the valve manufacturer. Observe the proper polarity, or you may damage both the valve and the Desert Aire controller. See the unit wiring schematic for information on signal wire connection points.

5.10 Smoke Alarm Interlock

Desert Aire LC/LV dehumidifiers are equipped with a set of terminal blocks for interlocking with a smoke alarm (alarm provided and installed by others). The contacts must break when smoke is present. This will shut off the blower and compressors. See the dehumidification wiring diagram for connection details.

5.11 Gas Heater (Optional)

Several optional gas heater sizes and configurations are available to provide for heating of the outdoor air during cold conditions. Several sizes, heat exchanger designs, and combinations of capacities are available in natural gas or liquid propane fuel. Additionally, custom configurations can be specified. Installation instructions below are guidelines for installation. Refer to the separate gas heat instruction manual for additional instructions.

5.11.1 Gas Heater Installation

The Desert Aire dehumidifier may be equipped with an optional Category III gas-fired heater to provide air heating during the winter months. You must read and understand the following guidelines and warnings before you connect the heating section. Failure to follow these guidelines can result in improper and unsafe operation of this equipment, which can cause severe personal injury, death, or substantial property damage.

Observe the following precautions:

- Follow all appropriate national and local codes and guidelines when installing gas-heating equipment. Failure to follow CGA, NFPA, and/or ANSI standards may cause equipment damage, personal injury, or death.
- Corrosive environments may reduce heater service life. This furnace is not to be used for temporary heating of buildings or structure under construction. Many of the chemicals used during construction form acid-bearing condensate when burned. This can substantially reduce the life of the heat exchanger.
- Gas heating equipment located indoors requires adequate combustion air. If you install the equipment inside a penthouse or mechanical room, an indoor unit heater and terminal kit must be used.
- Connect this furnace to an approved vent system only. Combustion products must be vented outdoors.
- Use a soap-bubble solution or an electronic detector to check for gas leaks. Never use a lighter or open flame to find leaks.
- The return air duct of the furnace must be sealed air tight to prevent starvation of the combustion air, especially if the furnace is located in a closet or confined area.
- Because of the potential of odorant fade, a gas leak may not be detected by smell. If this equipment is installed below grade, contact your gas supplier for a gas detector.
- Maximum gross stack temperature must not exceed 480°F (249°C) under any circumstances.
- Care must be taken not to wet electronic components during leak test. Wetting the electronic components may damage circuitry and cause a hazardous situation. Dry moisture from all leads and terminals if minor wetting occurs. Wait at least 24 hours for the circuit to fully dry before energizing the burner circuit.
- The gas burner and its individual gas shutoff valve must be disconnected from the gas supply during pressure testing of the gas supply system at pressures in excess of 0.5 psig (14.0" wc).
- Copper and brass tubing and fittings (except tin lined) shall not be used if the gas contains more than a trace (0.3 grains per 100 cubic ft.) of hydrogen sulfide gas. Check with your gas supplier.
- For initial start-up of the furnace after installation, it may be necessary to purge the air out of the gas line. This should be done by a qualified heating contractor. If excessive gas escapes when purging the gas supply at the union, allow the area to ventilate for at least 15 minutes before attempting to start the furnace. LP gas is especially dangerous because it is heavier than air and may accumulate to a dangerous concentration at the floor level.

5.11.2 Gas Piping

Gas supply piping installation should conform with good practice and to national and local codes. The orifice for the burners are sized for either natural gas (having a heating value of 1025 BTU per cubic foot and a specific gravity of 0.60) or for liquefied propane gas (with a heating value of 2500 BTU per cubic foot and a specific gravity of 1.53). If the gas at the installation does not meet this specification, consult the factory for proper orificing.

Seal the opening for the gas supply pipe with the grommet provided.

Gas piping must be large enough to provide adequate gas with minimal pressure drop. Use the table below as a guide to capacity. Packaged units have a single gas heat connection. Ensure that any branch connection is also properly sized for a minimal pressure drop.

Table 13: Gas Pipe Capacity in Cubic Feet per Hour

Capacity of Piping						
Cubic Feet per Hour based on 0.3" w.c. Pressure Drop						
Specific Gravity for Natural Gas - 0.6 (Natural Gas - 1000BTU/Cubic Ft.)						
Specific Gravity for Propane Gas - 1.6 (Propane Gas - 2550BTU/Cubic Ft.)						
Length of Pipe	Diameter of Piping					
	1/2"		3/4"		1"	
	Natural	Propane	Natural	Propane	Natural	Propane
20'	92	56	190	116	350	214
30'	73	45	152	93	285	174
40'	63	38	130	79	245	149
50'	56	34	115	70	215	131
60'	50	31	105	64	195	119
70'	46	28	96	59	180	110
80'	43	26	90	55	170	104
90'	40	24	84	51	160	98
100'	38	23	79	48	150	92
125'	34	21	72	44	130	79
150'	31	19	64	39	120	73
175'	28	17	59	36	110	67
200'	26	16	55	34	100	61
Length of Pipe	Diameter of Piping					
	1-1/4"		1-1/2"		2"	
	Natural	Propane	Natural	Propane	Natural	Propane
20'	730	445	1100	671	2100	1281
30'	590	360	890	543	1650	1007
40'	500	305	760	464	1450	885
50'	440	268	670	409	1270	775
60'	400	244	610	372	1105	674
70'	370	226	560	342	1050	641
80'	350	214	530	323	990	604
90'	320	195	490	299	930	567
100'	305	186	460	281	870	531
125'	275	168	410	250	780	476
150'	250	153	380	232	710	433
175'	225	137	350	214	650	397
200'	210	128	320	195	610	372
Note: When sizing supply lines, consider possibilities of future expansion and increased requirements. Refer to National Fuel Gas Code for additional information on line sizing.						

Gas connection sizes are shown in Table 13. Note that these are connection sizes only. Supply lines must be sized based on pressure drop and capacity as indicated in Table 14.

Table 14: Gas Connection Sizes

Model Size	100 - 250	300 - 400
Natural Gas	1/2"	3/4"
Propane Gas	1/2"	1/2"

Gas piping must conform to all applicable codes and standards. Follow standard gas piping practices, including:

- Pitch gas piping downward in the direction of flow so condensed moisture can drain freely.
- Install a drip leg at the lowest point in the gas line to prevent moisture and debris from clogging the gas train. The National Fuel Gas Code requires the installation of a trap with a minimum of 3" drip leg. Local codes may require a longer drip leg, typically 6".
- Install a ground joint union and manual shutoff valve in an accessible position close to the equipment.
- Ensure that the pipe and fittings are free from chips and debris. Make sure that the threads are clean and properly cut.
- Seal pipe threads with pipe dope or a suitable joint compound that is compatible with the gas you are using. Do not use Teflon tape to seal gas pipe joints.
- Support gas piping using suitable straps or hangers to avoid stressing the gas valve or manifold.
- Use a backup wrench when you tighten gas pipe and fittings.
- Piping from the natural gas meter to the furnace shall be in accordance with requirements of the local utility. Piping from the LP tank to the furnace must follow the recommendations of the gas supplier.
- A readily accessible, certified manual shut off valve with a non-displaceable rotor member should be installed within six feet of the gas equipment it serves.
- A union or flanged connection shall be provided downstream from the manual valve to permit removal of controls. Provide a 1/8" N.P.T. plugged tapping at the inlet of the gas control for connection of a test gauge to check gas supply pressure to the furnace. Unions must be a ground joint type or flanged-jointed using a gasket resistant to LP gas. Pipe dope or sealant certified to be resistant to the action of liquefied petroleum gases should be used on all threaded joints.
- A drip leg must be used on both LP and natural gas installations prior to the furnace to trap oil, condensate and other impurities which might otherwise lodge in the gas valve or plug the burner orifice. When there is excessive condensation between the gas meter and the furnace, a drip leg shall be provided at the outlet of the gas meter. Failure to install a drip leg may void the warranty on the dehumidifier.
- High fire manifold gas pressure is regulated by the combination valve to 3.5" wc. Inlet pressure to the valve must be a minimum 5" wc or as noted on the rating plate and maximum of 14" wc for natural gas. Note: Always check the rating plate for minimum gas supply pressure. Minimum supply pressure requirements vary based on size of burner and gas control option. Most units require a minimum of 5" wc as stated above, but Sizes 350 and 400 with electronic modulation require a minimum of 6" wc natural gas supply pressure.
- LP Only: Experience has proved that the pressure drop in the gas line running from the outside propane gas tank to the gas appliances inside is the most frequent cause of equipment malfunctions. A single pressure regulator, located at the tank, will not reliably regulate the high tank pressures (up to 200 psi) down to 11" wc. Varying pressures will occur at the appliances as outside temperatures and usage demands vary. Two-stage regulation is the only effective method of controlling these variables.

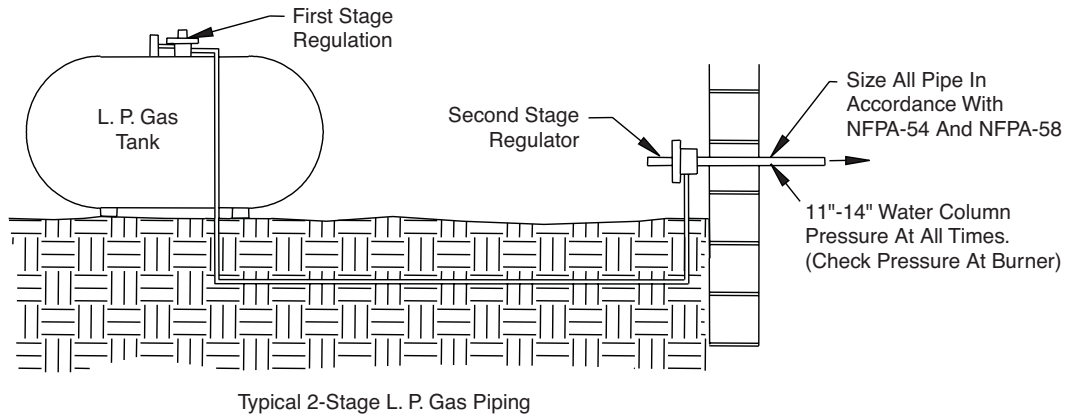

Figure 31: Typical LP Gas Piping

- **LP Only:** Use the following line size chart to size the gas piping or tubing between the LP tank and the second-stage regulator:

Table 15: LP Gas Pipe Sizing Information

Section 4					Section 5							
Use this size tubing to keep pressure drop below 2 lbs. for maximum flow shown.	If the length of line between regulators (tank to building) is this long.				Use this size tubing or pipe to keep pressure drop below 1/2" water column for maximum flow shown.	If the length of line between second-stage regulator and furnace is this long						
	Total Input load (Btu/h)	25'	50'	75'		100'	Total Input load (Btu/h)	10'	20'	30'	40'	50'
	125,000	3/8" O. D. Copper					75,000	5/8" O. D. Copper				
	250,000	3/8" O. D. Copper		1/2" O. D. Copper			125,000	5/8" O. D. Copper		3/4" Black Pipe		
	375,000	1/2" O. D. Copper					187,500	3/4" Black Pipe				
	500,000	1/2" O. D. Copper					250,000	3/4" Black Pipe				
							375,000	3/4" Black Pipe		1" Black Pipe		
							500,000	1" Black Pipe				

- **LP Only:** Seamless copper tubing may only be used with gases that are not corrosive to it. See the note below to check with your LP gas supplier before using copper. Seamless copper tubing must comply with standard type K or L for seamless copper water tube, ASTM B 88; or seamless copper tube for air conditioning field service, ASTM B 280.
- **LP Only:** Copper and brass tubing and fittings (except tin lined) shall not be used if the gas contains more than a trace (0.3 grains per cubic ft.) of hydrogen sulfide gas. Check with your gas supplier.
- **LP Only:** Maximum supply pressure for liquefied petroleum (LP) gas is 13.5" wc and minimum supply for purpose of input adjustment is 11" wc.

Before attempting to measure or adjust high fire manifold gas pressure, the inlet (supply) pressure must be within the specified range for the gas being both used when the heater is in operation and on standby. Incorrect inlet pressure could cause excessive manifold gas pressure immediately or at some future time. With the manual valve, on the combination valve, positioned to prevent flow to the main burners, connect a manometer to the 1/8" pipe outlet pressure tap on the valve. Open the valve and operate the heater to measure the manifold gas pressure. **Note:** A manometer (fluid filled gauge) is recommended rather than

a spring type gauge due to the difficulty of maintaining calibration of a spring type gauge. Normally adjustments should not be necessary to the factory present regulator. If adjustment is necessary, set pressures to above settings by turning regulator screw IN (clockwise) to increase pressure. Turn regulator screw OUT (counter clockwise) to decrease pressure. Consult valve manufacturer's literature provided with the heater for more detailed information.

5.11.3 Gas Heater Location

The following items must be considered when choosing the size and location of the furnace. Note that dehumidifiers designed for outdoor use are already equipped with combustion air intakes and venting means.

- All local codes and/or regulations take precedence over the instructions in this manual and should be followed accordingly. In the absence of local codes, installation must conform to these instructions, regulations of the National Fire Protection Association, provisions of National Electrical Code (ANSI/NFPA70 latest edition), and the National Fuel Gas Code (ANSI Z223.1 latest edition).
- Definitions of "combustible material" and "non-combustible material" as issued by ANSI Z223.1 are as follows:
 - Combustible Material: Material made of or surfaced with wood, compressed paper, plant fibers, plastics or other material that will ignite and burn whether flameproof or not or whether plastered or not.
 - Non-Combustible Material: Material which will not ignite and burn; such materials consisting entirely of steel, iron, brick, concrete, slate, glass, plaster, or combination thereof.
- Measures should be taken to prevent the entry of corrosive chemicals or vapors to the combustion and ventilation air supply. Such chemicals include but are not limited to chlorinated and/or fluorinated hydrocarbons such as found in refrigerants, aerosol propellants, dry cleaning fluids, degreasers, and removers. Other harmful compounds may come from bleaches, air fresheners or mastics. Vapors from such products can form acid compounds when burned in a gas flame. Should acid compounds form in your furnace; it may reduce the life of the furnace. Please follow these guidelines for providing outside air directly to the appliance to avoid this problem.
- The return air duct of the dehumidifier must be sealed air tight to prevent / starvation of the combustion air, especially if the burner is located in a confined area.

Installation should be done by a qualified agency in accordance with these instructions. The qualified service agency installing this separated combustion system is responsible for the installation.

Hazards of Chlorine – The presence of chlorine vapors in the combustion air of gas-fired heating equipment presents a potential corrosive hazard. Chlorine, found usually in the form of Freon or degreaser vapors, when exposed to flame, will precipitate from the compound, and go into solution with any condensation that is present in the heat exchanger or associated parts. The result is hydrochloric acid which readily attacks all metal including 300 grade stainless steel. Care should be taken to separate these vapors from the combustion process. This may be done by wise location of unit vent terminal and combustion air inlet with regard to exhausters or prevailing wind directions. Remember, chlorine is heavier than air. This fact should be kept in mind when determining installation location of these heaters and building exhaust systems.

WARNING

Desert Aire units are not designed or approved for use in atmospheres containing flammable vapors or atmospheres highly laden with chlorinated vapors.

The addition to following the requirements outlined by local codes, follow the guidelines below when locating the vent terminal to help ensure trouble-free operation of your horizontally vented burner:

- Avoid locating the vent terminal on a wall facing the prevailing winds or wide-open areas. When this is not practical, choose locations that protect the vent from strong wind, such as behind a fence or a hedge. (**Note:** The vent terminal must be located sufficiently distant from bushes, shrubs and vegetation so as not to have the flue products restricted or blocked by such vegetation.)
- In areas with considerable snowfall, locate the vent terminal higher than the recommended minimum 12 inches above the ground as protection from blockage by snow accumulation or drifting.
- Locating the vent terminal as close as possible to the outside corner of a building rather than centered on an open wall will also minimize the effect of direct winds. Avoid alcoves and similar areas that may increase wind loading of the vent termination.

Follow these steps outlined in the National Fuel Gas Code, NFPA 54/ANSI Z223.1 – latest edition to resize the vent system to approach the minimum size using the appropriate tables in the Appendix of that code.

The National Fuel Gas Code may be obtained by writing the American Gas Association Laboratories, 8501 East Pleasant Valley Road, Cleveland, OH 44131 or the National Fire Protection Association, Batterymarch Park, Quincy, PA 02269. Refer to the documents located in the heater module for more detailed instructions on installation on your specific terminal unit.

5.12 Electric Heater (Optional) For Packaged Product

In order to keep the controls of the electrical heater cool, there are two openings in the panel adjacent to the heater. The hoods for rain protection of these openings are shipped with the unit, and the mounting hardware is already in place. Mount the hoods over the heater cooling openings using this hardware.

5.13 Auxiliary Heat Coil Piping (Optional)

The Desert Aire dehumidifier may be equipped with an optional hot water or steam air heating coil. This coil, when properly sized, will provide space heating during the winter months. Use proper practice when designing and installing the coil piping to prevent poor coil performance, shortened service life, or damage to the coil.

- The supply connections must not be supported by the coil headers.
- The control valve should be sized according to the pressure and flow rate requirements not by the coil connection size.
- On steam systems, use strainer, dirt pockets, and isolation valves to prevent clogging the control valve and to simplify service.
- Install swing joints in the connection piping to prevent damage to the coil header from thermal expansion.
- Use a backup wrench on the pipe stubs when attaching connections to prevent damage to the header.

5.14 Roof Curb w/ Wood Nailer (if applicable)

Certain options for curbs shipped with the packaged units include a treated wood nailer and flashing installed on the side of the curb. This allows for draining of the pan installed under the condenser section. The nailer and flashing should be carefully inspected on final installation of the roof material. Any separation of the flashing from the curb due to transportation and lifting will cause water to penetrate behind the flashing and past the roof materials. Re-caulk as required to close any gaps that may have occurred.

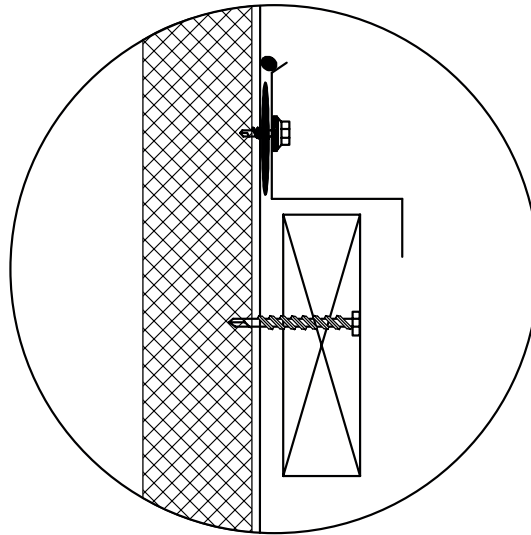

Figure 32: Wood Nailer

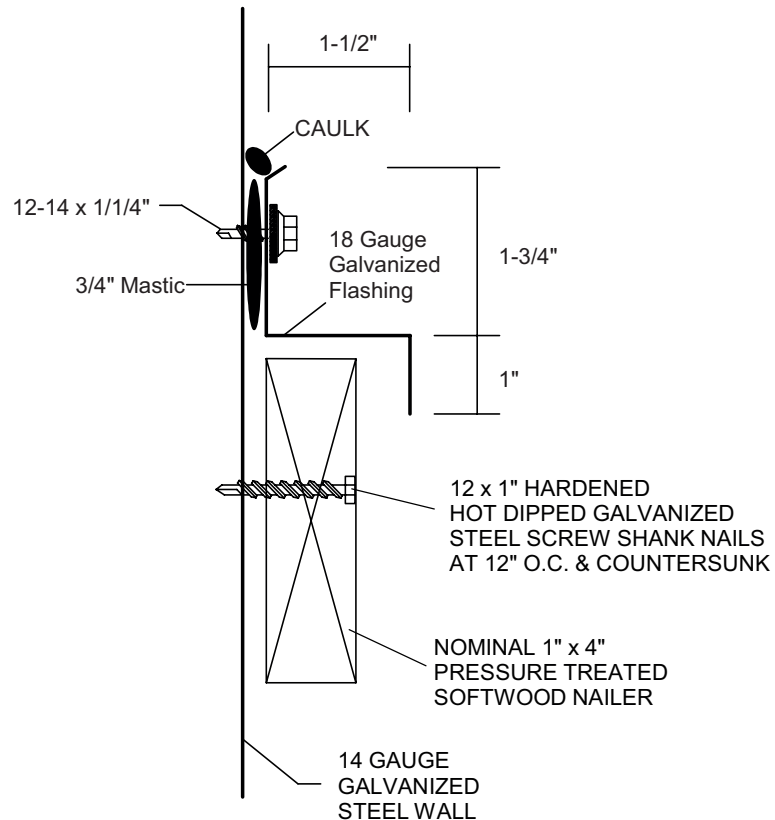

Figure 33: Wood Nailer Detailed

6 Start-up Procedure

Read this section thoroughly before attempting to commission the Desert Aire dehumidifier. A complete start-up will minimize operational problems and expensive callbacks. The start-up will be quicker and easier if there is a heat and humidity load present in the space. Energize any auxiliary heaters before start-up so that the air is at the design temperature.

6.1 Preliminary Inspection

Verify that all contractors have completed their work. Find the Desert Aire “LC and LV Start-up Report,” which is normally placed inside this manual within the electrical compartment of the dehumidifier. You must fill out the start-up report to validate the dehumidifier warranty.

Check the following items:

- Before starting unit, remove wooden shipping blocks found beneath compressor(s).
- Before starting unit, remove shipping restraining brackets on supply blower equipped with a spring isolation base, if applicable.
- Make sure that the unit is level and securely mounted so that it cannot shift or transmit vibration to the building.
- Verify that the incoming power supply matches the rating plate of the dehumidifier. The available power supply voltage must be within $\pm 5\%$ of the voltage printed on the rating plate.
- With the power supply disconnected and locked, tighten all field and factory electrical connections.
- Check and adjust the belt tension for proper deflection at the mid-point of the blower belt(s).
- The deflection is based on the belt length. The belt length can be found on the belt itself. Determine the force using the Belt Deflection Force table below.

Table 16: Specified Belt Deflection Table

Specified Belt Deflection	
Belt Length	Deflection
25" to 50"	0.25"
51" to 70"	0.375"
71" to 110"	0.625"

Table 17: Belt Deflection Force Table

Belt Deflection Force						
HP	New Belt Force (lbs.)			Used Belt Force (lbs.)		
	1 Belt	2 Belts	3 Belts	1 Belt	2 Belts	3 Belts
0.5	3			2 - 2.5		
1						
1.5						
2						
3	7			5-6		
5						
7.5						
10	12	7		9-10	5-6	
15						
20		12	12		8-9	8-9
25						
30						
40						

- Inspect the air filters and coils to ensure they are clean. If necessary, clean the coils and install new filters.
- Check the field and factory piping for leaks. The internal piping may have been damaged during shipping.
- Purge any air, dirt, or debris from water lines (if used) to avoid clogging the internal passages of optional heating coils or water side heat exchangers.
- Check the drain pan and the condensate piping. Test the drain and prime the P-trap by pouring water into the drain pan.
- Verify that all service valves in the refrigeration lines are fully open.

6.2 Gas Heater Start-up (Optional)

This optional furnace does not have a pilot. It is equipped with an igniter that automatically lights the burner. Do not attempt to light the burner by hand. Check the following items before the initial start-up:

- Check all wiring for loose connections and proper hookup. Leak test the gas piping connections.
- Check the rubber tubing to the inducer fan pressure switch to make sure it is pushed firmly onto the pressure tap.

It may be necessary to purge the air out of the gas line for initial start-up of the furnace after installation. This should be done by a qualified heating contractor. If excessive gas escapes when purging the gas supply at the union, allow the area to ventilate for at least 15 minutes before attempting to start the furnace. LP gas is especially dangerous because it is heavier than air and can accumulate to dangerous concentrations at floor level. Heat exchanger oil will burn off on initial firing creating an unpleasant odor. To prevent this odor from occurring more than once, open doors and windows and run the blower for at least 30 minutes or until odor disappears. The orifice for the burners was sized for either natural gas (having a heating value of 1025 BTU per cubic foot and a specific gravity of 0.60) or for liquefied propane gas (with a heating value of 2500 BTU per cubic foot and a specific gravity of 1.53). See the rating plate of your dehumidifier to determine which type of fuel the heater is configured for.

To verify the actual input of your natural gas burner, proceed as follows:

- Call your gas supplier and ask for the BTU content (heating value) of one cubic foot of the gas supplied to the installation area. An alternate approach is to assume a value of 1025 BTU/ft³, which is the national average.
- With all other gas appliances turned off, operate the burner for at least ten minutes. After the equipment has warmed up, use a stop watch to clock the time required for the small dial on the gas meter to make one full revolution. A label on the meter will state how many cubic feet have flowed per revolution (usually one, two or five).

Input BTU/hour = (BTU/ft³ x ft³ x 3600 seconds) / (seconds / revolution)

EXAMPLE: (1025 BTU/ft³ x 2 ft³ x 3600) / 74.8 seconds = 98,663 BTU Input

Check for the input of the burner, the type of gas, and the required manifold pressure on the rating plate located on the exterior of the dehumidifier. Make sure that the gas supply pressure to the furnace falls within the maximum range of 6" to 14" wc pressure for natural gas and 11.0" to 14.0" wc for LP gas. The pressure to the furnace must be checked while the furnace burner and any other gas appliances on the same supply system are operating.

The burners are equipped with fixed orifices sized for the manifold pressure shown on the rating plate. The input can only be increased or decreased by adjusting the manifold pressure. Remove the 1/8" threaded pipe plug located on the top right side of the gas valve. Use a U-tube manometer or a pressure gauge to measure the pressure. To adjust the pressure, remove the screw from the regulator on the outlet side of the gas valve. Turn the adjustment screw counterclockwise to decrease the pressure or clockwise to increase the pressure.

ADJUSTMENTS TO THE LISTED PRESSURE MUST NOT EXCEED 0.3" wc.

A 0.3" wc adjustment will increase or decrease the input approximately 0.4%. Replace the screw cap when the adjustment is complete. Shut off the gas supply to the furnace. Remove the pressure gauge and re-install the pipe plug using a threaded compound resistant to the action of LP gases.

If the rated input cannot be obtained with the present orifice at the correct pressure, your local gas supplier will assist in sizing the proper orifice. The Desert Aire Service Department will gladly help you size the orifice if you provide them with the heating value in BTU per cubic foot and the specific gravity of the gas.

6.2.1 Burner Adjustment

Burner air shutters are not normally required on natural gas furnaces. Air shutters are required on propane gas units and may require adjustment. Before making any adjustments to the air shutters, allow the heater to operate for about fifteen minutes with the air shutters open. The slotted screw on the end manifold bracket moves the air shutters and adjusts all burners simultaneously. Turning the screw clockwise opens the shutters; counterclockwise closes the shutters. After the furnace has been in operation for 15 minutes, close the air shutters observing the flame for yellow-tipping. Open the shutters until the yellow disappears. A limited amount of yellow tipping is permissible for liquefied petroleum gases. Natural gas should not display any yellow-tipping. When making the adjustment, close the air shutters no more than is necessary to eliminate the problem condition. After 15 – 20 minutes if the outlet or supply duct temperature is too high, you must balance the supply airflow.

6.3 Outdoor Air Application

6.3.1 Outdoor Air Option Equipped Units

Construction codes often require you to introduce outdoor air into a commercial building while it is occupied. Desert Aire dehumidifiers can be factory-configured to help you comply with these codes. Several factory-installed options, which are available by special order, can

include flanging for an outdoor air duct connection and a fresh air intake box with air filters and a damper.

The CM3530 microprocessor controller can be programmed to set occupied and unoccupied operation times on LC and LV Series dehumidifiers. LC and LV units ordered with the outdoor air intake option are provided with an automatically controlled outdoor air intake damper. When ordered with an outdoor air intake option, refer to the Desert Aire LC/LV control schematic.

NOTE: You must provide a transformer or a power source for the relay R2 and the outdoor air damper and the exhaust blower contactor. An outdoor air intake damper can be factory installed and powered by the unit as well.

You must install an exhaust blower whenever you bring outdoor air into a dehumidified room. Without the exhaust fan, the room would be at a positive pressure. This increased room pressure can drive moisture and chlorine odors into insulation, building materials, and adjacent rooms. Size the exhaust blower to maintain the dehumidified room at a neutral or slightly negative pressure.

You must install the outdoor air intake away from any sources of airborne contamination such as exhaust fans or plumbing vents. You must also filter the outdoor air before it comes in contact with any coils. Insects and debris in the unfiltered air will rapidly clog the dehumidifier's reheat condenser coil, which will lead to repeated service calls and eventually equipment damage.

If mixed air temperatures in the system's blower compartment falls below 45°F an internal safety thermostat will de-energize and override a call for outdoor air. This safety mode will remain active until mixed air temperatures in the blower compartment rise above 55°F.

IF OUTDOOR TEMPERATURES IN CONJUNCTION WITH YOUR OUTDOOR AIRFLOW RATE ARE CAPABLE OF TRIPPING THE SAFETY THERMOSTAT, YOU MUST INSTALL AN OUTDOOR AIR PRE-HEATING COIL.

Refer to section 6.3.4 to determine if the pre-heating of outdoor air is required for your application. An example of proper outdoor air installation is shown in Figure 34.

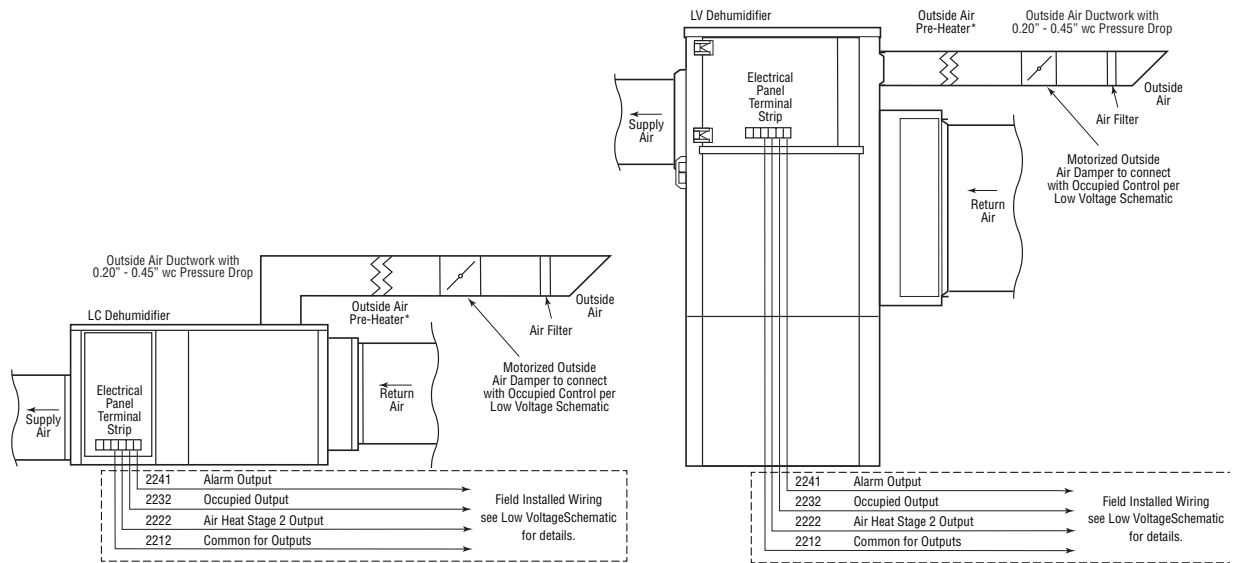

Figure 34: Proper Installation for an Outdoor Air Application

NOTE: Desert Aire LC and LV Series dehumidifiers are designed to handle a range of external static pressures. In applications where strict outdoor air code compliance is required, proper system airflow must be determined by a professional balancing contractor. When an approximation of outdoor air volume is all that is necessary, the procedures detailed in section 6.3.5 can be used.

6.3.2 Standard Systems in Conjunction with Outdoor Air

The introduction of outdoor air into the return air duct can lead to a number of problems. This is not recommended and will void the warranty in most instances. Contact the Desert Aire Service Department before proceeding with such an installation. If outdoor air must be added to satisfy code requirements on a non-outdoor air equipped system, it is advised that the intake and exhaust be connected directly to the space being conditioned.

SYSTEM FAILURES CAUSED BY IMPROPER OUTDOOR AIR INSTALLATIONS ARE NOT COVERED BY WARRANTY.

6.3.3 Outdoor Air Supplemental Information

6.3.3.1 LC and LV Operation Modes

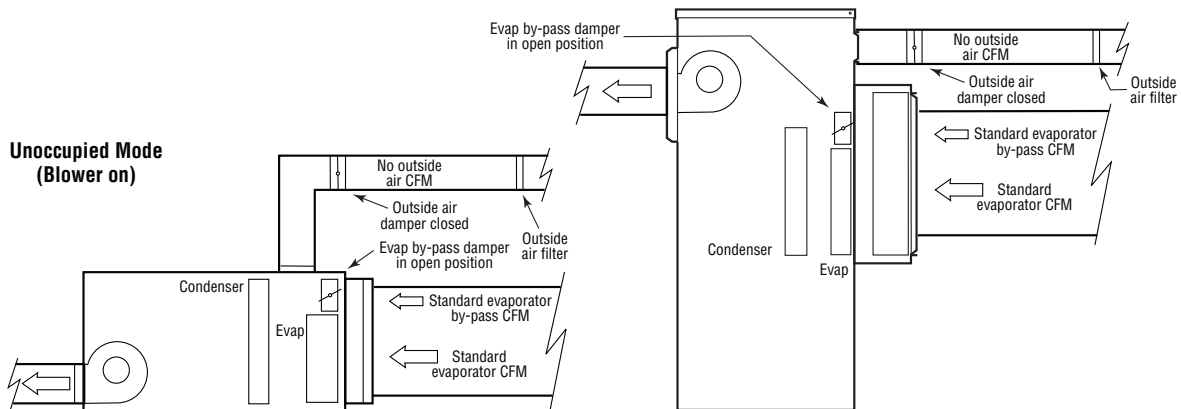

Figure 35: LC Models left; LV Models right - Unoccupied Mode Operation

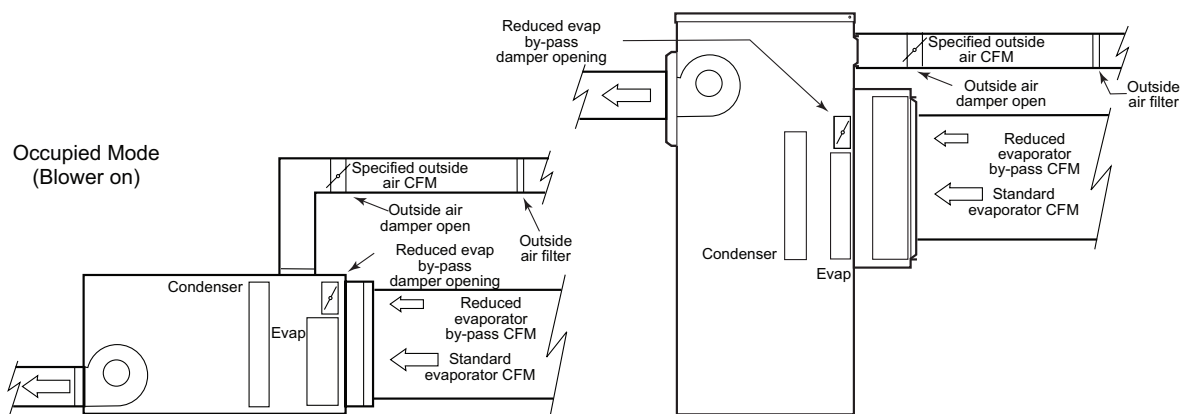

Figure 36: LC Models left; LV Models right - Occupied Mode Operation

6.3.4 Determining if Outdoor Air Pre-Heating is Required

Desert Aire systems require that outdoor air be pre-heated if mixed air temperatures inside the unit may fall below 45°F. To determine if an application requires outdoor air pre-heating, the following study needs to be conducted:

1. Determine the following:
 - Design return air temperature. For pool rooms, typically 82°F
 - Outdoor air winter design temperature. Use values as specified by design engineer or ASHRAE tables
 - Total system CFM and required outdoor air CFM
2. Determine worst case Mixed Air Temperature (MAT) using the following equation:

$$\text{MAT} = \frac{(\text{winter temp } ^\circ\text{F}) \times (\text{OA CFM})}{(\text{system CFM})} + \frac{(\text{return air temp } ^\circ\text{F}) \times (\text{system CFM} - \text{OA CFM})}{(\text{system CFM})}$$

3. If MAT is less than 45°F, then the pre-heating of outdoor air is required

NOTE:

- Proper system airflow and outdoor air CFM must be confirmed at the time of installation
- Outdoor air duct must be equipped with filters and a motorized damper provided by installing contractor or as optional equipment on Desert Aire dehumidifiers.
- Outdoor air duct must be insulated to prevent condensation which may form on the exterior of the duct during winter months

LC EXAMPLE: LC05 (2300 system CFM), pool room application, 500 CFM of outdoor air. Location: Minneapolis, Minnesota. Winter Temp: -16°F

$$\text{MAT} = \frac{(-16^\circ\text{F}) \times 500}{60.7^\circ\text{F} \ 2300} + \frac{82^\circ\text{F} \times (2300 - 500)}{2300} =$$

CONCLUSION: No need for outdoor air pre-heat

LV EXAMPLE: LV05 (3000 system CFM), pool room application, 500 CFM of outdoor air. Location: Minneapolis, Minnesota. Winter Temp: -16°F

$$\text{MAT} = \frac{(-16^\circ\text{F}) \times 500}{65.7^\circ\text{F} \ 3000} + \frac{82^\circ\text{F} \times (3000 - 500)}{3000} =$$

CONCLUSION: No need for outdoor air pre-heat

6.3.5 Approximating Outdoor Air Volume

When servicing or installing a Desert Aire unit, it may be necessary to determine and/or set the amount of outdoor air CFM entering the unit. Proper outdoor air CFM settings can be approximated using two simple equations as follows:

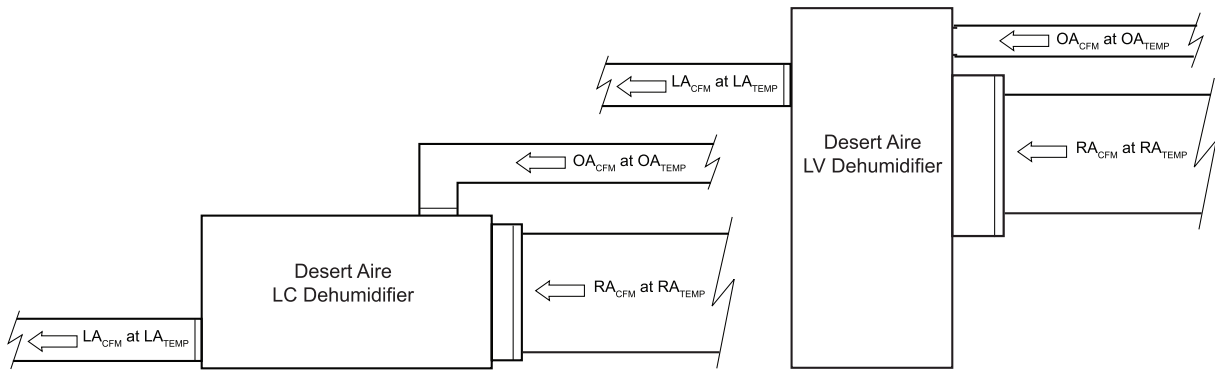

Figure 37: Approximating Outdoor Air CFM

$$OA_{CFM} = LA_{CFM} \times (LA_{TEMP} - RA_{TEMP}) / (OA_{TEMP} - RA_{TEMP})$$

$$LA_{TEMP} = (OA_{CFM} \times (OA_{TEMP} - RA_{TEMP}) / LA_{CFM}) + RA_{TEMP}$$

NOTE:

- This method is just an approximation! In applications where strict code compliance is required, proper airflow must be determined by a professional testing and balancing contractor.
- Refrigeration circuit must remain inactive during this procedure (blower on only).
- When measuring air temperatures, several readings must be taken across a duct and averaged.
- Proper LA_{CFM} (total system airflow) must be confirmed prior to this procedure. This is done by achieving specified airflow pressure drop across the reheat coil. See section 3.3 for details.

EXAMPLE 1: Determine how much OA_{CFM} is entering an LC05

Measured: $LA_{CFM} = 2300$, $LA_{TEMP} = 73^{\circ}F$, $RA_{TEMP} = 82^{\circ}F$, $OA_{TEMP} = 40^{\circ}F$

Solution: $OA_{CFM} = 2300 \times (73^{\circ}F - 82^{\circ}F) / (40^{\circ}F - 82^{\circ}F) = 490$ CFM

6.4 Airflow Balancing

To ensure code compliance and long equipment service life, proper airflow must be verified by a qualified air balancer. Shut off the compressor to prevent the refrigeration system from running while you balance the air.

6.4.1 Units with an EC Blower

The speed of these blowers is controlled by a 0-10 V signal from the controller. Airflow monitoring is achieved within the unit based on differential pressure measured by a transducer. Airflow rate is maintained by a control loop which varies the signal to the blower in order to achieve the differential pressure associated with the required airflow.

Once the airflow is adjusted, review the motor current draw. If the current draw is in excess of the current rating listed on the unit nameplate or the drive is unable to achieve the airflow at the maximum setting, the unit may be experiencing external static pressure in excess of the design condition. Check the external static of the ducting to/from the unit and reduce it until it is equal to or less than the design condition indicated on the rating plate. If issues persist, consult the Desert Aire Service Department 262-946-7400. Prior to any calls to the Desert Aire Service Department please have the unit serial number and model number available.

6.4.2 Blower Adjustment Procedure For Non-EC Blower Units

! WARNING

Disconnect Power to the Unit before you adjust the Blower.

Change the blower speed by adjusting the motor pulley. To adjust the variable pitch pulley, first loosen the set screw. To slow down the blower, turn the outer pulley face counterclockwise (to decrease its pitch diameter). To speed up the blower, turn the outer pulley face clockwise (to increase its pitch diameter).

After every adjustment be sure to:

- Tighten the set screw against the flat spot on the pulley hub so you don't damage any threads.
- Adjust the belt tension if needed.
- Check to assure that the blower motor current draw does not exceed the rating printed on the rating plate.

If the blower motor current draw exceeds its rating but your airflow is still too low, the static pressure losses in the ductwork and grilles may be higher than the unit was designed for. If this happens, consult the Desert Aire Service Department at 262-946-7400. Prior to any call to the Desert Aire Service Department please have the unit serial number and model number.

6.4.3 Airflow Balancing for LC Dehumidifiers Without EC Blower

The total airflow of a Desert Aire LC system can be checked by measuring the static pressure drop across the reheat condensers and the evaporator coils. The dehumidifier features an adjustable blower sheave to simplify air balancing.

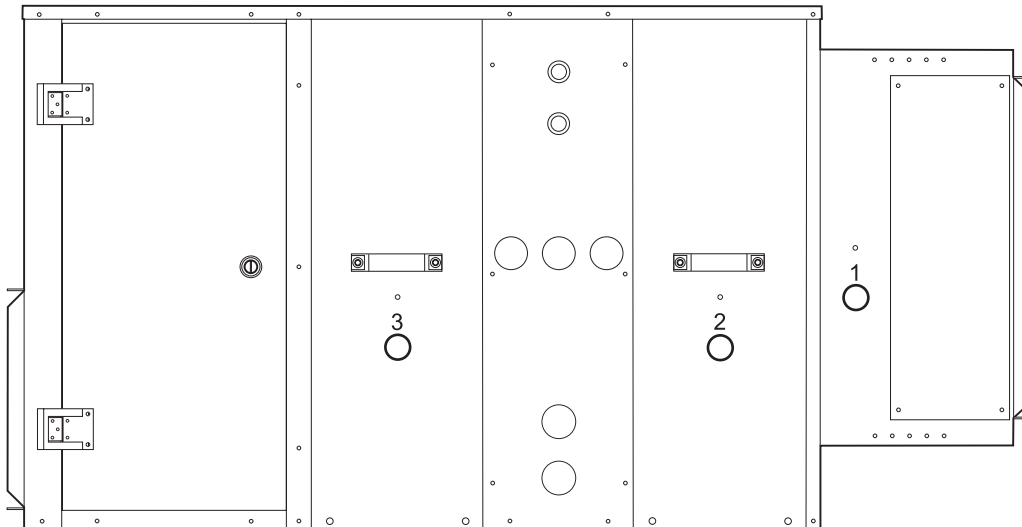

Figure 38: LC Air Balance Ports

Procedure:

- Check condition of the air filter(s) to assure that they are clean.
- Check for any obvious restrictions in the ductwork.
- Start the supply air blower.
- Index unit to unoccupied mode. This can be done by setting the number of active occupied schedules to “0” AND ensuring the occupancy jumper is not installed. Building management system network occupancy signal should be indexed to “Off” if equipped. All three methods of occupancy command must be in the unoccupied position. Check the unit display STATUS screen to ensure unit is in the unoccupied mode.
- Confirm outdoor air damper is closed.
- Use a manometer or magnehelic pressure gauge to measure the static air pressure differential across the reheat condenser (ports #2 and #3 above). Reading should be within limits indicated in Table 18. Adjust the fan speed as required to achieve the indicated pressure differential.
- Use the manometer or magnehelic pressure gauge to measure the static pressure differential across the evaporator coil (ports #1 and #2 above). Reading should be within limits indicated in Table 19. Adjust the evaporator bypass damper opening by using the control interface to adjust the “Evap” “Unocc” damper setting. This is located in the DAMPER SETTINGS menu under the SERVICE MENU. Adjusting the value to a greater percentage will open the damper and decrease the pressure differential. Adjusting the value to a lower percentage will close the damper and increase the pressure differential. Use only the controls to adjust the damper position. Do not manually limit the stroke of the damper by using mechanical stops.
- Use a manometer or magnehelic pressure gauge to re-check the static air pressure differential across the reheat condenser (ports #2 and #3 above). Adjust the fan speed as required to achieve the indicated pressure differential.
- Index unit to occupied mode. This can be done by setting the number of active occupied schedules to “1” and ensuring that the current time is within the occupancy time of the first schedule. Alternatively, the occupancy jumper can be installed or the building management system can be connected and the network occupancy signal should be indexed to “On”. Any one of the three methods can be used, but it is recommended that the method that will be used in normal unit operation be tested during this step. Check the unit display STATUS screen to ensure unit is in the occupied mode.
- Confirm outdoor air damper opens and exhaust fan (by others) is energized.
- Measure outdoor air flow rate with hood, duct traverse, or other measurement method appropriate for the installation. Airflow rate can be adjusted by the “OA” “Occ” damper setting in the DAMPER SETTINGS menu of the controls.
- Note that the flow rates for outdoor air are application specific. Refer to the mechanical equipment schedule or other indication from the building designer for required flow rates.
- Use the manometer or magnehelic pressure gauge to measure the static pressure differential across the evaporator coil (ports #1 and #2 above). Reading should be within limits indicated in Table 19. Adjust the evaporator bypass damper opening by using the control interface to adjust the “Evap” “Occ” damper setting.
- Measure exhaust system air flow rate at the fans or blowers by others with hood, duct traverse, or other measurement method appropriate for the installation. Note that the flow rates for exhaust air are application specific. Refer to the mechanical equipment schedule or other indication from the building designer for required flow rates. Poolroom applications will require the exhaust air flow rate to be greater than the outdoor air to maintain a negative static pressure in the space.

6.4.4 Airflow Balancing for LV Dehumidifiers

The LV series has static pressure sensors up and downstream of the reheat condenser. The hose barb connections (for 3/16 or 1/8” I.D. tubing) of the sensors are accessible in the lower compartment on the LH side of the unit. The sensors are mounted toward the return end through the mid cap/pan.

The static pressure sensors are used together with a manometer to measure the static pressure differential across the heat exchanger. Connect the sensors to a manometer with

appropriate hoses to measure the pressure drop (in inches of water column) of the airflow through the reheat condenser. The design pressure drop of the airflow is listed on a label on the compartment door. The static pressure sensors should be covered when not in use to prevent dirt from clogging the orifices. These sensors may be used with the electric heat airflow interlock for proof of flow.

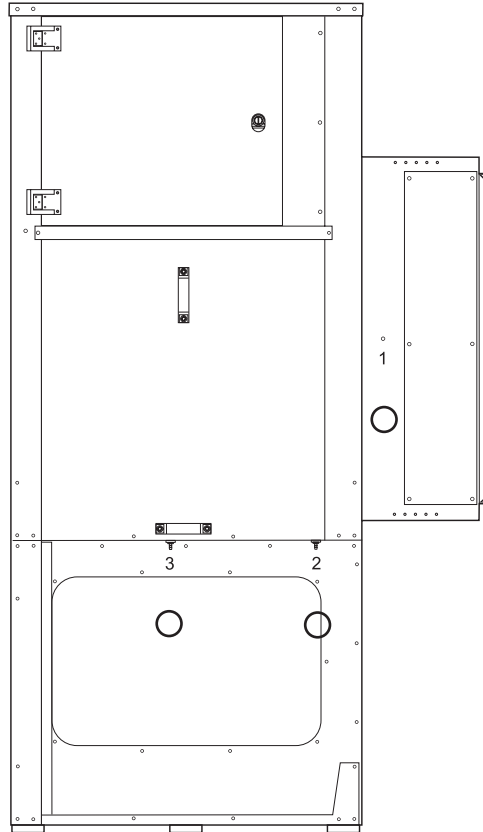

Figure 39: LV Air Balance Ports

Table 18: Standard Reheat Coil Pressure Drops

Model (LC Only)	Total System CFM	Condenser Coil Pressure Drop Range (Inches W.C.)	Condenser Coil + Hot Water Coil Pressure Drop Range (Inches W.C.)
01	540	0.10" - 0.12"	0.25" - 0.27"
02	950	0.25" - 0.27"	0.43" - 0.45"
03	1400	0.24" - 0.26"	0.34" - 0.36"
04	1900	0.15" - 0.17"	0.24" - 0.26"
05	2300	0.21" - 0.23"	0.31" - 0.33"
06	3000	0.30" - 0.32"	0.44" - 0.46"
08	3500	0.38" - 0.40"	0.57" - 0.59"
10	4100	0.27" - 0.29"	0.39" - 0.41"
12	5500	0.43" - 0.45"	0.71" - 0.73"
15	8000	0.40" - 0.42"	0.69" - 0.71"

Model (LV Only)	Total System CFM	Condenser Coil Pressure Drop Range (Inches W.C.)	Condenser Coil + Hot Water Coil Pressure Drop Range (Inches W.C.)
03	1500	0.24" - 0.26"	N/A
04	2100	0.18" - 0.20"	N/A
05	3000	0.32" - 0.34"	N/A
06	3400	0.37" - 0.39"	N/A
08	3800	0.44" - 0.46"	N/A

Table 19: Evaporator Pressure Drop

Evaporator Pressure Drop

Tons	pD Dry	pD Wet
01	0.14	0.21
02	0.19	0.30
03	0.24	0.42
04	0.12	0.20
05	0.18	0.29
06	0.21	0.36
08	0.24	0.43
10	0.23	0.42
12	0.20	0.31
15	0.20	0.32

6.5 Refrigeration Testing

Refrigeration based cooling systems are sometimes referred to as “sealed systems”. This is in reference to the refrigeration system being hermetically sealed, no refrigerant can leave the system and no contaminants are allowed inside. Factory equipment and procedures ensure a clean and tight refrigeration system where only the specified refrigerant and oil are in the system. This is a critical component to the longevity of the system. Some Desert Aire systems are shipped in sections to allow for installation of some of the sections in a location much different than another. An example is a unit with a remote condenser ready circuit. The dehumidifier may be installed indoors near the conditioned space while the remote condenser used to reject waste heat is located outdoors. The piping of the condenser is completed in the field before the unit is commissioned. The design and processing of the field piping is just as important as the factory piping in ensuring the longevity of the system. Selection of quality components, quality procedures, and full testing help to ensure the sealed system failures are minimized wherever possible. Nonetheless, the mechanical nature of many components creates some unforeseen wear and failure in certain instances. Some units may need service at a point in the life of the product that requires opening of the hermetic refrigeration system. Special care must be taken to ensure that the system is returned to service without contamination.

Whenever servicing Desert Aire equipment, observe the following:

- Use only equipment rated for the pressures of the refrigerant being serviced.
- Use only equipment dedicated to service of the refrigerant in the system. Do not use equipment to service multiple refrigerant types.
- Purge all hoses and equipment of non-condensable gasses before connecting to the sealed system.
- Use only original equipment parts or factory approved equivalent for servicing.

- Oil added to the system should be from new, sealed containers. New systems with R-454B should use only the following oils:
 - Copeland® Ultra 32-3MAF
 - Lubrizol Emkarate RL 32-3MAF
 - Parker Emkarate RL 32-3MAF
 - Nu Calgon 4314-66 (RL 32-3MAF). SCA
- Minimize the time the system is open to atmosphere while servicing. Cap all connections when there is no active service work on the system. This is particularly important with units that contain POE oils as moisture will be absorbed quickly and cannot be removed with a vacuum.
- Never open the system while under a vacuum. Should the system require opening to repair a leak or other service when in a vacuum, fill with dry nitrogen to atmospheric pressure before opening.
- Have a Schrader core replacement tool available when servicing the refrigeration system. Although rare, defective or damaged Schrader valve cores can contribute to refrigerant loss.
- Charge systems only by weight after servicing. Review the rating plate and any field charge labels.
- When servicing, additional liquid line filter dryers and suction filters may be required. This does not apply to installation of remote condensers.
- Charge refrigerant blends, including R-454B, with liquid only. Charging should be done into the high side of the system whenever possible. Refer to section 5.5 for additional procedures related to charging. Note that the superheat should be stable and within 4 degrees of fluctuation. Minimum value for superheat at compressor in all modes:

Table 20: Superheat Minimum Values Chart

Superheat Minimum Values Chart Temp (°F)							
Relative Air Temperature (°F)		65.0 - 70.0	70.1 - 75.0	75.1 - 80.0	80.1 - 85.0	85.1 - 90.0	90.1 - 95.0
Relative Air Humidity (%RH)	30.0 - 40.0	12	13	14	14	15	15
	40.1 - 50.0	13	13	14	15	15	16
	50.1 - 60.0	14	14	15	15	16	16
	60.1 - 70.0	15	15	15	16	16	17
	70.1 - 80.0	15	15	15	16	17	18
	80.1 - 90.0	15	16	16	17	18	

6.6 General Testing

After you balance the airflow and test the refrigeration circuits, verify that the other equipment and accessories connected to the dehumidifier work properly. Although this may be difficult, since the dehumidifier is usually interlocked with a variety of equipment installed by different contractors, you must not skip this step. Each of these devices (which may include auxiliary air and water heaters, smoke alarms, circulating pumps, and a building management system) is vital in maintaining the performance of the unit. Many customer complaints are caused by improper interlocks between these devices. Make sure you check the following:

- Check the outdoor air and exhaust devices. The outdoor air and exhaust dampers must open when they receive an “occupied” signal from the dehumidifier. If you have installed an exhaust blower, make sure that it is interlocked with the “occupied” signal or with an end switch on the outdoor air damper actuator.
- Check the condensate drain to make sure it has been trapped and primed with water. Verify that it drains freely, with no leaks. If the drain is outside or in an unconditioned space, make sure it has been heat traced. If you installed a condensate pump, make sure it operates properly.
- Check the operation of the remote condenser (on units equipped with this option). Make sure that

the fans cycling switches, which are mounted on the condenser, are correctly piped and have been set according to the Desert Aire condenser wiring diagram. Verify that the fans are blowing air vertically upward when they run.

- Check the temperature and humidity readings displayed on the controller. If you think the values are incorrect, check the sensor or its field-installed wiring for damage.
- Check the operation of the auxiliary heaters by temporarily raising the air temperature set point on the Desert Aire controller. The duct heater(s) or heating valve should energize.

6.7 Routine Maintenance Schedule

6.7.1 Service Every Month

- Check the air filters and replace them if necessary.
- Check the coils in the dehumidifier and the remote condenser. Use compressed air or a commercial coil cleaner if they are dirty or plugged.
- Verify that the air flow around the remote condenser remains unobstructed.

6.7.2 Service Every Six Months

- Check the blower belts for wear or glazing. Tighten or replace them if necessary. Do not use the belt dressing compound.
- Check and tighten all field and factory electrical connections.
- Check for dirty coils in the dehumidifier and the optional remote condenser.
- Check and clean the drain pans and blow out the condensate drain line. If the drain is plugged, water will back up into the dehumidifier and flood the mechanical room.
- Check and adjust the air flow per specifications. Dirty ducts, filters, and coils may have reduced the total air volume.
- Check the operating pressures of the refrigeration circuits.
- Check the current draw of each blower motor.
- Check the current draw of each compressor.
- Lubricate the blower motor(s), if applicable.
- Lubricate the blower bearings, if applicable

Table 21: Grease Suggested Brands and Types

Supplier	Type	Base	Range temperature (min-max)
FINA	Marson HTL 3	Lithium	-30°C / +120°C
SHELL	Alvania Fett 3	Lithium	-20°C / +130°C
ESSO	Beacon 3	Lithium	-20°C / +130°C
MOBIL	Mobilux EP3	Lithium	-30°C / +130°C

6.7.3 Gas Heater (Optional)

Dehumidifiers equipped with optional gas heating should be inspected annually before each heating season. Check the following items:

- Ensure that the vents and air intakes are clean and unobstructed.
- Clean the vent and condensate drain line if necessary. Repair any damaged sections of the vent.
- Inspect the pressure switch tubing connections. Verify that the inducer fan is free of corrosion, warpage, deterioration, and carbon buildup. If necessary, clean the housing and the blower wheel with a damp cloth. Vacuum any lint or dust from the inducer motor assembly.

See the separate gas heater manual for detailed service information.

Note: Please have the following information available if you need to call the Desert Aire Service Department:

Table 22: Provide the Following Information When Contacting Desert Aire Service Department

Model Number:		Operating Refrigeration Pressures	
Serial Number:		Water Temperature:	
Room Temperature:		Compressor Amperage:	
Relative Humidity:		Blower Motor Amperage(s):	

6.7.4 Pool Water Chemistry

Pool chemistry must be maintained to ensure the proper pH, total alkalinity, calcium hardness and free chlorine. NSPI recommends the following levels for pool chemistry:

pH:	7.4-7.6
Total Alkalinity (ppm):	100-150
Calcium Hardness (Plaster Pool) (ppm):	200-250
Calcium Hardness (Vinyl or Painted Pool) (ppm):	175-225
Free Chlorine (ppm):	1.0-3.0

Excessive chemical levels in the pool can be dangerous to users and can damage pool hardware, including the dehumidification system. **SERVICE PROBLEMS CAUSED BY EXCESSIVE CHEMICAL LEVELS ARE NOT COVERED UNDER WARRANTY.**

7. Troubleshooting

Although Desert Aire dehumidifiers have been designed for reliable and trouble-free operation, you may occasionally encounter a service-related problem. If you cannot immediately diagnose and fix the problem, do not be intimidated by the apparent complexity of the dehumidifier. Your common sense and experience can help you solve the majority of these problems. These problems or complaints are frequently caused by improper interlocks between the dehumidifier and the other equipment and accessories at the jobsite. You may need to consult with other contractors who have worked on different portions of this project. The following list will help you diagnose some of the most obvious symptoms of a system which does not work properly.

7.1 The Blower Does Not Run

POSSIBLE CAUSE	REMEDY
System terminal switch in open position	Close system terminal switch.
Loss of main power	Check for tripped circuit breaker or blown fuses.
Blower overload has tripped	Correct cause and reset overload.
Faulty control wiring	Check for loose or incorrect wires on system and controller.

7.2 The Compressor Does Not Run

NOTE: Under some circumstances the compressor will not run even though the humidity in the room may be too high. See section 8.4 for more information on the control sequence for the dehumidifier.

POSSIBLE CAUSE	REMEDY
Control logic	A) Adjust controller set points. B) On RR/ER models with a remote condenser installed, verify that the RC jumper has been installed in dehumidifier and the ROC is enabled in the service menu
Loss of main power	Check for tripped circuit breaker or blown fuse(s)
Blower overload has tripped	Correct cause and reset overload
Faulty wiring	Check for loose or faulty wiring on system and controller.
Compressor overload has tripped	Correct cause and reset overload.
Comp. failure may have occurred if: A) Comp. draws locked rotor amps B) Comp. starts but does not pump C) Motor windings have shorted	A) Replace compressor (or check fuses on three-phase units). B or C) Replace Compressor.
Compressor delay-timer	Wait 6 minutes for timer.
Verify "Low Airflow" is not displayed on the control	Verify airflow across reheat coil

7.3 Evaporator Coil Ices Up

POSSIBLE CAUSE	REMEDY
Entering air below 70°F	Raise entering air temperature
Faulty or improperly set hot-gas bypass valve	1) Set hot-gas valve to maintain 32°F suction. 2) Replace if defective. 3) Open hot-gas isolation valve.
Insufficient evaporator airflow rate	1) Evaluate system airflow. 2) Check for dirty filters or restricted ductwork. 3) Assure coils are clean.
Lack of refrigerant	Re-evaluate system charge.
Restrictive filter drier	Evaluate filter pressure drop and replace if necessary.
Defective expansion valve	Evaluate expansion valve performance and replace if necessary.
Restriction in refrigeration piping	1) Check coil for kinks in tubing. 2) Evaluate debris in distributor.

7.4 Head Pressure is Too High

POSSIBLE CAUSE	REMEDY
Insufficient system airflow	1) Evaluate system airflow 2) Check for dirty filters or restricted ductwork. 3) Verify that coils are clean.
Excessive refrigerant charge	Re-evaluate system charge.
Non-condensables in system	Evaluate or purge system.

POSSIBLE CAUSE	REMEDY
Defective refrigeration valves	Check 3-way, flooding, solenoid and check valves for sticking.
Restriction in refrigeration piping	1) Check coil and tubing for kinks. 2) Replace dirty drier filter.
Refrigeration system is overloaded	1) Reduce entering air temperature or relative humidity. 2) Check register locations for short cycling of air.
Low water flow	Evaluate water flow rate for your application.
REMOTE CONDENSER PROBLEMS WHICH CAUSE EXCESSIVE PRESSURES	
Lack of airflow	Assure coil is clean and no airflow restrictions exist around unit
Remote condenser fan troubleshooting	
1) Faulty Contactor	1) Replace contactor.
2) Fan cycling on internal protection	2) Verify motor voltage and ensure free spinning motor shaft.
3) Remote condenser jumper missing at dehumidifier	3) Add necessary jumper in dehumidifier.
4) Pressure control inactive	4) Verify pressure control cut-in and differential settings.
Service valves closed or not fully open	Fully open service valves.
Excessive pressure drop in line sets	Re-evaluate remote condenser installation

7.5 Unit Runs but Excess Condensation on Walls and Windows

POSSIBLE CAUSE	REMEDY
Air and pool water temperature imbalance	Adjust set points so that air temperature is 2°F above water temperature. 80°F water and 82°F air recommended for most jobs.
Poor air distribution	Evaluate duct design and dehumidifier location.
Unit airflow is too high	Evaluate system airflow.
Unit is undersized	Re-evaluate unit sizing. Check for initially neglected sources of heat or humidity.
UNITS EQUIPPED WITH WALL- MOUNTED SENSOR OPTION:	
1) Controller installation	1) Assure that sensors are NOT located near supply registers, windows, heaters, saunas, etc.
2) Air stratification	2) Consider continuous blower operation.

7.6 Pool Water Heating Problems (Water-Cooled Units Only)

NOTE:

1. Water-cooled models include a water proving switch to confirm water flow before the water heating mode can be activated.
2. Lack of water heating may be a symptom of another refrigeration or controls problem not related to the water circuit.
3. Under normal conditions the water temperature rise across the dehumidifier should be between 4° and 15°F.
 - LOW TEMPERATURE INCREASE OF WATER is a symptom of excessive water flow rate. Excessive water flow can erode the water condenser and cause premature equipment failure.
 - HIGH TEMPERATURE INCREASE OF WATER is a symptom of insufficient water flow. This can be caused by an undersized pump, insufficient water diversion or restrictions in the water piping such as dirty filter(s). This would also lead to high refrigerant discharge operating pressures in the water heating mode.

8. Appendix

8.1 Compressor Failure

Although some compressors fail because they are mechanically flawed, most failures are due to system-related problems. Compressor failure can be caused by liquid flood back, air/moisture in the refrigeration system, solid contaminants, excessive heat or electrical service malfunctions. To avoid repeated callbacks, you must determine the cause of the failure and then correct it.

If the compressor has failed because its motor has burned out, the refrigerant, oil, and piping may have become severely contaminated. If a burnout has occurred, use the following procedures to replace the compressor and clean the refrigerant system. Use an oil test kit to determine the severity of the burnout. Make sure you use rubber gloves and eye protection, as contaminated refrigerant and oil can cause severe burns!

WARNING

You must clean the system thoroughly to prevent repeated compressor burnouts.

8.1.1 Compressor Replacement

Desert Aire dehumidifiers are designed with scroll compressors. Scroll compressors are known for operating more reliably than other compressors in air conditioning and dehumidification applications due to their ability to cope with occasional periods of liquid refrigerant return. There are fewer moving parts in a scroll compressor subject to wear compared to alternative compressor designs. Nonetheless, there are still many mechanical and electrical parts with close tolerances. Replacement of the compressor may be required during the normal service life of the dehumidifier.

Inspection and Initial Diagnosis

Generally, the compressor will have two basic failure modes, mechanical or electrical. The compressors are a hermetic design, meaning all components, including the motor, are in a sealed shell. It can be very difficult to determine which issue was the root cause of the failure in the field by inspection of the damaged compressor. For example, an initial bearing failure inside the compressor may create debris that contaminates motor windings. High current draw may be related to a bearing issue or a motor winding issue. The initial inspection must be combined with a final analysis of the machine when returned to working order to confirm diagnosis.

Specific items should be noted before the replacement to give the best indications of the

failure and complete the diagnosis as the new compressor is installed. The following data should be taken to assist in diagnosis:

- Current draw for each leg of power (if the compressor will run and pump).
- High side and low side pressure (if the compressor will run and pump).
- Resistance of each leg to leg on three phase compressor or each leg to neutral on single phase compressors.
- Check of continuity from each leg to ground.
- Review of all system alarms including the relative timing of the alarms and mode of operation.

It is important to note that other components or lines may have been damaged if the compressor has failed. At times the internal damage to a compressor creates extreme levels of vibration before complete failure. Refrigerant lines and connections may be damaged before the compressor stops. Inspect tubing and components of the system before completing the compressor replacement.

Compressor Replacement

- Refrigeration oil must be tested for acid and particulate during any compressor replacement. For the initial testing, the compressor sump should be used to sample the oil. Oil can be recovered through the Schrader port on the low point compressor shell or through the suction line connection after the compressor has been removed.
- Use Virginia KMP, New-Calgon Phase III, Sporlan Test-All, or equivalent oil test where oil is sampled into a container. Vapor sampling methods may not show particulate and should not be used.
- Read the oil test kit manufacturer's instructions to determine if there is acid present in the oil. Determine if there are other contaminants by viewing the samples for darkness, cloudiness, or particulate.
The following procedures must be used depending on the results of the test above:

Any Compressor Service

- A new filter dryer must be installed when the system has been opened. If there is no acid or particulates indicated, the new compressor can be installed and run. Proceed to Testing and Final Diagnosis.

Acid Indicated

- Install a suction line filter shell and charcoal activated core such as a Sporlan or Emerson HH core type or equivalent. The acid levels will be monitored and several core changes may be required. Install ball valves on either side of the suction filter to facilitate these changes. Note that larger Desert Aire systems will have suction filter shells installed from the factory. The shell can be used with charcoal activated cores. Note that a "safety screen" may be required with some manufacturer's cores to prevent small pieces of the core from dislodging and finding their way to the compressor. Follow filter shell and core manufacturer's instructions.
- Review compressor and suction line for area where future oil samples can be taken from the system. If an access fitting exists on the compressor shell below the oil level, no further action is needed. If this is not available, an access fitting can be located at the bottom of a trap in the suction line. Braze in a fitting as required to be able to remove an oil sample.
Note: It is acceptable to use acid test kits that sample the refrigerant and connect to Schrader fittings.
- Ensure there are access fittings directly upstream and downstream of the suction filter. There is typically one fitting installed on the suction filter. There may be a bulkhead fitting attached to the compressor suction side.
- Do not use acid neutralizing additives or other chemicals for acid removal. The refrigeration

system must contain only oil and refrigerant. Precipitates of additives and acids may be considered contamination in the refrigeration system. Other compounds may be present in additives as carriers. Long-term effects of specific additives or compounds with a particular system or design are unknown without significant controlled testing.

Particulate Indicated

- Install a replaceable core liquid line filter shell. Note that larger Desert Aire systems will have replaceable core liquid line filter shells installed from the factory. The pressure drop levels will be monitored and several core changes may be required. Install ball valves on either side of the filter shell to facilitate these changes.
- Install a secondary filter such as Sporlan FS-series or equivalent 20-micron filter in the replaceable core.
- Ensure there are access fittings directly upstream and downstream of the liquid filter. There is typically one fitting installed on the filter shell. There is typically a fitting installed on the outlet side of the receiver.

Returning to Service

- See section 5.5 for evacuation and charging.
- Restart unit and set unit to run compressors.
- Record the pressure drop across the suction filter and liquid line filter dryer.
- Check sight glass indicator for moisture level.
- Monitor pressure drop across the liquid and suction filters during the first hour of operation. Compare the reading taken earlier. If the pressure differential across the filters is 5 PSI or greater, isolate the filters using the valves installed and recover the refrigerant from the filters. Replace cores. If activated carbon filters were installed in the suction side to remove acid, replace with similar cores. If a secondary filter was installed in the liquid line core to remove particulate, install cores and secondary filter in this location.
- Run unit for 24 hours and review acid levels (if found previously) and pressure differentials.
 - If acid is found, replace with activated charcoal cores and test at 24 hour intervals until acids are at acceptable levels. Once acid is no longer detected, replace cores with standard filter elements. Remove outlet screens if they were required by filter manufacturer.
 - If the pressure differential across the liquid line filter is 5 PSI or greater, replace cores and secondary filter with new components and test at 24 hour intervals until pressure drop is at acceptable levels. Once pressure differential is less than 5 PSI, remove secondary filter and replace cores.

Testing and Final Diagnosis

It is of critical importance to ensure that the system is operating as expected before unit is returned to normal service. Complete a LC-LV Series Compressor Replacement Form located in the Installation and Operation Manual. Validation of this report allows for the continued coverage of the compressor under the original warranty.

It is possible that there was an internal defect in the compressor or normal mechanical wear occurred over time. Compressor longevity generally is a function of load, lubrication, electrical input conditions, and temperatures.

The cause for the compressor failure must be identified before unit is placed back into full service. Both the identification of the cause of compressor failure and the proper cleanup of the system must be addressed to avoid repeat compressor damage.

8.2 Recommended Duct Design

You must use proper duct design to ensure that the dehumidifier operates efficiently and without problems. Undersized or restrictive ducts reduce the system airflow, which can cause premature compressor failure. Use the following diagrams as a guide when you design the duct system

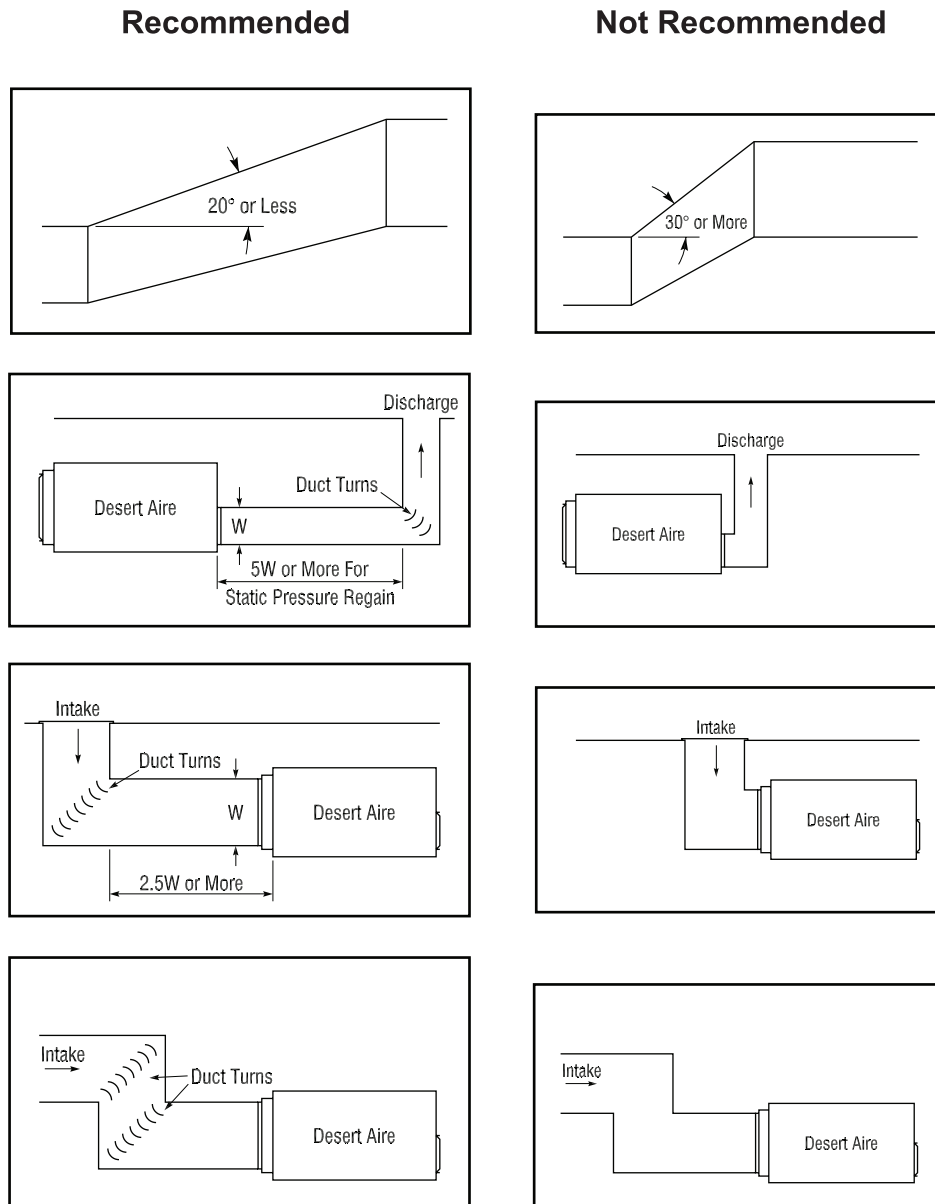

Figure 40: Recommended Duct Designs for Desert Aire Dehumidifiers

8.3 System Guidelines

8.3.1 Recommended Controller Settings

It is important to determine your comfort set points and to avoid further controller adjustments. It takes time for the unit to establish equilibrium at a given set point. Therefore, continued set point adjustments will lead to high energy consumption and user discomfort. Continuous blower operation is recommended. This will reduce air stratification and ensure that the refrigeration circuit is activated only when it is necessary.

RECOMMENDED SET POINTS:

- Humidity 50% to 60% RH
- Air Temperature 2° to 4°F above the pool water temperature

WARNING: Never disable a dehumidifier in a pool / spa room application unless the pool / spa has been drained. Even when a pool / spa is not in use, the pool / spa water continues to evaporate and add moisture to the air. During these periods of high humidity, moisture will seep into walls, ceilings, furniture, etc. Although the dehumidifier may be capable of regaining control of pool / spa room conditions after re-start, moisture damage to the pool / spa room may result from the period when the dehumidifier was disabled.

8.3.2 Refrigeration System Pressures

Many factors affect refrigeration pressures on a given day. Such factors include ambient temperature, water temperature, airflow volume and relative humidity.

Directly measured suction / discharge temperatures will differ due to suction / discharge superheat. However, for the sake of troubleshooting:

- Normal Suction Temperature Range 32° to 40°F
- Normal Discharge Temperature Range 95° to 130°F

8.3.3 Temperature Rise or Drop Across Unit

- Typical air temperature rise across unit (reheat mode) 10° to 15°F
- Typical air temperature drop across unit (air conditioning or water heating mode) is 10° to 15°F

NOTE:

- If your unit does not meet these temperature ranges, check the system airflow
- These guidelines do not apply to dehumidifiers with outdoor air intakes when they are in the “occupied” mode.

8.4 Sequence of Operation

The standard sequence of operation for a Desert Aire dehumidifier is relatively simple. Whenever the compressors run, refrigerant flows through the evaporator coil where it absorbs heat from the warm, humid air stream. This heat must be rejected to one of three heat sinks; room air, pool water, or a separate air stream (remote condenser). The dehumidifier will direct the heat where it is needed (or not wanted) as determined by the controller set points.

8.4.1 Dehumidification and Air Reheat

When the room air requires dehumidification and no cooling is required, the dehumidifier runs in the “reheat” mode. The hot refrigerant is discharged to the reheat condenser which warms the dehumidified air. The air which is discharged from the unit is drier and about 10°F warmer than when it entered.

8.4.2 Dehumidification and Air Cooling

When the room air requires cooling, or dehumidification and cooling, the dehumidifier attempts to run in the air cooling mode. The hot refrigerant must be discharged to a condenser other than the reheat coil. The refrigerant can be discharged to an optional pool water condenser or an optional remote outdoor condenser (if so equipped). The air which is discharged from the unit is drier and about 10°F cooler than when it entered. Should there be no available heat sink (i.e. no remote condenser is equipped and pool water temperature is greater than set point), the unit will not energize the compressors. This prevents the space from significantly overheating. Unit will energize the compressors once the space cools below the cooling set point or a heat sink becomes available.

8.4.3 Cooling and Water Heating (Water Cooled Unit Only)

When the room air requires cooling and the pool water requires heating, a dehumidifier equipped with a pool water condenser will run in the air cooling / pool water heating mode. The hot refrigerant will be discharged to the pool water condenser if the water flow proving switch shows that water is flowing through the condenser. The air which is discharged from the unit is drier and about 10°F cooler than when it entered.

8.4.4 Dehumidification and Water Heating (Water Cooled Units Only)

When the pool water requires heating and the room air requires only dehumidification without cooling, a dehumidifier equipped with a pool water condenser will run in the air reheat mode. This is referred to as “Air Heat Priority” since both the air and the pool water require energy. This is the default setting as the unit is shipped from the factory.

It is possible to set the unit to “Water Heat Priority” to have this mode of operation divert the energy to the pool water rather than the air for reheating. This should be done with caution as there must be sufficient capacity of auxiliary heating to overcome the cooling of the air. If set for Water Heat Priority the air which is discharged from the unit is drier and about 10°F cooler than when it entered even though cooling of the space is not required. Adjustments between “Air Heat Priority” and “Water Heat Priority” can be made through the unit display. Refer to the Controls User Manual for adjustment instructions.

8.4.5 Partial Pool or Spa Water Heating

If the dehumidifier has been equipped with Partial Pool or Spa Water Heating, a portion of the heating energy will be routed to the water when there is a call for water heating and dehumidification or cooling of the space. If the unit is in cooling mode the air which is discharged from the dehumidifier is drier and about 10°F cooler than when it entered. If the unit is in dehumidification mode, the air which is discharged from the dehumidifier is drier and about the same temperature as when it entered.

8.4.6 Operation of Water Condensers and Optional Pump Starts

- The LC and LV units have options for water condensers that heat pool water or reject energy to a water loop. The command for pool water heating is described in the sections above. A water-cooled condenser can also be installed that takes the place of a remote condenser as described in the above sequence. The temperature of the water is not monitored by the controller when the unit is configured with a water-cooled condenser intended for use on a water loop.
- Units containing either pool water heating option or water-cooled condenser option can be configured to create a dry contact closure when water should be flowing through the condenser. If the controller has been configured this way, the contact to the remote pump will close. After flow is established as sensed by the water flow switch, the unit will then shift to the appropriate condenser. Should flow not be established, the unit will shift to the next available condenser having priority. If no other condensers are available, the compressor will not energize (or de-energize if previously operating) until flow is established or requirements change.

- Refer to the Controls User Manual and electrical schematic for instructions on programming pump start command(s) if required.

8.4.7 Blower Operation

Units have been factory wired for continuous blower operation. This helps prevent air stagnation and stratification. Continuous blower operation is also required on units with the return air sensor option. If the blower shuts off, the sensors cannot read the actual room temperature and humidity. Refer to the system wiring diagram and the controller documentation for the possible blower operation options.

8.4.8 Air Heat (Optional)

- LC Only – If so equipped, a standard dehumidifier can activate an internal auxiliary air heater when the room temperature drops below the set point. The supply air blower of the dehumidifier must run whenever there is a demand for air heating. You must verify this when installing an auxiliary heater.
- LV Only – The DHLV series electric duct heaters for LV units are externally mounted to the supply air connection. The heaters are designed to be electrically connected to the dehumidifier for single point power connection.
- The DHLV heater is shipped independently of the dehumidifier. In most cases it is desirable to locate the electric box of the heater on the same side as the dehumidifier electrical panel. The heater has been designed to allow airflow in either direction such that it is possible to position the electric box for the heater on the opposite side, however, the elements of the heater must be located in the “blast” area of the blower. This is the area where the blower wheel is visible.
- Power and control wiring for the electric heater protrudes from the top of the dehumidifier and must be securely connected to the electric heater terminals before providing power to the unit.
- A differential pressure switch is used as a safety interlock for proof of airflow. It is located in the lower section of the LV. It is connected to static pressure sensors using the pressure drop of the reheat condenser of the dehumidifier as proof of airflow. If the airflow drops below the set point, the switch will open and prevent the heater from operating.
- The static pressure sensors also allow an easy way to balance the airflow by using a manometer to measure the static pressure drop of the reheat condenser. Refer to section 3.4 on air balancing for further details regarding the balance procedure. Be sure to replace the heater differential pressure switch tube connections to these sensors when finished to permit heater operation. The higher pressure is between the heat exchangers and the lower pressure is in the blower compartment. The switch has an indication for high and low at the tube ports.

8.4.9 Outdoor Air (Outdoor Air Equipped Models Only)

During the “occupied” mode the dehumidifier will energize the outdoor air damper and exhaust fan terminal contacts. Desert Aire LC and LV Series dehumidifiers will operate in the occupied mode only if the occupancy timer is set accordingly. See Section 6.3 for further outdoor air operation mode details.

8.5 Component Replacement, Charge, Evacuation, & Leak Instructions

Note that a new liquid line filter dryer will be required any time a refrigeration system is opened for servicing. New dryer should be of the same capacity as the original or larger.

Recovery

When there has not been a major refrigeration system leak, the system will contain refrigerant. This refrigerant must be either recovered to separate cylinders appropriate for the refrigerant type or isolated in a portion of the refrigeration system that will not be open for service. In all cases you must comply with Section 608 Refrigerant Recycling Rule of the Clean Air Act.

Recovery of Systems with a Refrigeration System Leak

As much refrigerant as possible must be recovered into separate refrigerant cylinders appropriate for the refrigerant being serviced. System pressure near the leak site should be monitored closely to ensure this area is not pulled to a vacuum. Isolated sections of the system as required and recover independently to avoid refrigerant contamination. Uncontaminated refrigerant can be reused in the refrigeration system it was recovered from.

Recovery of Systems without a Leak

Systems that do not have leaks, but still require refrigeration system service, may have charge isolated in receivers and condensers if these particular components do not require direct service. Desert Aire dehumidifiers have different receiver sizes depending on the model and size. Condenser sizes and configurations may also vary. In general, larger receivers will come equipped with isolation valves that will allow for a portion of the charge to be contained in the receiver during servicing. Units equipped with remote condensers will have isolation valves located inside the unit cabinet near the area where the connections are made.

The compressor can be used to move refrigerant to the system components that will be used to temporarily hold the charge. Note that cooling a condenser by running as many fans as possible and/or cooling the coil surface with a stream of water can assist in storing charge.

The low side pressure should be monitored closely while using this procedure to store charge. Under no circumstances should a compressor be allowed to run in a vacuum. When most of the refrigerant is isolated in the receiver and/or condensers, recover remaining charge into separate refrigerant cylinders appropriate for the refrigerant being serviced. Carefully track the amount of refrigerant charge removed as this exact amount should be placed into the units when re-charging.

Repair / Component Replacement

- If any portion of the system was at a vacuum, place dry nitrogen in the system until atmospheric pressure is reached.
- It is preferred that components are removed by heating the braze alloy to the re-melt temperature and mechanically moving the component. When this is not possible due to proximity of cabinet structure or other components, a tubing cutter can be used to remove sections of piping. Where new tube is required for replacement, use dehydrated tube where possible. Use the same type of fittings as original. Route the pipe in the exact manner as originally routed. Use Type K per ASTM B 88 or ASTM B 819 or Type ACR per ASTM B 280 copper tubing or for all tubes 1 1/8" and smaller.
- Tubes 1 3/8" and larger shall use Type K per ASTM B 88 or ASTM B 819.
- Cap sections of tube and components that are not actively being installed to prevent infiltration of moisture and contaminants.
- Use only braze alloy to join tube.
 - The selection of filler metals is highly dependent on the tube fit, clearance, and operator preference for flow. When flux is to be used, care should be taken to ensure that the flux is not introduced to the inside of the tube. It is recommended that phosphorous bearing alloys be considered for copper-to-copper connections due to their self-fluxing on copper-to-copper joints. Refer to alloy manufacturer's guidelines for details on compatibility.
- Flow nitrogen into tubing to prevent the formation of copper oxides.
 - Copper oxides form rapidly when copper is heated to temperatures required by the brazing process and exposed to oxygen in the air. Copper oxides flake easily on the inside of the tubing and dislodge easily when the system is filled with refrigerant and oil. The particulate can move throughout the system and cause contamination on valves and other critical components. System filters may become fouled.
 - Flowing nitrogen into the system and ensuring that the inside of the tube is significantly free from oxygen while brazing ensures that oxides do not form. As the last joints of a system are made, additional thought must be made on the location where the nitrogen can escape. Schrader valves are placed throughout the system. These valves can be opened to allow for nitrogen to flow without generating pressure behind the braze joint that is being created.

See Section 8.1.1 for special procedures related to compressor replacements.

- Replace liquid line filter dryer as last step in system repair. Note that the dryer will readily absorb moisture from the ambient air and must be open only for as long as required for installation.
- After completion of all repairs, pressure test system using nitrogen pressure decay test or nitrogen with tracer gas and appropriate leak detector.

Evacuation

- Carefully inspect pump and related equipment before connecting to system.
- Ensuring gaskets are in good condition and pump is capable of low vacuum levels can save time. Connect pump(s) to as many locations as possible ensuring all locations are well sealed. Recommended recovery / evacuation points are at each condenser, and both sides of the compressor. If a field charge will be required, connecting a refrigerant tank to the system with a good valve is recommended. Any hose connections requiring purging of non-condensable can be done at this point.
- Evacuate the line and remote condenser to 400 microns measured at a point on the system furthest away from the pump.
- Note that a gauge installed on the pump or in close proximity will give a lower reading while the unit is being evacuated.
- A deep vacuum gauge should be used to evaluate the pressure. Compound manifold gauges do not allow for enough accuracy at the pressures required.
- The system should be able to hold a vacuum under 500 microns for more than 10 minutes.
- If pressure continuously rises at a rapid rate there is likely a system leak. Review all piping connections and correct before continuing evacuation.
- Pressure rising above 500 microns and tending to stabilize at a higher pressure indicates the system has moisture above specifications. Continue evacuation until 500 microns or lower can be held for a minimum of 10 minutes.

Alternative Evacuation Specified by Process

After components have been repaired or replaced evacuation procedure should take place. Very small amounts of refrigerant may still be mixed with the oil in the system. Out-gassing of this refrigerant may interfere with the evacuation and vacuum decay testing.

IF, AND ONLY IF, a unit has been previously charged with refrigerant, and standard evacuation method has not been successful after 24 hours minimum using the standard procedure, the following alternative method should be used.

- Check vacuum level. It should be a maximum of 1,500 microns absolute pressure. If this is not the case, review system for leaks and continue evacuation process until 1,500 microns is achieved.
- Purge system with nitrogen to atmospheric pressure (0-gauge pressure). Ensure all portions of systems are at this pressure. Seal system and wait 10 minutes. Start vacuum pump and draw system to 1,500 microns or less.
- Purge system with nitrogen to atmospheric pressure (0-gauge pressure). Ensure all portions of systems are at this pressure. Seal system and wait 10 minutes.
- Start vacuum pump and draw system to 500 microns. Seal system. System may rise to a higher level, but should not rise above 1000 microns in a 10-minute timeframe. If unsuccessful, continue evacuation or check for leaks.

It is anticipated that the system was clean and tight from the original process and refrigerant only is mixed with oil. Alternative process should not be considered if there is chance of free water entering the system or the system was open for any significant time.

Charging

- Charge should be weighed into the system using a scale. In cases where the full charge was recovered, weigh in the charge with the recovered refrigerant and add the appropriate amount to meet the rating plate and field charge (if applicable). This should be placed in the high side of the system at the receiver.

- In cases where the full charge cannot be added to the system high side, the charge can be added to the low side of the system only when compressors are energized. If this is required, the compressors should be energized and the charge should be slowly metered into the suction line as far as possible upstream of the compressor. If the unit is equipped with an accumulator, the charge needs to be added to the port upstream of this location. The bulkhead fittings on the side of the unit should not be used for charge addition. Monitor superheat at the compressor suction inlet using the bulkhead fitting and a temperature sensor on the suction line near the compressor. Superheat should not drop below 10 degrees during the process of adding charge.

Testing and Final Diagnosis

Check the oil level in the compressor after the system has been running for 24 hours. Oil may have been contained in the liquid refrigerant when recovered from the system. Most of this oil will be returned if the recovered refrigerant is used. If new refrigerant is added, additional oil should be added based on the following ratio:

New Refrigerant Charge Added, lbs. x 0.352 = Oil charge, oz.

It is of critical importance to ensure that the system is operating as expected before unit is returned to normal service. Test component replaced and function of the system. Many times a separate component in the system may have set a condition that causes a failure of another. Thoroughly test systems to ensure repeat failures do not occur.

Note: Compressors supplied with an oil sight glass should be viewed and filled to 75% capacity.

8.6 Rating Plate

The system rating plate is attached near the electrical enclosure of the dehumidifier.

 Model No: XXXXXXXXXXX-XXXXXXX Serial No: 2224E32001			Max. Ambient Temperature:		48.9°C (120°F)		
			Voltage/Phase/Hz:		460/3~/60		
Unit Tag #: DHU-1			Control Voltage:		24 Volts		
For Outdoor Use, IPX4			Min Ampacity:		65 Amps		
			Max Overcurrent Protective Device:		80 Amps		
			Minimum Disconnect Current Rating:		70 Amps		
SCCR: 65kA rms symmetrical, at nameplate voltage maximum							
Compressors			Supply Blower(s)			Transformers	
Mtr #	RLA	LRA	Qty	HP	FLA	Xfmr #	VA
2	17.9	125.0	1	15	18.5	1	150
3	17.9	125.0	Exhaust Blower(s)			2	250
4	N/A	N/A	Qty	HP	FLA	3	N/A
5	N/A	N/A	1	3	4.3	4	N/A
Condenser Fans			Maximum Allowable Pressure			5	N/A
Qty	HP	FLA	Low Side	1.72 Mpa (250 psig)		6	N/A
0	0	0.0	High Side	4.5 MPa (650 psig)		7	N/A
Heat Wheel Motor			R-454B Factory Charge			Electric Heater	
Mtr #	HP	FLA	Circuit A	32 kg (72 lbs)		kW	N/A
11	0.25	0.8	Circuit B	N/A		FLA	N/A
Motors powered by VFDs or 3Ph transformers use line-side current for MCA/MOPD calculation. Load side FLA shown.				Wiring Diagrams			
Maximum operating water pressure 225 psig Minimum operating water pressure 0 psig				HIAQ3-32FNVN, , LIAQ3-1A, LIAQ3-2D, LIAQ3-3A, LIAQ3-4A, , HT-1			
For Installation Only in Locations Not Accessible to the General Public				Independent Powered Electric Heater			
This product may be covered by one or more patents. www.desert-aire.com/markings				Voltage/Phase/Hz: N/A			
Desert Aire LLC - N120 W18485 Freistadt Rd. Germantown, WI 53022 P: (262)946-7400 F: (262)946-7401				Control Voltage: N/A			
				Min Ampacity: N/A			
				MOPD: N/A			

Figure 41: System Rating Plate

8.7 Start-up Supervision Supplemental Information (Optional)

A Desert Aire factory start-up is an option as well as CST or Remote Start-up Assistance which can be purchased with the equipment. A factory start-up includes several key services: The expertise of an accomplished, factory-trained technician who will supervise the commissioning of the equipment.

- The Desert Aire representative will assist the installing contractor with filling out the Start-up Report.
- He will also inspect the installation to make sure that the dehumidifier has been properly integrated with the rest of the equipment on the jobsite.
- Finally, he can train the maintenance personnel to operate and service the equipment if necessary.
- A factory start-up does not include installation assistance. The installing contractor is responsible for ensuring that the system is ready for start-up when the Desert Aire technician arrives.
- When the installing contractor is confident the system will be ready, they should contact the Desert Aire Sales representative to schedule the start-up. Please call at least two weeks before the desired start-up date to help prevent scheduling conflicts.

8.8 System Start-up Report

A copy of the system “Start-up Report” can be found on the following page. This report needs to be filled out thoroughly by a qualified service technician and returned to Desert Aire for warranty validation. Please ensure that the model and serial number of the unit are noted on this form. The model and serial number can be found on the system’s rating plate located on or near the electrical compartment service door. Failure to complete and return this form will void the unit’s warranty. These reports are also helpful when trying to correct existing problems. Should you need system diagnosis help, email the completed worksheet to Desert Aire’s Service Department using the email address provided. Be sure to include your name and telephone number where you can be reached.

LC/LCQ/LV Start-up Request Form



Factory Assisted Start-up consists of a Desert Aire Service Department Technician to visit the jobsite and provide **supervisory** experience to installing contractors as they perform the required procedures as outlined in our warranty activation start-up report. The company technician will also present an educational review of the dehumidifier's operating and maintenance requirements. **Factory Assisted Start-up is not an installation bid and therefore the system must be ready to run before scheduling.**

CST Start-up is performed by a local Certified Service Technician who has been trained by Desert Aire. The CST performs all duties listed above. In addition, they will supply the "items to be supplied for start-up" as listed below. Please note charges for refrigerant will apply if refrigerant is necessary to complete the start up.

Remote Assisted Start-up – Refer to Remote Start-up Request Form.

Prior to scheduling start-up with Desert Aire, the site must be fully prepared for commissioning with the following items completed.

Items to be completed by the installing contractor before any Start-up can be scheduled:

- Dehumidifier leak checked and inspected for internal concealed damage. Remove access panels and inspect the interior of the unit for transit damage. Contact Desert Aire immediately if damage is noted. **(262) 946-7400**
- Remove shipping blocks from under the compressor.
- Pool filled with water and heated to 80°F and 75°F air temp
- Dehumidifier leveled and properly supported per the installation manuals recommendations. **See section 5.1 of the LC/LV I&O manual for details**
- Return and supply duct work complete with grills, registers, and turning veins installed where necessary.
- Outside air duct, filters and damper installed (if applicable) – **See LC/LV I&O manual section 5.2 for details**
- Condensate P-Trap installed with heat trace for winter operation. **See LC/LV I&O manual section 5.3 for details**
- Remote condenser plumbed per **Air Cooled I&O manual section 5.5**, Traps installed at the base of all hot gas risers and check valve installed in the hot gas discharge line as close to the remote condenser header as possible.
- Refrigeration line set is clamped and the header supported per the **Air Cooled I&O manual sec 5.3**
- Lineset and remote condenser leak checked, evacuated, and charged if necessary. All units require additional field charging. **Refer to the charge label affixed to the unit for details.** Refrigerant added _____lbs. (R-454B)
- All electrical connections terminated and verified for proper voltage at the unit and the condenser (if applicable).
- Units ordered with room mounted T/RH sensors will have a sensor, cable and housing shipped loose in the electrical compartment of the dehumidifier. **See LC/LV I&O manual section 5.8 for details.** Units ordered with return air sensors will be pre-installed by the factory.
- Water condenser circuit connected to dehumidifier with flow meter and balancing valves installed in circuit. Water flow verified and air purged from water the lines. (if applicable)
- Water temperature sensor wells and temp sensors installed and wired per **I&O manual section 5.4** (These sensors and wells are shipped loose in the electrical compartment of the dehumidifier if the unit has a water heating circuit.)
- Gas heater lines plumbed and purged. Record gas pressure entering the unit. _____'wc (if applicable)

Items to be supplied by the installing contractor (Factory Assisted or Remote Assisted Start-up only)

- Equipped service vehicle and service technician – Technician will be trained.
- Volt/Amp/OHM meters. / Refrigerant Manifold Gauges (R-454B)
- Air balancing equipment (magnehelic or manometer differential pressure gauge – one inch scale preferred)
- 50# of the appropriate refrigerant and scale (R-454B)
- Hand pump for adding oil to compressors and 1 gallon of one of the following oils:

Copeland® Ultra 32-3MAF Hatcol 22 CC

Lubrizol Emkarate RL 32-3MAF Copeland® Ultra 22 CC

Parker Emkarate RL 32-3MAF Mobil Arctic 22 CC

Nu Calgon 4314-66 (RL 32-3MAF)

(This is required on split systems based on line set calculations and trapping)

LC/LCQ/LV Start-up Request Form



Unit Information Model # _____
Serial # _____

Jobsite Information Job site name: _____
Job Site Address: _____

Installing Contractor:

Manager's Name: _____ Phone #: _____

Job Site Contact: _____ Cell #: _____

Controls Company Name: _____

Controls Contact: _____ Cell #: _____

Test and Balance Company:

If you are unable to supply any of the required equipment you must contact Desert Aire before returning this document.

I agree that all of the above has been completed as of _____ (Date) If a return trip must be scheduled due to insufficient job-site preparation an additional purchase order must be issued to Desert Aire for re-scheduling. **A two-week minimum is needed to schedule start-up.** Once the form is completed, please Email both pages to the Desert Aire service department. startup@desert-aire.com

Signature of project manager: _____ (print) _____ (sign)

Company Name: _____ Phone #: _____



LC/LCQ/LV AireGuard™ Remote Start-up Assistance

AireGuard Assisted Start-up consists of a Desert Aire factory technician remotely assisting a job-site technician to complete the commissioning process of the dehumidifier. Using a field installed Ethernet connection, Desert Aire will be able to navigate the controller and verify critical set up details to ensure proper equipment operation. The field technician will work under the guidance of Desert Aire to make any mechanical adjustments identified by Desert Aire to complete the commissioning process.

Prior to scheduling start-up with Desert Aire, the site must be fully prepared for commissioning with the following items completed.

Job Site Preparation - Items completed by the installing contractor before Start-up can be scheduled:
Items to be completed by the installing contractor before any Start-up can be scheduled:

- Dehumidifier leak checked and inspected for internal concealed damage – remove access panels and inspect the interior of the unit for transit damage. Contact Desert Aire immediately if damage is noted **(262)946-7400**
- Dehumidifier leveled and properly supported per the installation manuals recommendations. **See section 5.1 of the LC/LV I&O manual for details.**
- Remote condenser plumbed per **Air Cooled I&O manual section 5.5**, Traps installed at the base of all hot gas risers and check valve installed in the hot gas discharge line as close to the remote condenser header as possible.
- Refrigeration line set is clamped and the header supported per the **Air Cooled &O manual sec 5.3**

- Lineset and remote condenser leak checked, evacuated, and charged if necessary. All units require additional field charging. **Refer to the charge label affixed to the unit for details.** Refrigerant added _____lbs. (R454B)
- All electrical connections terminated and verified for proper voltage at the Dehumidifier and the Remote Condenser (if applicable)
- Temperature / RH sensors – (wall mount applications only) installed per the **LC/LV I&O manual Section 5.8**
- Optional Water Condenser circuit connected to dehumidifier with flow meter, balancing valves and temperature sensors installed in circuit.
- Remove shipping blocks from compressors and blowers.
- Ethernet Connection – Verify the RJ-45 Ethernet connection is installed and active. Contact Desert Aire to verify the connection. **(262)946-7400**
- Photo Document the ductwork and refrigerant line sets used for the remote condensers, be specific with photos showing oil recovery traps and the method of securing the refrigerant lines.
- Pool filled with water and heated to 80°F and 75°F air temp
- Gas heater lines plumbed and purged. Record gas pressure entering the unit. _____'wc (if applicable)

Tool Requirements – These items are required to make adjustments to the system

- Volt/Amp/OHM meters. / Refrigerant Manifold Gauges (R454B)
- Hand Tools – Refrigeration Service Wrenches, Allen Wrenches, Assorted Screwdrivers & Crescent Wrenches
- Air Balancing Equipment (Magnehelic or Manometer differential pressure gauge – one inch scale is preferred)
- 25 # cylinder of the appropriate refrigerant & scale. (R-454B)
- Hand pump for adding oil to compressors and 1 gallon of one of the following POE oils:
 - Copeland® Ultra 32-3MAF Hatcol 22 CC
 - Lubrizol Emkarate RL 32-3MAF Copeland® Ultra 22 CC
 - Parker Emkarate RL 32-3MAF Mobil Arctic 22 CC
 - Nu Calgon 4314-66 (RL 32-3MAF)*(This is required on split systems based on line set calculations and trapping)*

LC/LCQ/LV AireGuard™ Remote Start-up Assistance



Unit Information Model # _____
Serial # _____

Jobsite Information Job site name: _____
Job Site Address: _____

Contractor Information:

Installing Contractor: _____

Manager's Name: _____ Phone #: _____

Field Technician's Name: _____ Cell #: _____

If you are unable to supply any of the required equipment you must contact Desert Aire before returning this document.

I agree that the items listed above have been completed as of _____ (Date)

Once this form is completed, please email both pages to the Desert Aire Service Department.
Email: startup@desert-aire.com

Desert Aire will schedule an appointment within 7 Business Days to commission the unit and will contact the Field Technician directly. The Field Technician will be expected to be onsite at the scheduled time to begin the commissioning process.

If rescheduling is required – Please contact Desert Aire immediately for availability

Signature of project manager: _____ (print) _____ (sign)

Company Name: _____ Phone #: _____



LC/LCQ/LV Start-up Report

Important – To ensure warranty validation and continued customer satisfaction, complete this form and return it to Desert Aire immediately after start-up. Validation of this report activates the warranty.

COMPANY: Desert Aire LLC
DEPARTMENT: Service Manager
ADDRESS: N120 W18485 Freistadt Road Germantown, WI 53022
OFFICE: (262) 946-7400
EMAIL: service@desert-aire.com

Instructions

- Warning - Only trained, qualified personnel should install and service Desert Aire equipment. Serious Injury or death can result from improper handling of this equipment. High voltage electrical components and refrigeration under pressure are present.
- Before continuing, read the Installation and Operations manual. If you do not fully understand the manual contact the Desert Aire Service Department. Please be prepared with the model and serial numbers located on the rating plate of the unit.
- Use one start up report per unit. Print or type all information. If there is not enough space available for readings or comments please attach additional pages directly to the start-up report.

Location and Unit Information			
Installation Name:		Date:	
Installation Address:			
Dehumidifier Model #:		Serial #:	
Remote Condenser Model #:		Serial #:	
Form Completed By (Print):		Signed:	
Company Name:		Phone #:	
Company Address:			

Proper Installation Checklist - Refer to the LC/LV I&O manual for items label "Sec"					
<input type="checkbox"/>	Installation manual read and understood	<input type="checkbox"/>	Tighten all field and factory wiring	<input type="checkbox"/>	Open all refrigeration service valves and tighten packing nuts
<input type="checkbox"/>	Dehumidifier installed and leveled properly. Sec 5.1	<input type="checkbox"/>	Adjust and tighten blower belts if necessary. Sec 6.1	<input type="checkbox"/>	Check field and factory piping for leaks
<input type="checkbox"/>	Condensate drain tapped and primed. Sec 5.3	<input type="checkbox"/>	Check rotation of blower on 3-phase units	<input type="checkbox"/>	Inspect air filters. Clean or replace as necessary
<input type="checkbox"/>	Verify that the power supply matches the rating plate	<input type="checkbox"/>	Check rotation of remote condenser fans	<input type="checkbox"/>	120-volt circuit run to heat trace and powered up - Pool Water Circuit Only

Unit Power Supply – Wire transformers 240 volt for 240-volt applications. Unit leaves factory wired 208 or 460			
Voltage at power block - No motors running	L1-L2	L2-L3	L1-L3
Control Voltage - No motors running	Transformer 1		VA Rating

Line-set Installation*See label affixed to the unit for pipe sizes, charge and additional oil charge. See sections 5.3 and 5.5 of the Air Cooled I&O for pipe design, support and trapping details					
Line Sizes	Hot Gas		Liquid Return		
Lineset Length	Elevation Change		Above Level Below		
Hot gas line trapped at every riser	Inverted traps at top of risers		<input type="checkbox"/> Yes	<input type="checkbox"/> No	<input type="checkbox"/> N/A
Check valve installed	Line-set Clamped per I/O Manual		<input type="checkbox"/> Yes	<input type="checkbox"/> No	<input type="checkbox"/> N/A
Additional R454B Added	LBS	Additional Oil Added	OZS	Oil Traps Primed	<input type="checkbox"/> Yes <input type="checkbox"/> No

Fan Cycle Controller Settings* See sec 7.1.2 of the Air Cooled I&O manual for default condenser pressure setpoints.			
Voltage	L1-L2	L2-L3	L1-L3
Amps - Motor 1	L1	L2	L3
Amps - Motor 2	L1	L2	L3
Discharge Pressure Setpoint			

*Denotes that this is a model dependent item

Air Flow Readings: See Sec 6.3.3 of the LC/LV I&O manual for airflow instruction and specs					
		Unoccupied Mode		Occupied Mode*	
Evaporator Static Pressure Drop		"Wc		"Wc	
Reheat Condenser Static Pressure Drop		"Wc		"Wc	
Supply Duct Static Pressure		"Wc			
Return Duct Static Pressure		"Wc			
OA Damper Setpoint		%			
Blower FLA (off nameplate)	amps	Actual	L1	L2	L3

Temperature Readings- Testing should be done with at a minimum of 70°F			
Room Air Temperature	°F	Room Relative Humidity	%
Outdoor Air Temperature	°F	Outdoor Relative Humidity	%
Water Temp (main pool)	°F	Water temp (spa or other)*	°F

Compressors and Refrigeration in Reheat Mode- Superheat values can be found using the Carel display module and navigating to the analog output page. See section 6.5 Table 20 for proper superheat values. Sub cooling pressure and temp readings are taken between the receiver outlet and the liquid filter.							
Motor #	(6-10 Ton Single Phase Only)						
Compressor RLA off nameplate	amps	amps					
Amperage	L1	L1					
	L2	L2					
	L3	L3					
Head Pressure					Psig		
Suction Pressure					Psig		
Refrigerant Sight Glass Clear	<input type="checkbox"/> Yes	<input type="checkbox"/> No	Oil Sight Glass	<input type="checkbox"/> N/A	<input type="checkbox"/> 1/2	<input type="checkbox"/> 3/4	<input type="checkbox"/> F
Suction temp / Superheat					°F / °F		
Liquid Temp / Sub-cooling					°F / °F		

Compressors and Refrigeration in Pool Water Heating Mode* - See section 5.4.1 of the LC/LV I&O manual for pool water setup and specs. Note information in section 7.6			
Head Pressure	Psig	Suction Pressure	Psig
Water Inlet Temperature	°F	Water Outlet Temperature	°F
Suction temp/Superheat	°F / °F		

Compressors and Refrigeration in Cooling Mode* *Superheat values can be found using the Carel display module and navigating to the analog output page. See section 6.5 Table 20 for proper superheat values. Sub cooling pressure and temp readings are taken between the receiver outlet and the liquid filter.*

Head Pressure	Psig	Suction Pressure	Psig
Refrigerant Sight Glass Clear	<input type="checkbox"/> Yes <input type="checkbox"/> No	Oil Sight Glass	<input type="checkbox"/> N/A <input type="checkbox"/> 1/2 <input type="checkbox"/> 3/4 <input type="checkbox"/> F
Suction temp / Superheat	°F / °F	Liquid Temp / Sub-cooling	°F / °F

Auxiliary Water / Steam Coil Information*

	Signal	Inlet Temp	Outlet Temp	Discharge Air Temp
Water Coil	°F	°F	°F	°F

Auxiliary Electric Heater Information*

	Signal	L1 Amps	L2 Amps	Discharge Air Temp
Electric Heater				°F

Gas Heater Information*

Gas Heater Model #:		Serial #:	
Gas Inlet Pressure	Psig	Supply Air Temp at 100% Signal	°F

Additional Comments:



N120 W18485 Freistadt Road, Germantown, WI 53022 (262)946-7400
 This completed form must be submitted for compressor warranty credit consideration.
 Remit to: service@desert-aire.com

**LC/LV Compressor Replacement Form
 Location and Unit Information**

Installation Name:			
Dehumidifier Model #:		Serial #:	
Form Completed By (Print):		Signed:	
Company Name:		Date:	
Company Address:		Phone #:	
		Fax #:	
		Serial #:	
(If Tandem Set – Only list the specific failed compressor)			
New Compressor Model #:		Serial #:	
Refrigerant Used: (Circle One)	R22	R407C	R410A R454B Other: _____

Compressor Condition at Time of Initial Review

Continuity (0 resistance) to Ground on one or more legs	<input type="checkbox"/>	Compressor drawing higher current than design	<input type="checkbox"/>
Continuity (0 resistance) between two or more legs (3 phase units)	<input type="checkbox"/>	Compressor drawing locked rotor current	<input type="checkbox"/>
Other (describe):	<input type="checkbox"/>	Runs without pumping: Pressures: ____ / ____	<input type="checkbox"/>

Continuity (0 resistance) to Ground on one or more legs	<input type="checkbox"/>	Compressor drawing higher current than design	<input type="checkbox"/>
Continuity (0 resistance) between two or more legs (3 phase units)	<input type="checkbox"/>	Compressor drawing locked rotor current	<input type="checkbox"/>
Other (describe):	<input type="checkbox"/>	Runs without pumping: Pressures: ____ / ____	<input type="checkbox"/>

Liquid Floodback	<input type="checkbox"/>	Low Superheat	<input type="checkbox"/>	Debris	<input type="checkbox"/>	Defective Expansion Valve	<input type="checkbox"/>
Low Sump Oil	<input type="checkbox"/>	Insufficient Motor Cooling	<input type="checkbox"/>	Defective CC Heater	<input type="checkbox"/>	Other (Describe):	<input type="checkbox"/>

Diagnostic/Corrective Action Summary

Describe what corrective action was taken to prevent a repeat failure.

Compressor Replacement Comments/Checklist

- Generally, compressors will have two basic failure modes, mechanical or electrical. Refrigeration oil must be tested for acid particulate during any compressor replacement. Oil can be recovered through the Schrader port on the low point of the compressor or through the suction line connection after the compressor has been removed.
- A new filter dryer must be installed whenever changing a compressor. If the oil is acidic, HH filters will be required to assist in the cleanup. Acid levels must be monitored and several filter core changes may be required.
- Please refer to the installation and operations manual for the detailed compressor replacement cleanup process.

Required			Choose One			For Results of Acid or Particulate			
Acid & particulate test completed	<input type="checkbox"/>		Unit Evacuated to 500 microns absolute & vacuum decay passed	<input type="checkbox"/>		HH / Acid Core Used	<input type="checkbox"/>	Pressure Drop	PSIG
LL Filter Replaced	<input type="checkbox"/>	Pressure Drop	PSIG	Alternate triple evacuation process used	<input type="checkbox"/>	SF Filter Used	<input type="checkbox"/>	Pressure Drop	PSIG

Air Flow Readings: Refer to Installation and Operations manual for correct balancing procedures.

Evaporator Static Pressure Drop	"wc	Supply Duct Static Pressure Drop	"wc
Reheat Condenser Static Pressure Drop	"wc	Return Duct Static Pressure Drop	"wc

Temperature Readings

Room Air Temperature	°F	Supply Duct Static Pressure Drop	°F	Room Relative Humidity	%
Outdoor Air Temperature	°F	Return Duct Static Pressure Drop	°F		%

Compressors and Refrigeration in Reheat Mode

	Cir A – Use both sides for tandem set			Cir B – Use both sides for tandem set		
Motor # (See wiring schematic for details)						
Discharge Pressure	PSIG			PSIG		
Liquid Line Pressure (At access fitting nearest TXV)	PSIG			PSIG		
Suction Pressure (At compressor)	PSIG			PSIG		
Liquid Line Temperature (At access fitting nearest TXV)	°F			°F		
Suction Temperature (At Compressor)	°F			°F		
Refrig. Sight Glass Cond. (Clear, Intermittent Vapor, Flashing)						
Comp. Oil Level Sight Glass (Shut down comps., wait 5 minutes)	1/2 3/4 F			1/2 3/4 F		

Compressors and Refrigeration in Reheat Mode

	Cir A – Use both sides for tandem set			Cir B – Use both sides for tandem set		
Motor # (See wiring schematic for details)						
Discharge Pressure	PSIG			PSIG		
Liquid Line Pressure (At access fitting nearest TXV)	PSIG			PSIG		
Suction Pressure (At compressor)	PSIG			PSIG		
Liquid Line Temperature (At access fitting nearest TXV)	°F			°F		
Suction Temperature (At Compressor)	°F			°F		
Refrig. Sight Glass Cond. (Clear, Intermittent Vapor, Flashing)						
Comp. Oil Level Sight Glass (Shut down comps., wait 5 minutes)	1/2 3/4 F			1/2 3/4 F		



OPTIMIZING SOLUTIONS THROUGH SUPERIOR DEHUMIDIFICATION TECHNOLOGY

N120 W18485 Freistadt Road • Germantown, WI 53022 • E-mail: info@desert-aire.com

Ph: (262) 946-7400 • Fax: (262) 946-7401 • Website: www.desert-aire.com