

CONDENSER SERVICE VIEW ② ⑥ ⑦

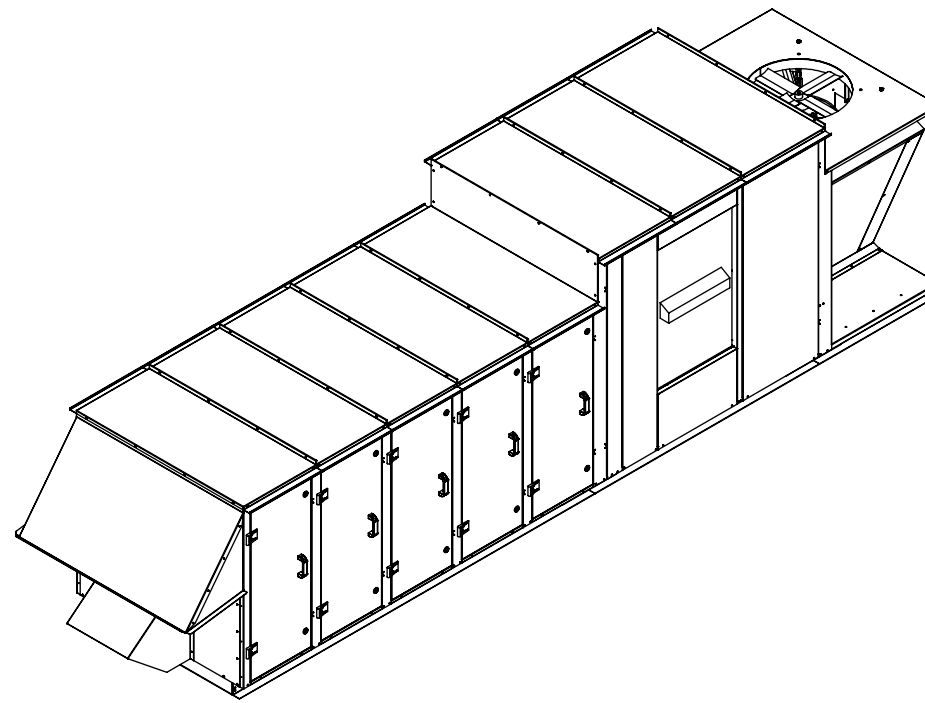

AIR FLOW	UNIT SIZE (TONS)	UNIT CABINET SIZES	GAS HEATER QTY.	L1	W1	H1	L2	W2
DOWN FLOW	05	44-H	1	242 5/8	54 1/2	62 1/8	261	60 1/2
	08	50-H	1	249	61 1/8	70 1/8	272 3/8	67 1/8
	10	60-H	1	267 1/8	72 1/2	81 3/8	290 1/2	78 1/2
			2	301 3/4	72 1/2	81 3/8	325 1/8	78 1/2
	15	72-H	1	279 5/8	87 1/2	83 3/8	308	93 1/2
			2	314 1/4	87 1/2	83 3/8	342 5/8	93 1/2
	20	78-H	1	319 5/8	90 1/2	92 5/8	348 1/2	96 1/2
			2	354 1/4	90 1/2	92 5/8	383 1/8	96 1/2
	25		1	319 5/8	90 1/2	92 5/8	348 1/2	96 1/2
			2	354 1/4	90 1/2	92 5/8	383 1/8	96 1/2
	30	78-H	1	319 5/8	90 1/2	92 5/8	348 1/2	96 1/2
			2	354 1/4	90 1/2	92 5/8	383 1/8	96 1/2

O/A INTAKE / EXHAUST VIEW ② ⑥ ⑦

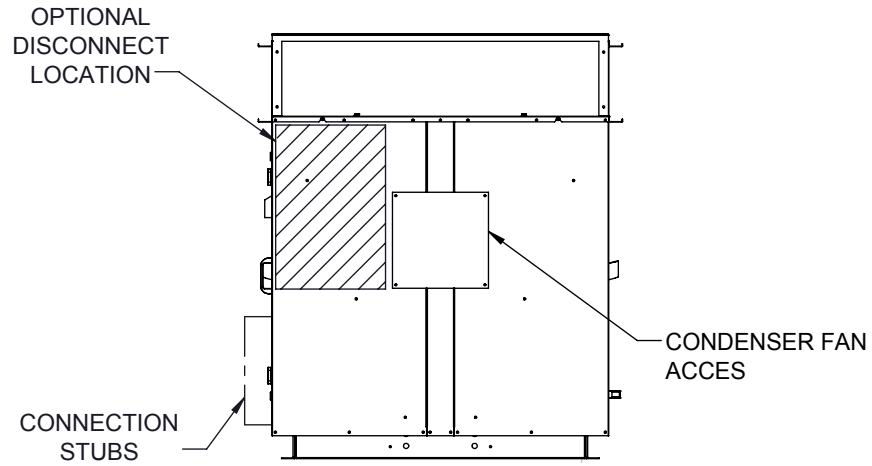
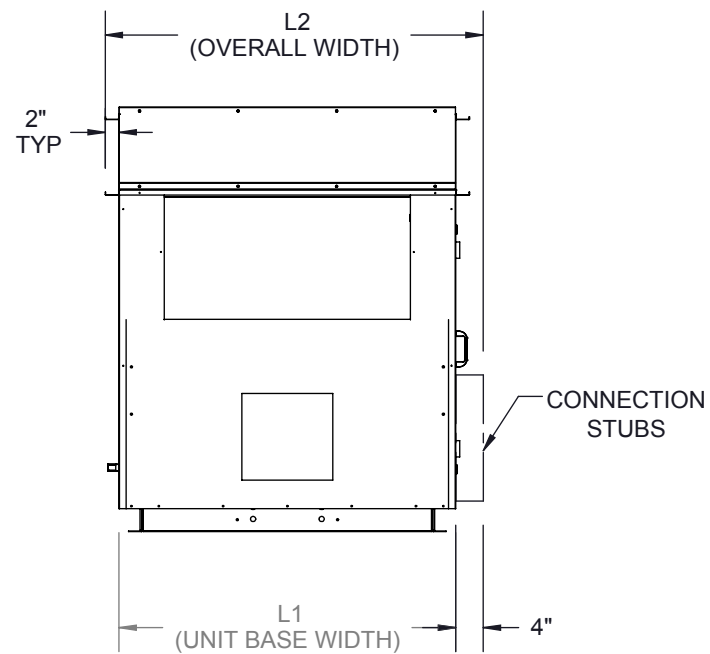

ACCESS SIDE VIEW ⑥ ⑦

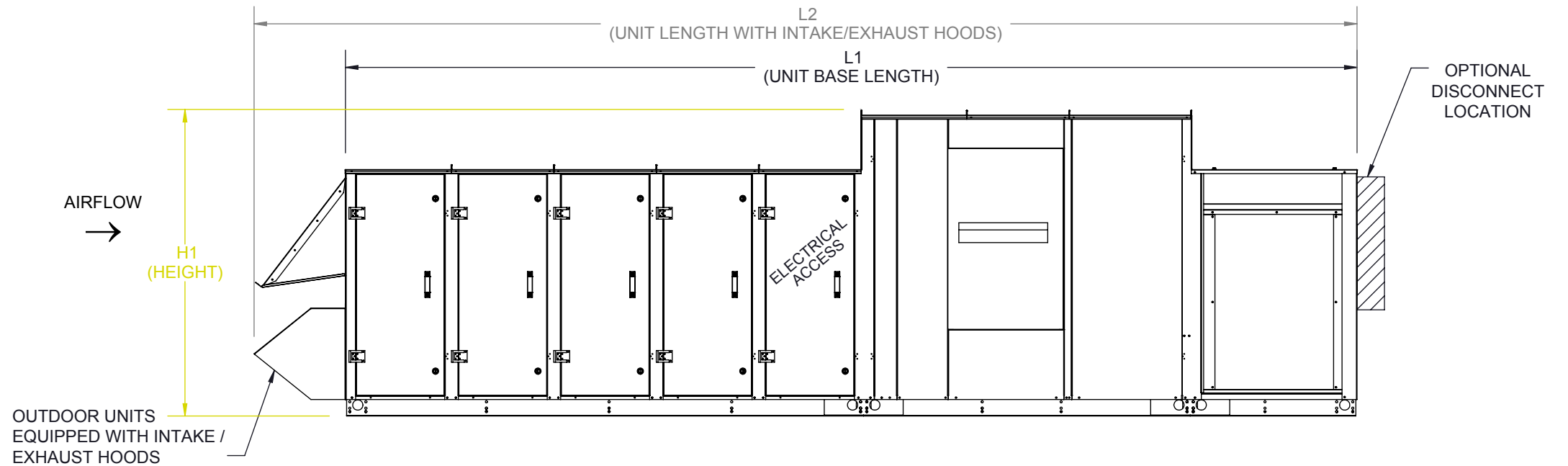

GENERAL NOTES AS REFERENCED BY INDIVIDUAL SHEETS:

- ① PORTION OF SECTIONED OR DETAILED DRAWING HAS BEEN OMITTED FOR CLARITY.
- ② HOODS OMITTED FOR CLARITY.
- ③ VIEW IS FOR PICTORAL PURPOSES. REFER TO PAGE 1 FOR UNIT TYPE SPECIFIC VIEW.
- ④ REFER TO SUBMITTAL FOR CUSTOMER CONNECTION LOCATIONS.
- ⑤ DIMENSIONS ARE TO ACCESS SIDE OF UNIT.
- ⑥ RH ACCESS SHOWN FOR DISPLAY PURPOSES. ACCESS DOOR CONFIGURATION MAY CHANGE DEPENDING ON UNIT SIZE.
- ⑦ REFER TO SHEET 3,4, FOR INTAKE AND DISCHARGE CONNECTION DIMENSIONS.

Desert Aire has a policy of continuous product and quality improvement. Specifications and dimensions are subject to change without notice. This drawing and information contained herein are the exclusive property of the Desert Aire Corporation. Any use detrimental to the interests of Desert Aire is prohibited.

All Dimensions in Inches
All Angles 90°
All outside corners 0.125" fillet
Unless Otherwise Specified

Tolerance Unless Otherwise Specified
X.X ±.125
X.XX ±.060
X.XXX ±.030
Angles ±1°

DESERT AIRE
N120 W18485 FREISTADT RD
GERMANTOWN, WI 53022
Tel: (262) 946-7400
Fax: (262) 946-7401



Third Angle Projection

Part weight

Drawn	Date Released	Description
BCL	5/20/2011	PKGD w/WHEEL & GAS HEAT
Sheet	1/4	Page Title
		GENERAL ARRANGEMENT
Scale	Rev.	Drawing Number
NTS	3	G805-017

ALL DIMENSIONS ARE IN INCHES
FRACTIONAL TOLERANCE ± 1/8"

NOTES:
REFER TO SHEET 1 FOR GENERAL NOTES.

SIDE CUSTOMER CONNECTIONS ③ ④ ⑥

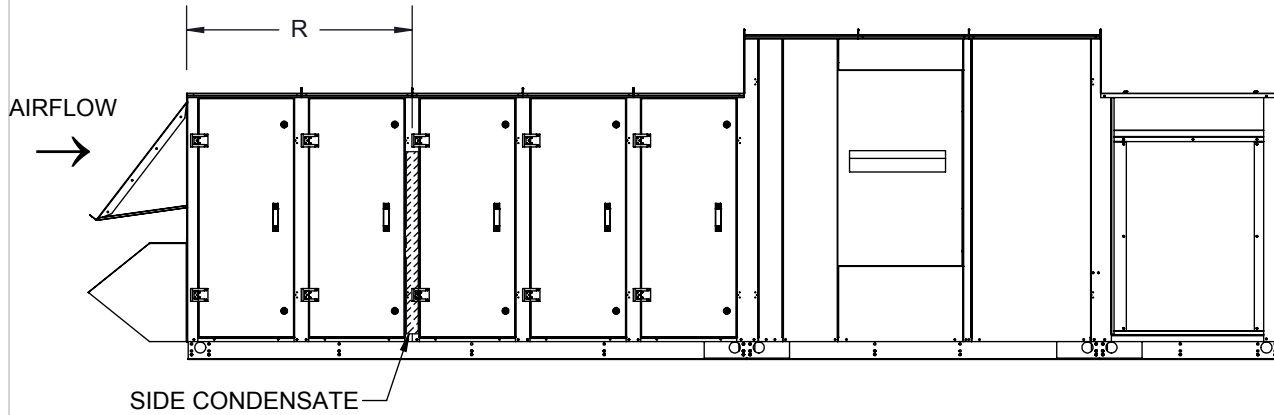

BOTTOM CUSTOMER CONNECTIONS (VIEW FROM ABOVE) ② ③ ④ ⑤ ⑥

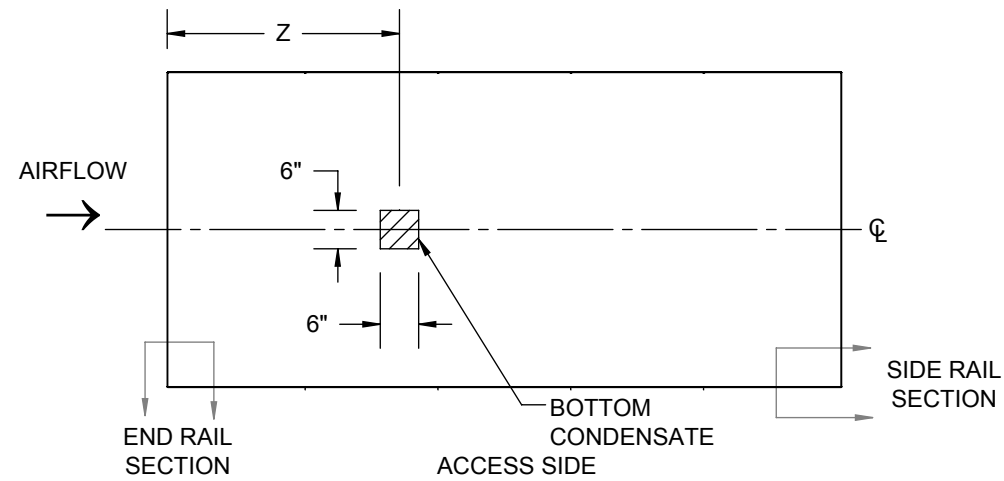

AIR FLOW	UNIT SIZE (TONS)	UNIT CABINET SIZES	GAS HEATER QTY.	R	Z
DOWN FLOW	05	44-H	1	67	54 7/8
	08	50-H	1	68 5/8	55 3/4
	10	60-H	1	70 1/2	57
			2	70 1/2	57
	15	72-H	1	75 3/8	60 1/4
			2	75 3/8	60 1/4
	20	78-H	1	81 1/4	69 7/8
			2	81 1/4	69 7/8
	25	78-H	1	81 1/4	69 7/8
			2	81 1/4	69 7/8
	30	78-H	1	81 1/4	69 7/8
			2	81 1/4	69 7/8

05 THRU 30 TON UNITS

① **END RAIL SECTION**

① **SIDE RAIL SECTION**

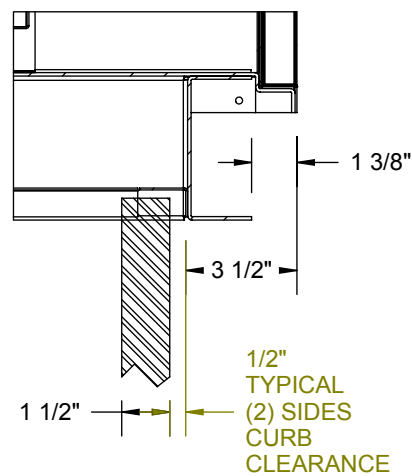
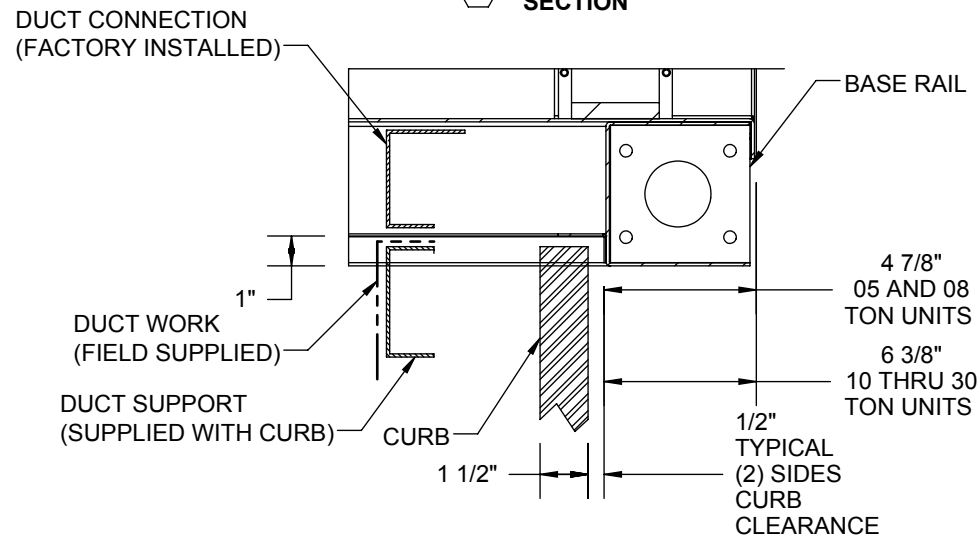

UNIT SIZE (TONS)	CAB	FILTER LOCATION	DA PART #			NOM W	NOM H	TOTAL QTY
			4" MERV	4" MERV	2" PRE			
5	44-H	S & E	870-056	870-133	870-057	18	24	6
8	50-H	S & E	870-041	870-131	870-043	20	24	6
10	60-H	S & E	870-012	870-130	870-009	24	24	6
15	72-H	SUPPLY	870-030	870-135	870-015	16	25	3
		SUPPLY	870-011	870-134	870-016	20	25	2
		EXHAUST	870-030	870-135	870-015	16	25	2
		EXHAUST	870-028	870-128	870-022	16	20	6
20-30	78-H	SUPPLY	870-010	870-129	870-005	20	20	4
		SUPPLY	870-011	870-134	870-016	20	25	4
		EXHAUST	870-030	870-135	870-015	16	25	4
		EXHAUST	870-028	870-128	870-022	16	20	4

Unit Size	5 TONS	8 TONS	10 TONS	15 TONS	20 TONS	25 TONS	30 TONS
RC DISCHARGE	3/4	7/8	7/8	1 1/8	1 1/8	1 1/8	1 3/8
RC RETURN	1/2	5/8	5/8	3/4	3/4	7/8	7/8
WATER INLET	1 1/8	1 3/8	1 3/8	1 5/8	2 5/8	2 5/8	2 5/8
WATER OUTLET	1 1/8	1 3/8	1 3/8	1 5/8	2 5/8	2 5/8	2 5/8
CONDENSATE	1	1	1	1	1	1	1

Desert Aire has a policy of continuous product and quality improvement. Specifications and dimensions are subject to change without notice. This drawing and information contained herein are the exclusive property of the Desert Aire Corporation. Any use detrimental to the interests of Desert Aire is prohibited.

All Dimensions in Inches
All Angles 90°
All outside corners 0.125" fillet
Unless Otherwise Specified

Tolerance Unless Otherwise Specified
X.X ±.125
X.XX ±.060
X.XXX ±.030
Angles ±1°



N120 W18485 FREISTADT RD
GERMANTOWN, WI 53022
Tel: (262) 946-7400
Fax: (262) 946-7401

Third Angle Projection

Part weight

Drawn	Date Released	Description
BCL	5/20/2011	PKGD w/WHEEL & GAS HEAT
Sheet	2/4	Page Title
		CUSTOMER INTERFACE GA
Scale	Rev.	Drawing Number
NTS	3	G805-017

ALL DIMENSIONS ARE IN INCHES
FRACTIONAL TOLERANCE ± 1/8"

O/A INTAKE / EXHAUST VIEW 2 3 5 6

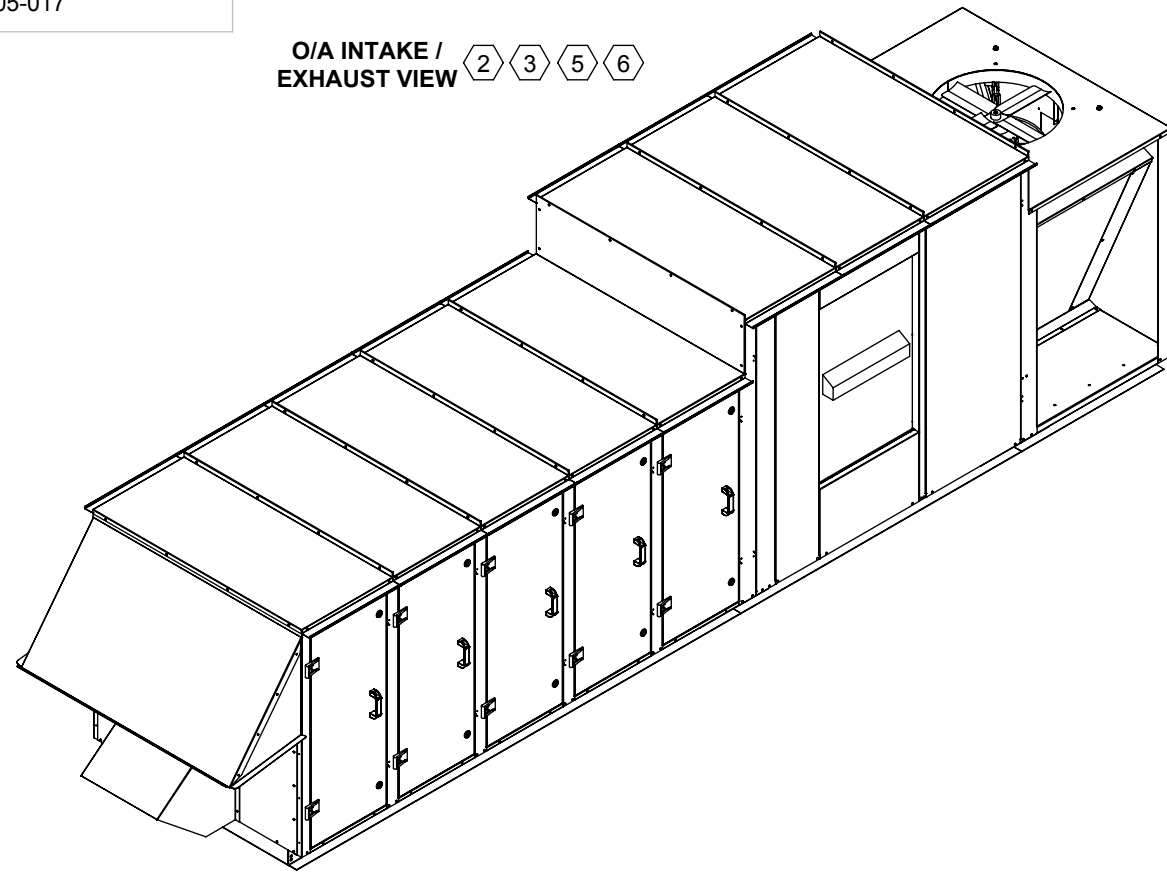

DISCHARGE / RETURN VIEW 3 5 6

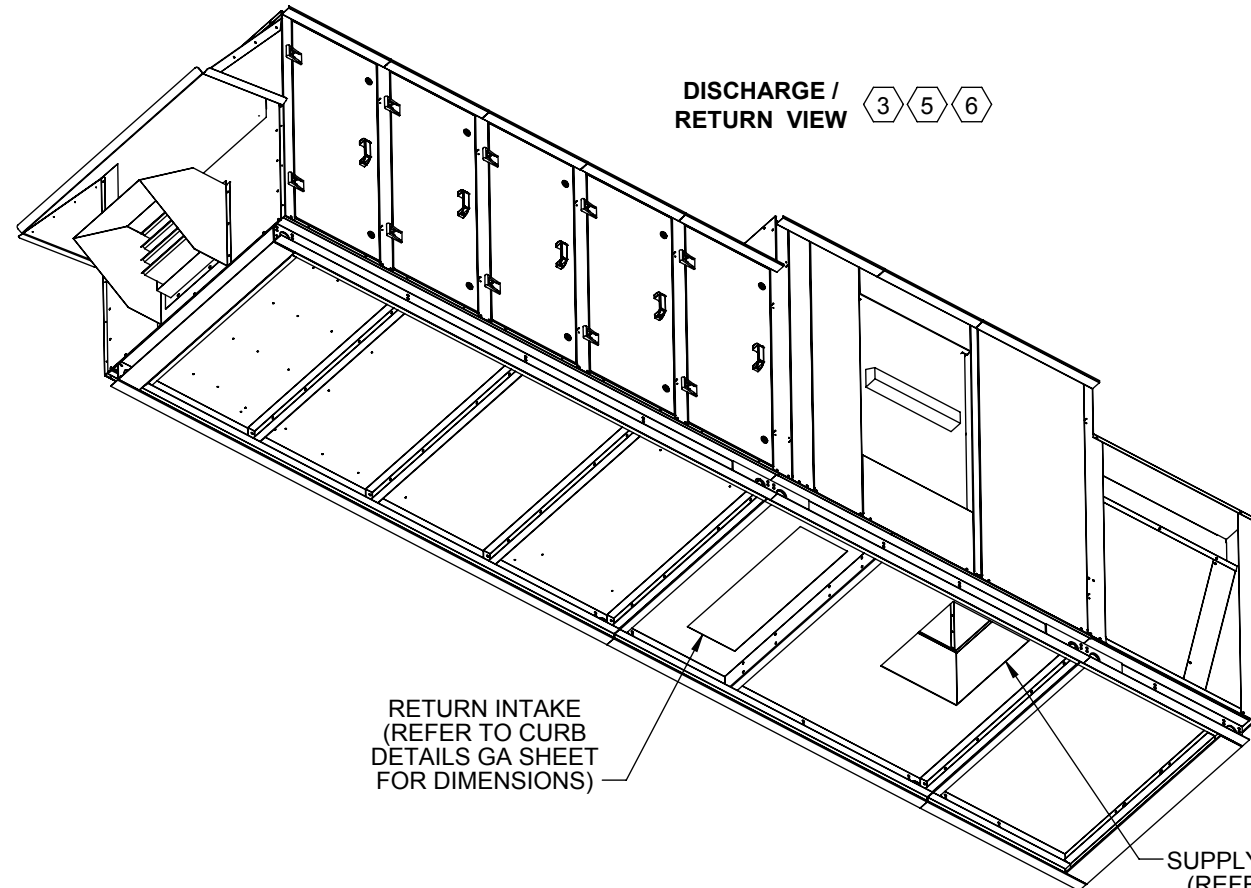

RETURN INTAKE
(REFER TO CURB
DETAILS GA SHEET
FOR DIMENSIONS)

SUPPLY DISCHARGE
(REFER TO CURB
DETAILS GA SHEET
FOR DIMENSIONS)

NOTES:

REFER TO SHEET 1 FOR GENERAL NOTES.

WEIGHTS SHOWN REFLECT FULLY OPTIONED ESTIMATED UNIT WEIGHT.

REFER TO CURB DETAILS GA SHEET FOR SUPPLY DUCT DIMENSION AND LOCATIONS.

UNIT SIZE (TONS)	UNIT CABINET SIZES	DOWN DISCHARGE, DOWN RETURN	
		GAS HEATER QTY.	TOTAL EST. WEIGHT (LBS.)
05	44-H	1	3691
08	50-H	1	4453
10	60-H	1	5630
		2	6311
15	72-H	1	7455
		2	8207
20	78-H	1	8515
		2	9680
25	78-H	1	11842
		2	13007
30	78-H	1	14009
		2	15174

Desert Aire has a policy of continuous product and quality improvement. Specifications and dimensions are subject to change without notice. This drawing and information contained herein are the exclusive property of the Desert Aire Corporation. Any use detrimental to the interests of Desert Aire is prohibited.

All Dimensions in Inches
All Angles 90°
All outside corners 0.125" fillet
Unless Otherwise Specified

Tolerance Unless Otherwise Specified
X.X ±.125
X.XX ±.060
X.XXX ±.030
Angles ±1°



N120 W18485 FREISTADT RD
GERMANTOWN, WI 53022
Tel: (262) 946-7400
Fax: (262) 946-7401



Third Angle Projection

ALL DIMENSIONS ARE IN INCHES
FRACTIONAL TOLERANCE ± 1/8"

Part weight

Drawn	Date Released	Description
BCL	5/20/2011	PKGD w/WHEEL & GAS HEAT
Sheet	3/4	Page Title
		DOWN DISCHARGE GA
Scale	Rev.	Drawing Number
NTS	3	G805-017

NOTES:
 REFER TO SHEET 1 FOR GENERAL NOTES.
 CURBS 120" AND LESS ARE SHIPPED AS COMPLETE CURBS. GREATER THAN 120" ARE SHIPPED KNOCKED DOWN.
 NUMBER AND LOCATION OF CROSS SUPPORT(S) IS DEPENDANT UPON THE GAUGE OF MATERIAL USED TO CONSTRUCT THE CURB, DUCT SUPPORT CONFIGURATION, LENGTH OF CURB, AND WIDTH OF CURB. INSTALLATION INSTRUCTIONS INCLUDED WITH CURB SHIPMENT INDICATE THE REQUIRED POSITION FOR FIELD ASSEMBLED CURBS.

DOWN/DOWN FLOW ROOFCURB DIMS												
UNIT SIZE (TONS)	UNIT CABINET SIZES	CURB P/N	WIDTH (in.)	LENGTH (in.)	SUPPLY DISCHARGE (in.)				RETURN INTAKE (in.)			
					A	B	C	D	E	F	G	H
05	44-H	CB05WPC105-XX	46 1/2	231 7/8	53 5/8	16	1 5/8	25 1/4	130 1/2	17	5 1/4	36
08	50-H	CB08WPC105-XX	53 1/8	238 1/4	57 1/2	16	1 5/8	33 1/2	141	18	5 1/8	43
10	60-H	CB10WPC105-XX	64 1/2	253 1/4	66 1/2	16	1 5/8	33 1/2	157 1/2	30	5 1/4	54
		CB10WPC205-XX	64 1/2	287 7/8	66 1/2	16	1 5/8	33 1/2	192 1/8	30	5 1/4	54
15	72-H	CB15WPC105-XX	79 1/2	265 7/8	71 1/8	16	1 5/8	44 1/2	162 1/8	31	5 1/4	69
		CB15WPC205-XX	79 1/2	300 1/2	71 1/8	16	1 5/8	44 1/2	196 3/4	31	5 1/4	69
20	78-H	CB20WPC105-XX	82 1/2	305 7/8	101 1/8	16	1 5/8	44 1/2	192 1/8	32	5 1/4	72
		CB20WPC205-XX	82 1/2	340 1/2	101 1/8	16	1 5/8	44 1/2	226 3/4	32	5 1/4	72
25	78-H	CB25WPC105-XX	82 1/2	305 7/8	101 1/8	16	1 5/8	44 1/2	192 1/8	32	5 1/4	72
		CB25WPC205-XX	82 1/2	340 1/2	101 1/8	16	1 5/8	44 1/2	226 3/4	32	5 1/4	72
30	78-H	CB30WPC105-XX	82 1/2	305 7/8	101 1/8	16	1 5/8	44 1/2	192 1/8	32	5 1/4	72
		CB30WPC205-XX	82 1/2	340 1/2	101 1/8	16	1 5/8	44 1/2	226 3/4	32	5 1/4	72

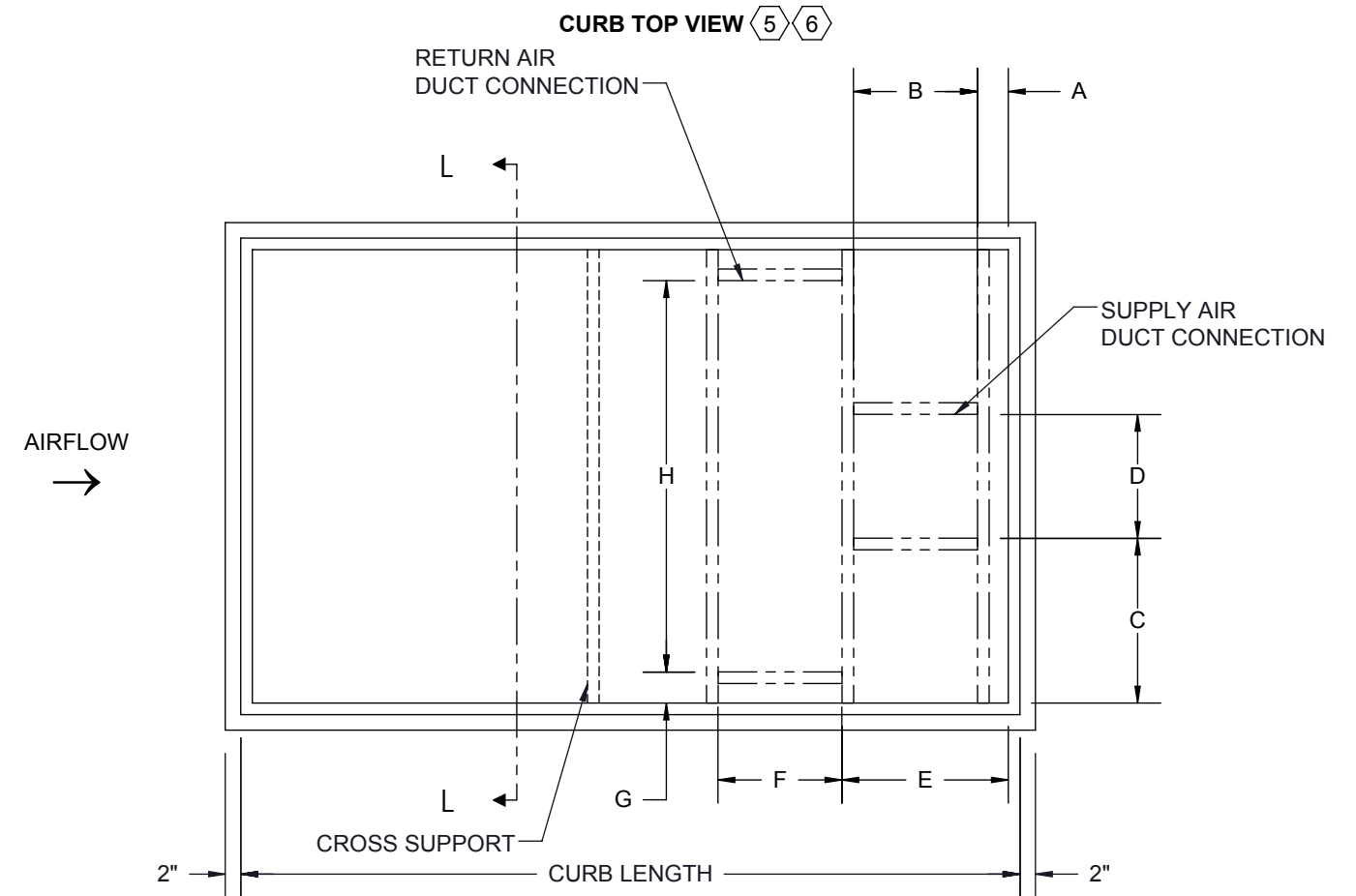
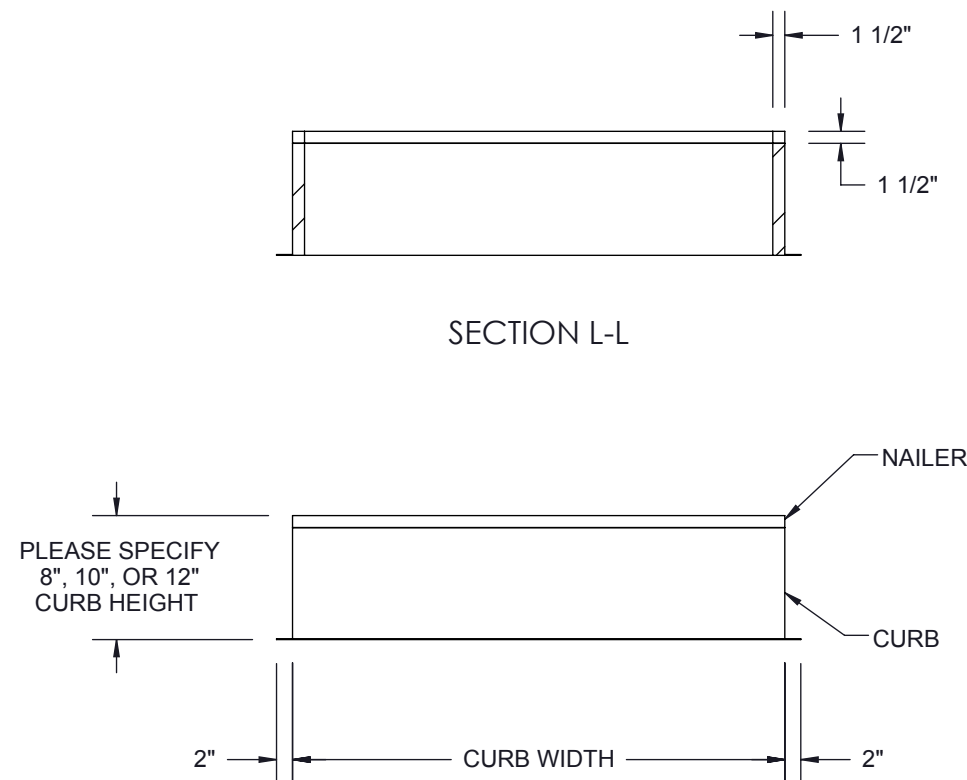

DUCT CONNECTIONS FOR DOWN DISCHARGE / DOWN RETURN

Desert Aire has a policy of continuous product and quality improvement. Specifications and dimensions are subject to change without notice. This drawing and information contained herein are the exclusive property of the Desert Aire Corporation. Any use detrimental to the interests of Desert Aire is prohibited.	All Dimensions in Inches All Angles 90° All outside corners 0.125" fillet Unless Otherwise Specified	Tolerance Unless Otherwise Specified X.X ±.125 X.XX ±.060 X.XXX ±.030 Angles ±1°	N120 W18485 FREISTADT RD GERMANTOWN, WI 53022 Tel: (262) 946-7400 Fax: (262) 946-7401
ALL DIMENSIONS ARE IN INCHES FRACTIONAL TOLERANCE ± 1/8"	Third Angle Projection	Sheet: 4/4	Page Title: CURB DETAILS
Part weight	Scale: NTS	Rev: 3	Drawing Number: G805-017