

AIR FLOW	UNIT SIZE (TONS)	UNIT CABINET SIZES	L1	W1	H1	L2	W2
DOWN FLOW	02	24	146 1/8	37 1/8	46 3/8	168 1/8	43 1/8
	03		146 1/8	37 1/8	46 3/8	168 1/8	43 1/8
	05		160 1/2	37 1/8	46 3/8	182 5/8	43 1/8
	08	36	195 5/8	49 1/8	51 1/8	220 1/8	55 1/8
	10		195 5/8	49 1/8	51 1/8	220 1/8	55 1/8
	15		195 5/8	49 1/8	51 1/8	220 1/8	55 1/8
	20	44	221 1/4	54 1/2	55 1/8	247 3/4	60 1/2
	25	50	238 1/8	61 1/8	63 1/8	268 3/4	67 1/8
30	271 7/8		61 1/8	63 1/8	302 3/8	67 1/8	
TOP FLOW	02	24	146 1/8	37 1/8	46 3/8	168 1/8	43 1/8
	03		146 1/8	37 1/8	46 3/8	168 1/8	43 1/8
	05		160 1/2	37 1/8	46 3/8	182 5/8	43 1/8
	08	36	195 5/8	49 1/8	51 1/8	220 1/8	55 1/8
	10		195 5/8	49 1/8	51 1/8	220 1/8	55 1/8
	15		195 5/8	49 1/8	51 1/8	220 1/8	55 1/8
	20	44	221 1/4	54 1/2	55 1/8	247 3/4	60 1/2
	25	50	238 1/8	61 1/8	63 1/8	268 3/4	67 1/8
30	271 7/8		61 1/8	63 1/8	302 3/8	67 1/8	

ACCESS SIDE VIEW (2, 6, 7)

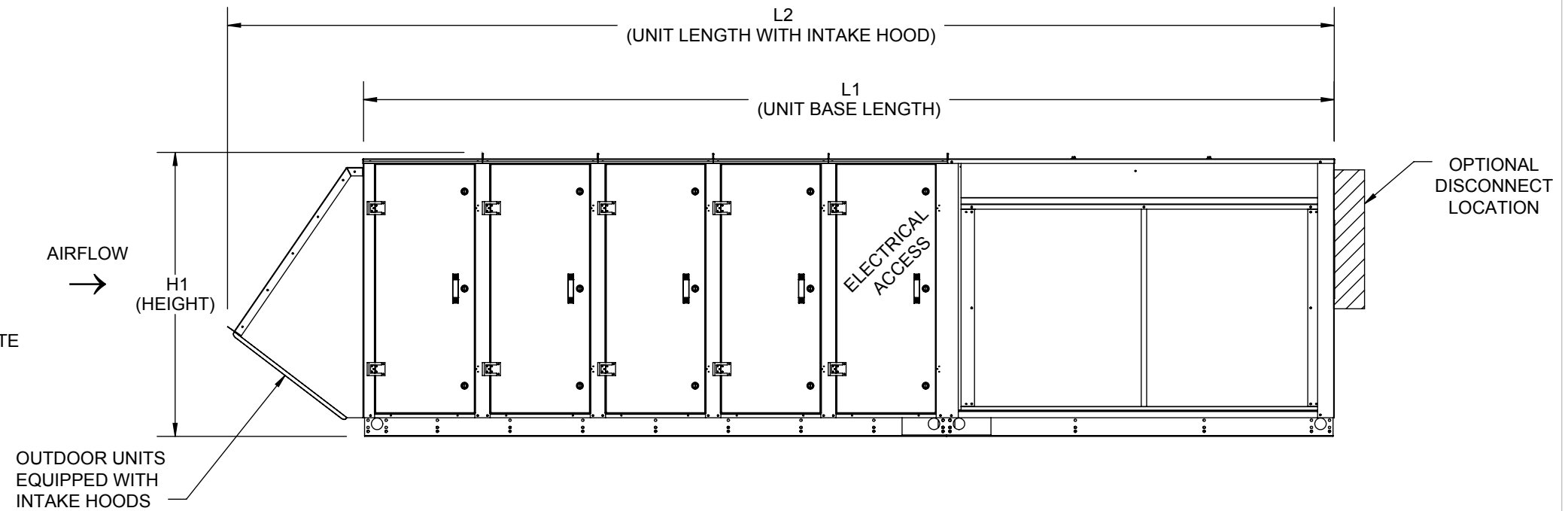
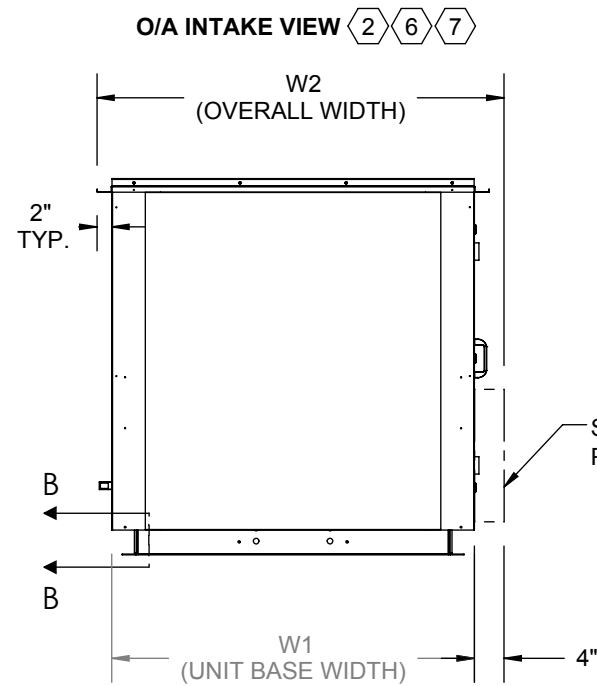

GENERAL NOTES AS REFERENCED BY INDIVIDUAL SHEETS:

- ① PORTION OF SECTIONED OR DETAILED DRAWING HAS BEEN OMITTED FOR CLARITY.
- ② HOODS OMITTED FOR CLARITY.
- ③ VIEW IS FOR PICTORAL PURPOSES. REFER TO PAGE 1 FOR UNIT TYPE SPECIFIC VIEW.
- ④ REFER TO SUBMITTAL FOR CUSTOMER CONNECTION LOCATIONS.
- ⑤ DIMENSIONS ARE TO ACCESS SIDE OF UNIT.
- ⑥ RH ACCESS SHOWN FOR DISPLAY PURPOSES. ACCESS DOOR CONFIGURATION MAY CHANGE DEPENDING ON UNIT SIZE.
- ⑦ REFER TO SHEET 3,4,5 FOR INTAKE AND DISCHARGE CONNECTION DIMENSIONS.

Desert Aire has a policy of continuous product and quality improvement. Specifications and dimensions are subject to change without notice. This drawing and information contained herein are the exclusive property of the Desert Aire Corporation. Any use detrimental to the interests of Desert Aire is prohibited.

All Dimensions in Inches
All Angles 90°
All outside corners 0.125" fillet
Unless Otherwise Specified

Tolerance Unless Otherwise Specified
X.X ±.125
X.XX ±.060
X.XXX ±.030
Angles ±1°

DESERT AIRE
N120 W18485 FREISTADT RD
GERMANTOWN, WI 53022
Tel: (262) 946-7400
Fax: (262) 946-7401



Third Angle Projection

Part weight

Drawn	Date Released	Description
BCL	5/11/2011	EXTENDED PACKAGED
Sheet	1/5	Page Title
		GENERAL ARRANGEMENT
Scale	Rev.	Drawing Number
NTS	4	G805-010

ALL DIMENSIONS ARE IN INCHES
FRACTIONAL TOLERANCE ± 1/8"

NOTES:
REFER TO SHEET 1 FOR GENERAL NOTES.

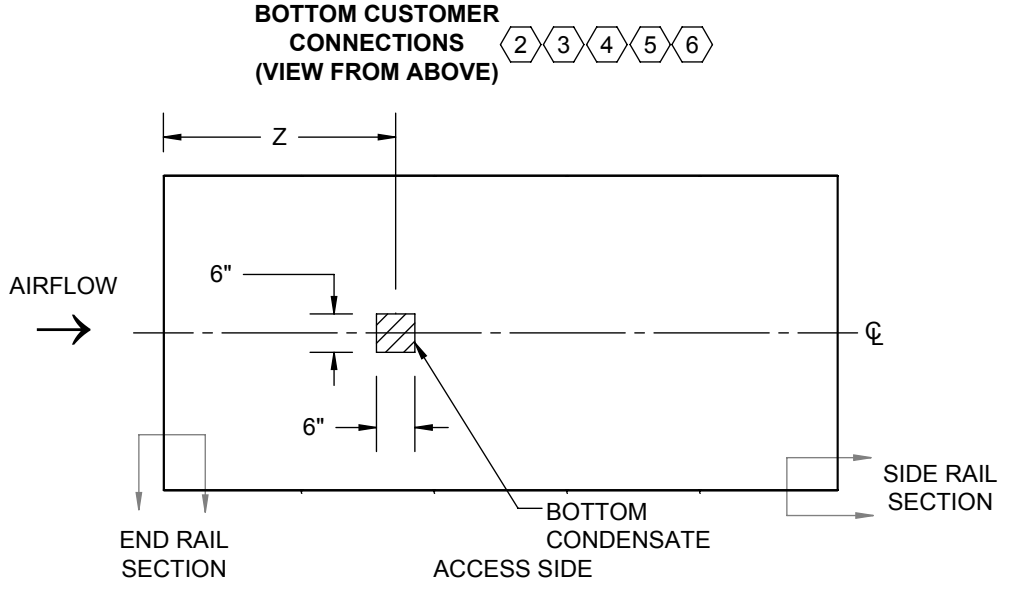
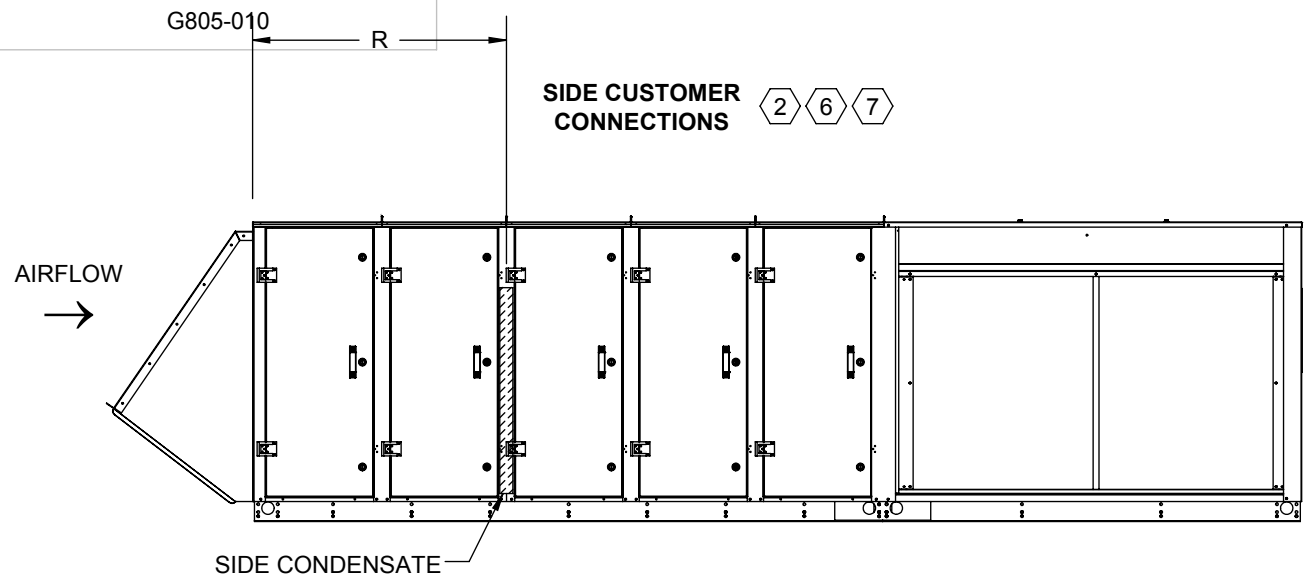

AIR FLOW	UNIT SIZE (TONS)	UNIT CABINET SIZES	R	Z
DOWN FLOW	02	24	53 1/4	30 1/4
	03		53 1/4	30 1/4
	05		53 1/4	30 1/4
	08	36	42 3/8	42 3/8
	10		42 3/8	42 3/8
	15		42 3/8	42 3/8
	20	44	45	44 7/8
25	50	45 3/4	45 3/4	
30		45 3/4	45 3/4	
TOP FLOW	02	24	53 1/4	30 1/4
	03		53 1/4	30 1/4
	05		53 1/4	30 1/4
	08	36	42 3/8	42 3/8
	10		42 3/8	42 3/8
	15		42 3/8	42 3/8
	20	44	45	44 7/8
	25	50	45 3/4	45 3/4
	30		45 3/4	45 3/4

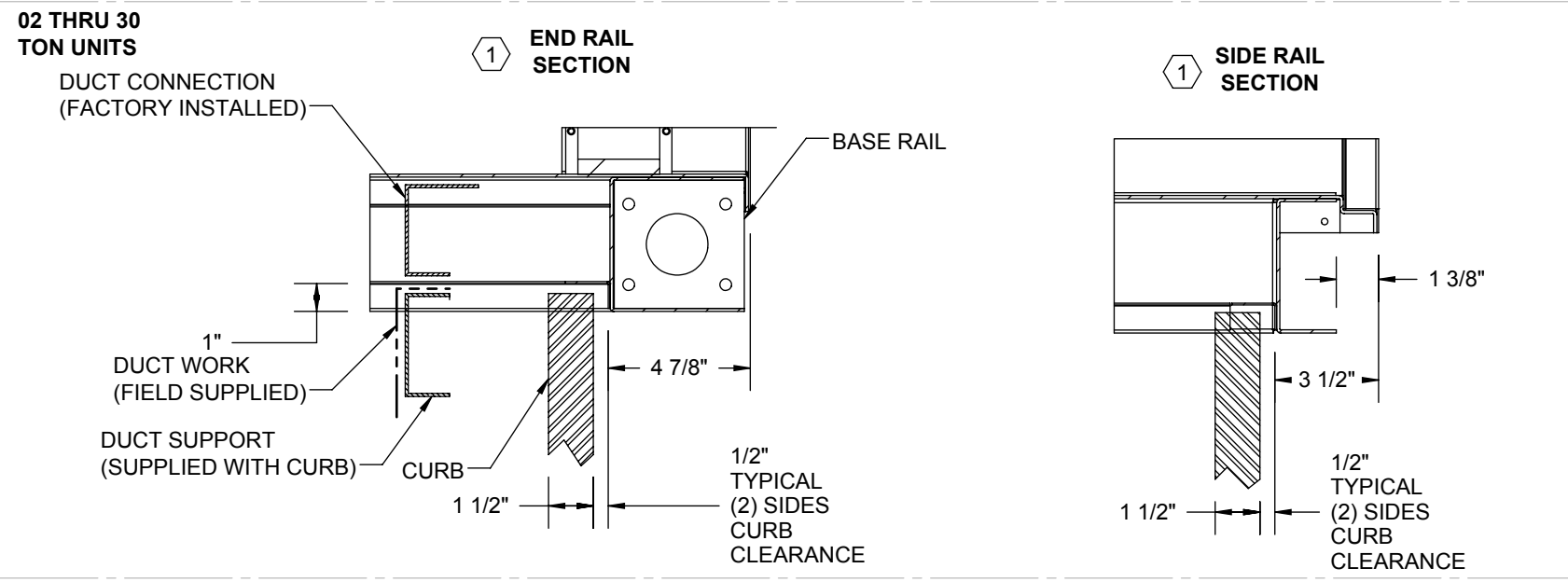

UNIT SIZE (TONS)	CAB	DA PART #			NOM W	NOM H	QTY
		4" MERV 7/8	4" MERV	2" PRE			
2-5	24	870-056	870-133	870-057	18	24	2
8-15	36	870-028	870-128	870-022	16	20	6
20	44	870-028	870-128	870-022	16	20	4
		870-010	870-129	870-005	20	20	2
25-30	50	870-041	870-131	870-043	20	24	6
36-46	60	870-010	870-129	870-005	20	20	6
		870-028	870-128	870-022	16	20	6
50-60	72	870-028	870-128	870-022	16	20	12
		870-041	870-131	870-043	20	24	3

CUSTOMER CONNECTION LINE SIZE SUMMARY (in.)									
Unit Size	2 TONS	3 TONS	5 TONS	8 TONS	10 TONS	15 TONS	20 TONS	25 TONS	30 TONS
CONDENSATE	1	1	1	1	1	1	1	1	1

Desert Aire has a policy of continuous product and quality improvement. Specifications and dimensions are subject to change without notice. This drawing and information contained herein are the exclusive property of the Desert Aire Corporation. Any use detrimental to the interests of Desert Aire is prohibited.

All Dimensions in Inches
All Angles 90°
All outside corners 0.125" fillet
Unless Otherwise Specified

Tolerance Unless Otherwise Specified
X.X ±.125
X.XX ±.060
X.XXX ±.030
Angles ±1°

DESERT AIRE
N120 W18485 FREISTADT RD
GERMANTOWN, WI 53022
Tel: (262) 946-7400
Fax: (262) 946-7401

Drawn: BCL, Date Released: 5/11/2011, Description: EXTENDED PACKAGED

Sheet: 2/5, Page Title: CUSTOMER INTERFACE GA

Scale: NTS, Rev: 4, Drawing Number: G805-010

Third Angle Projection

ALL DIMENSIONS ARE IN INCHES
FRACTIONAL TOLERANCE ± 1/8"

O/A INTAKE VIEW 3 5 6

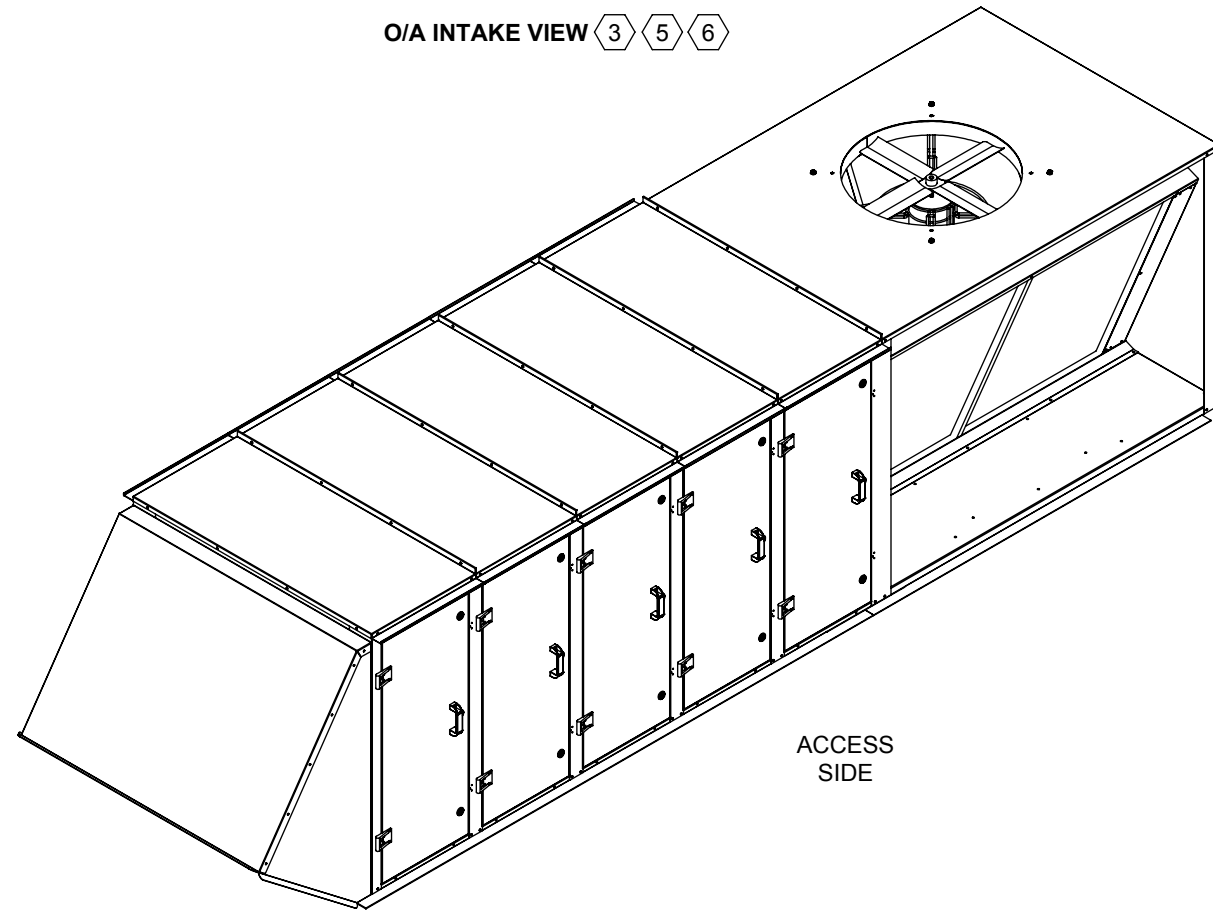

ACCESS SIDE

DISCHARGE VIEW 3 5 6

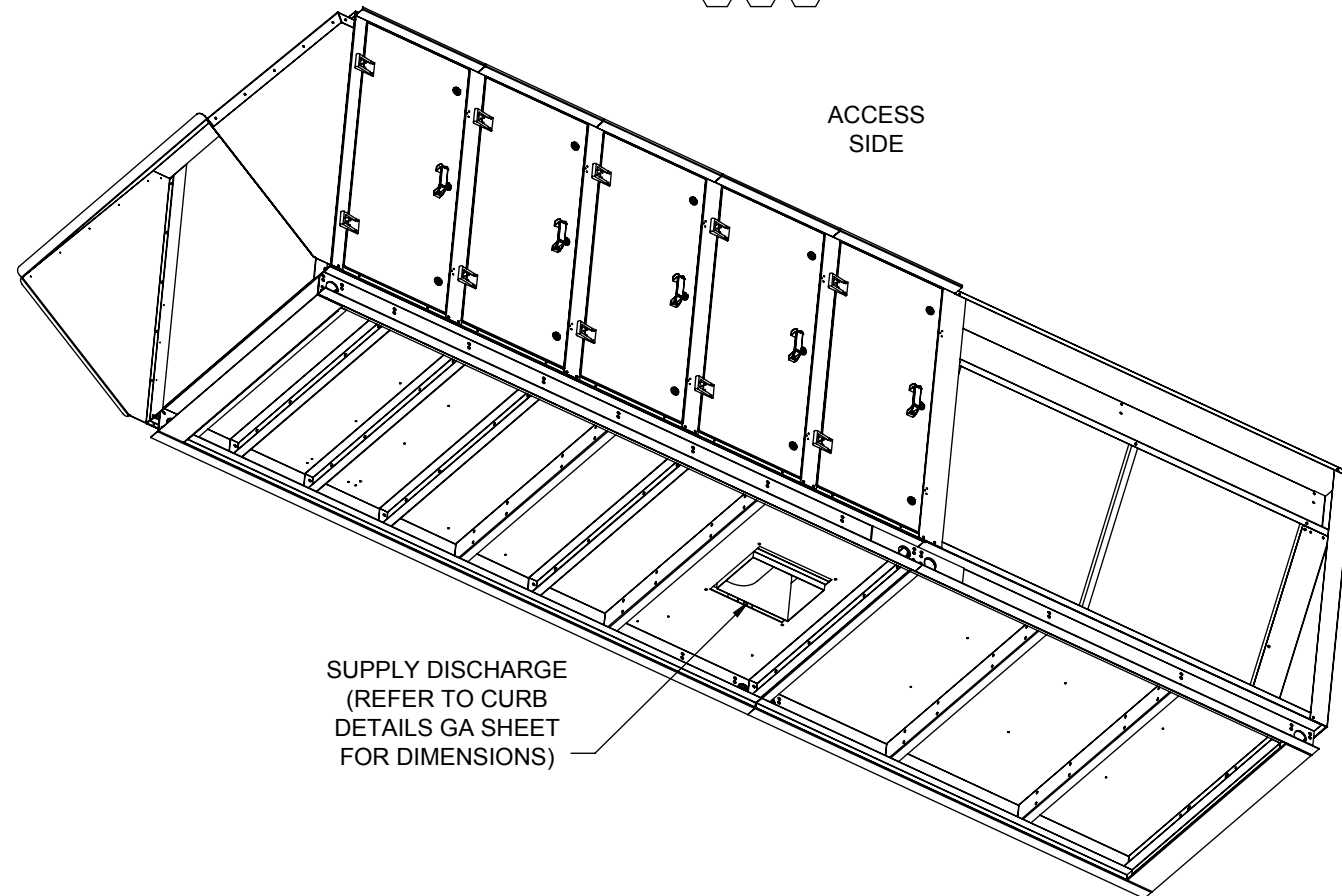

ACCESS SIDE

SUPPLY DISCHARGE
(REFER TO CURB
DETAILS GA SHEET
FOR DIMENSIONS)

NOTES:

REFER TO SHEET 1 FOR GENERAL NOTES.

WEIGHTS SHOWN REFLECT FULLY OPTIONED ESTIMATED UNIT WEIGHT.

REFER TO CURB DETAILS GA SHEET FOR SUPPLY DUCT DIMENSION AND LOCATIONS.

UNIT SIZE (TONS)	UNIT CABINET SIZES	DOWN DISCHARGE
		TOTAL EST. WEIGHT (LBS.)
02	24	1445
03		1494
05		1736
08	36	2450
10		2651
15		3077
20	44	3600
25	50	4291
30		4835

Desert Aire has a policy of continuous product and quality improvement. Specifications and dimensions are subject to change without notice. This drawing and information contained herein are the exclusive property of the Desert Aire Corporation. Any use detrimental to the interests of Desert Aire is prohibited.

All Dimensions in Inches
All Angles 90°
All outside corners 0.125" fillet
Unless Otherwise Specified

Tolerance Unless Otherwise Specified
X.X ±.125
X.XX ±.060
X.XXX ±.030
Angles ±1°



N120 W18485 FREISTADT RD
GERMANTOWN, WI 53022
Tel: (262) 946-7400
Fax: (262) 946-7401



Third Angle Projection

ALL DIMENSIONS ARE IN INCHES
FRACTIONAL TOLERANCE ± 1/8"

Part weight

Drawn	Date Released	Description
BCL	5/11/2011	EXTENDED PACKAGED
Sheet		Page Title
3/5		DOWN DISCHARGE GA
Scale	Rev.	Drawing Number
NTS	4	G805-010

NOTES:
 REFER TO SHEET 1 FOR GENERAL NOTES.
 WEIGHTS SHOWN REFLECT FULLY OPTIONED
 ESTIMATED UNIT WEIGHT.

UNIT SIZE (TONS)	UNIT CABINET SIZES	TOP DISCHARGE				TOTAL EST. WEIGHT (LBS.)
		SUPPLY DISCHARGE (in.)				
		A1	B1	C1 5	D1	
02	24	40 3/4	13 3/4	13 5/8	9 7/8	1445
03		40 3/4	13 3/4	13 5/8	9 7/8	1494
05		55 1/8	12 1/2	13 5/8	9 7/8	1736
08	36	70 3/4	17	16 5/8	15 3/4	2450
10		70 3/4	17	16 5/8	15 3/4	2651
15		70 3/4	17	16 5/8	15 3/4	3077
20	44	88 5/8	29 3/8	17 7/8	18 3/4	3600
25	50	102 1/8	29 3/8	19 1/2	22 1/8	4291
30		135 7/8	29 3/8	19 1/2	22 1/8	4835

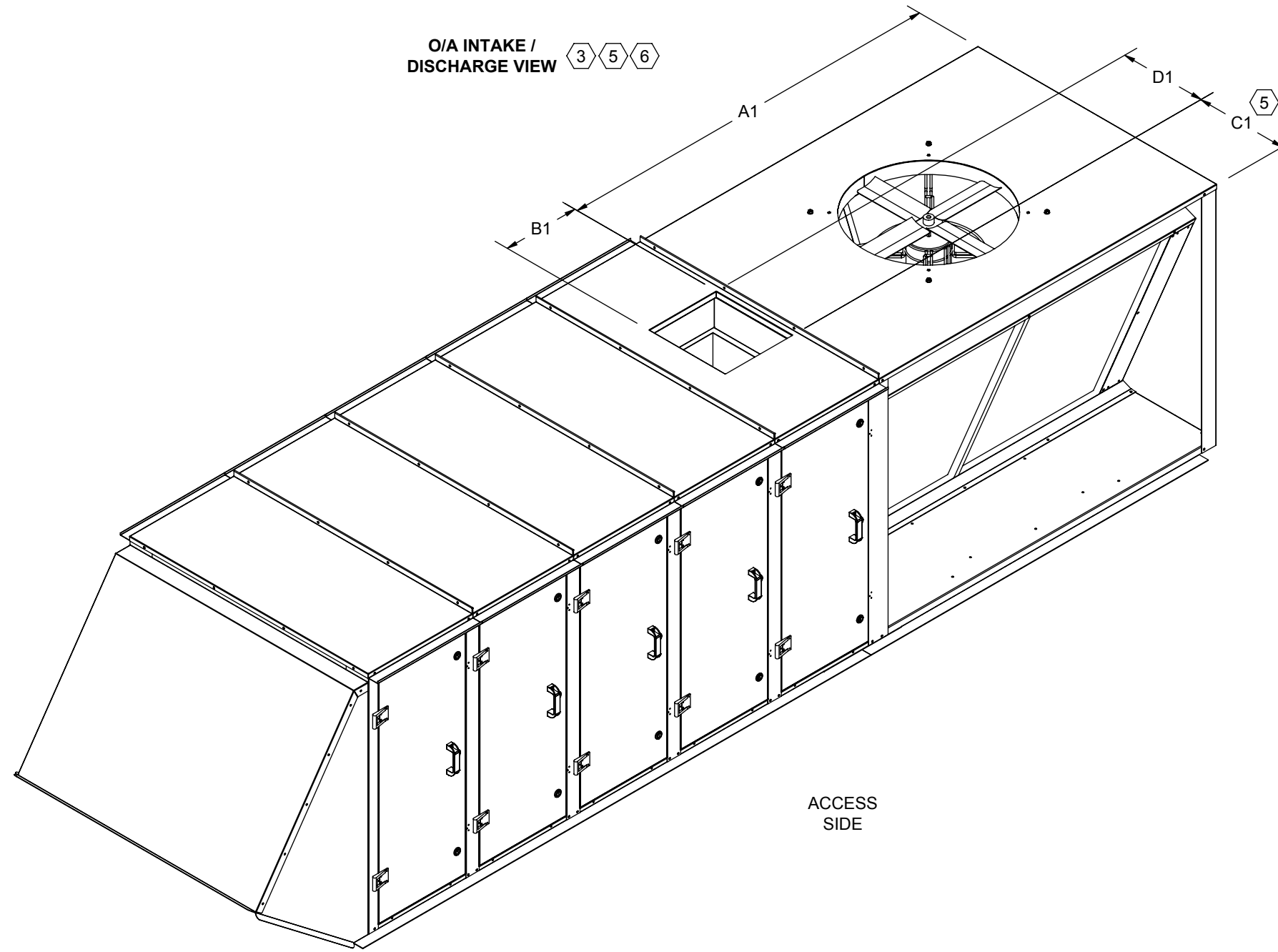

Desert Aire has a policy of continuous product and quality improvement. Specifications and dimensions are subject to change without notice. This drawing and information contained herein are the exclusive property of the Desert Aire Corporation. Any use detrimental to the interests of Desert Aire is prohibited.	All Dimensions in Inches All Angles 90° All outside corners 0.125" fillet Unless Otherwise Specified	Tolerance Unless Otherwise Specified X.X ±.125 X.XX ±.060 X.XXX ±.030 Angles ±1°	 N120 W18485 FREISTADT RD GERMANTOWN, WI 53022 Tel: (262) 946-7400 Fax: (262) 946-7401	
				Drawn: BCL Date Released: 5/11/2011 Description: EXTENDED PACKAGED
				Sheet: 4/5 Page Title: TOP DISCHARGE GA
ALL DIMENSIONS ARE IN INCHES FRACTIONAL TOLERANCE ± 1/8"	Third Angle Projection	Scale: NTS Rev: 4	Drawing Number: G805-010	

NOTES:
 REFER TO SHEET 1 FOR GENERAL NOTES.
 CURBS 120" AND LESS ARE SHIPPED AS COMPLETE CURBS. GREATER THAN 120" ARE SHIPPED KNOCKED DOWN.
 NUMBER AND LOCATION OF CROSS SUPPORT(S) IS DEPENDANT UPON THE GAUGE OF MATERIAL USED TO CONSTRUCT THE CURB, DUCT SUPPORT CONFIGURATION, LENGTH OF CURB AND WIDTH OF CURB. INSTALLATION INSTRUCTIONS INCLUDED WITH CURB SHIPMENT INDICATE THE REQUIRED POSITION FOR FIELD ASSEMBLED CURBS.

UNIT SIZE (TONS)	UNIT CABINET SIZES	TOP FLOW ROOFCURB DIMS			DOWN FLOW ROOFCURB DIMS						
		CURB P/N	WIDTH (in.)	LENGTH (in.)	CURB P/N	WIDTH (in.)	LENGTH (in.)	SUPPLY DISCHARGE (in.)			
								A	B	C ⁵	D
02	24	CB02NPBN04-XX	29 1/8	135 1/4	CB02NPCN04-XX	29 1/8	135 1/4	35 1/2	11 1/2	8 1/8	9 7/8
03		CB03NPBN04-XX	29 1/8	135 1/4	CB03NPCN04-XX	29 1/8	135 1/4	35 1/2	11 1/2	8 1/8	9 7/8
05		CB05NPBN04-XX	29 1/8	149 5/8	CB05NPCN04-XX	29 1/8	149 5/8	49 7/8	11 1/2	8 1/8	9 7/8
08	36	CB08NPBN06-XX	41 1/8	184 7/8	CB08NPCN06-XX	41 1/8	184 7/8	69 1/2	13 3/4	11 1/8	15 3/4
10		CB10NPBN06-XX	41 1/8	184 7/8	CB10NPCN06-XX	41 1/8	184 7/8	69 1/2	13 3/4	11 1/8	15 3/4
15		CB15NPBN06-XX	41 1/8	184 7/8	CB15NPCN06-XX	41 1/8	184 7/8	69 1/2	13 3/4	11 1/8	15 3/4
20	44	CB20NPBN06-XX	46 1/2	210 1/2	CB20NPCN06-XX	46 1/2	210 1/2	87 3/8	16	12 3/8	18 3/4
25	50	CB25NPBN06-XX	53 1/8	227 3/8	CB25NPCN06-XX	53 1/8	227 3/8	101	19	14	22 1/8
30		CB30NPBN06-XX	53 1/8	261 1/8	CB30NPCN06-XX	53 1/8	261 1/8	134 5/8	19	14	22 1/8



SECTION L-L

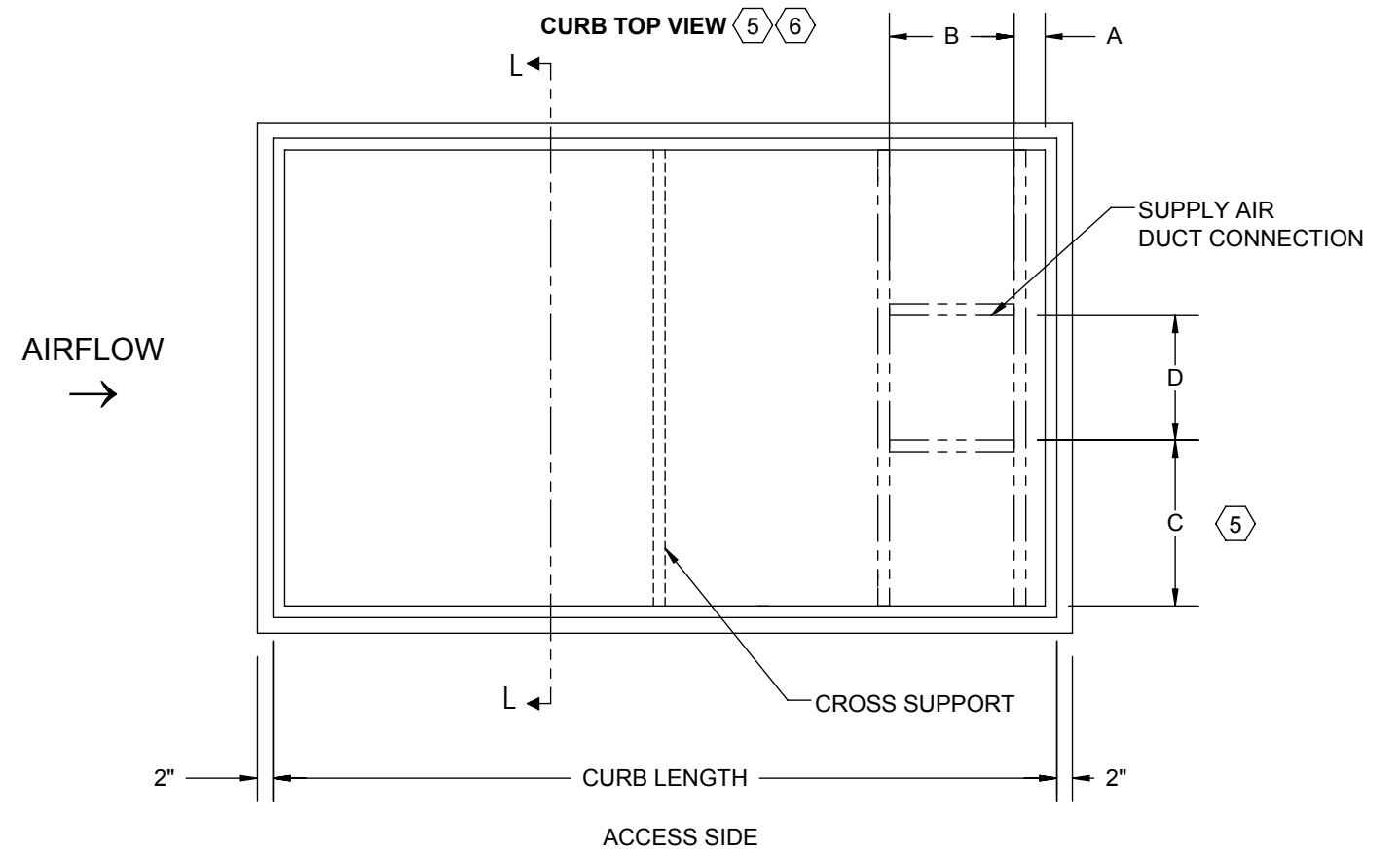
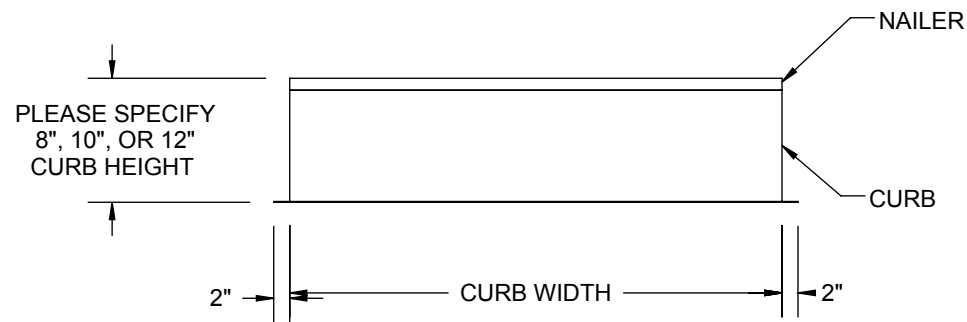

----- DUCT CONNECTIONS FOR DOWN DISCHARGE

Desert Aire has a policy of continuous product and quality improvement. Specifications and dimensions are subject to change without notice. This drawing and information contained herein are the exclusive property of the Desert Aire Corporation. Any use detrimental to the interests of Desert Aire is prohibited.	All Dimensions in Inches All Angles 90° All outside corners 0.125" fillet Unless Otherwise Specified	Tolerance Unless Otherwise Specified X.X ±.125 X.XX ±.060 X.XXX ±.030 Angles ±1°	N120 W18485 FREISTADT RD GERMANTOWN, WI 53022 Tel: (262) 946-7400 Fax: (262) 946-7401	
			Drawn: BCL Date Released: 5/11/2011 Description: EXTENDED PACKAGED	
ALL DIMENSIONS ARE IN INCHES FRACTIONAL TOLERANCE ± 1/8"	Third Angle Projection 	Sheet: 5/5 Page Title: CURB DETAILS GA	Scale: NTS Rev: 4 Drawing Number: G805-010	