

G900-003-G

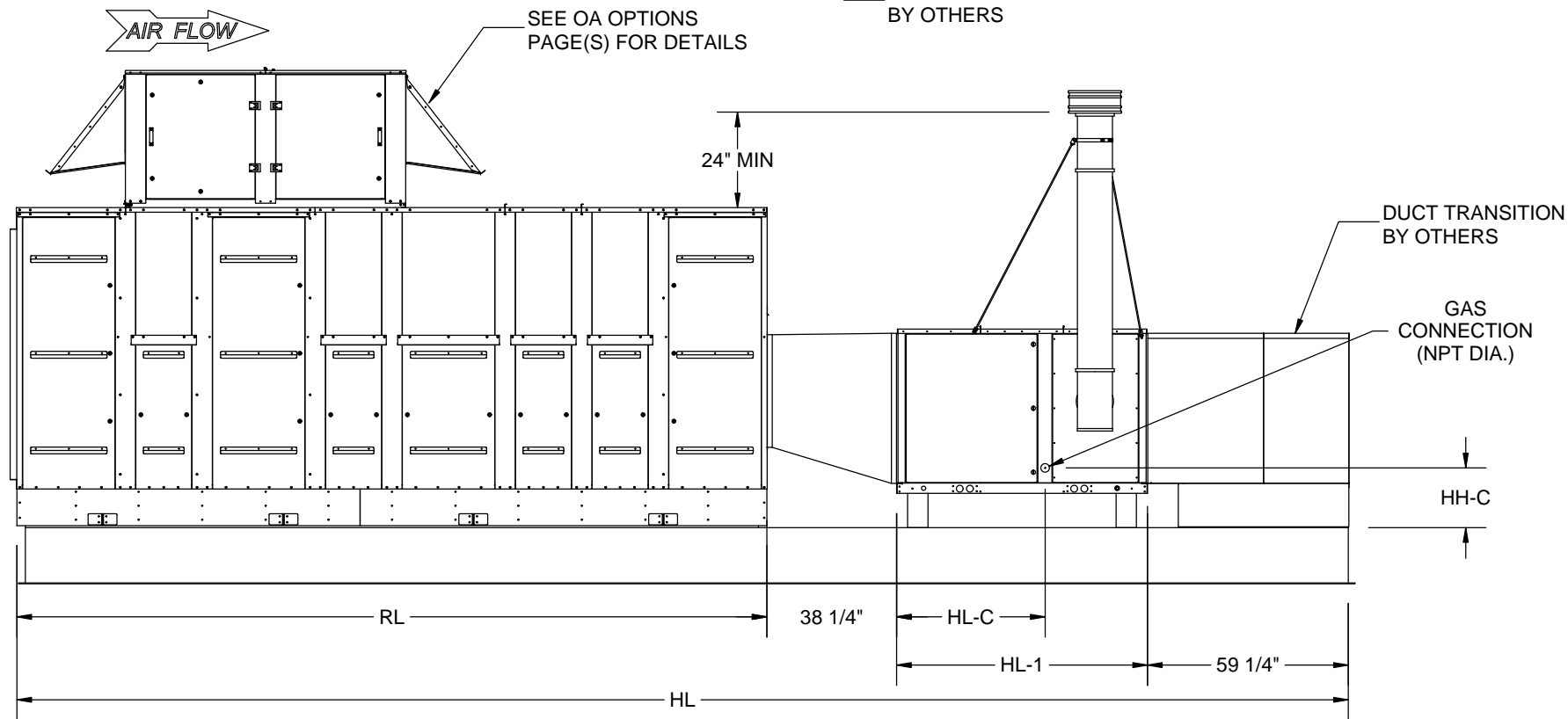

HEATER SIZE	RL	HL	HL-C	HL-1	HH-C	HW	NPT DIA.
HF550	221 1/4	378 3/4	38 1/4	60	17	99 1/4	1 1/4
HF750	221 1/4	392 3/4	43 3/8	74	17 1/8	103 1/4	1 1/4
HF1000	221 1/4	398 3/4	45	80	17 3/8	106 1/4	1 1/2
HF1250	221 1/4	404 3/4	45	86	17 3/8	106 1/4	1 1/2
HF1500	221 1/4	404 3/4	50 1/2	86	18 1/4	133 1/4	2
HF1750	221 1/4	404 3/4	44 1/2	86	18 1/4	133 1/4	2
HF2000	221 1/4	414 3/4	67 3/4	96	18 1/2	138 1/4	2

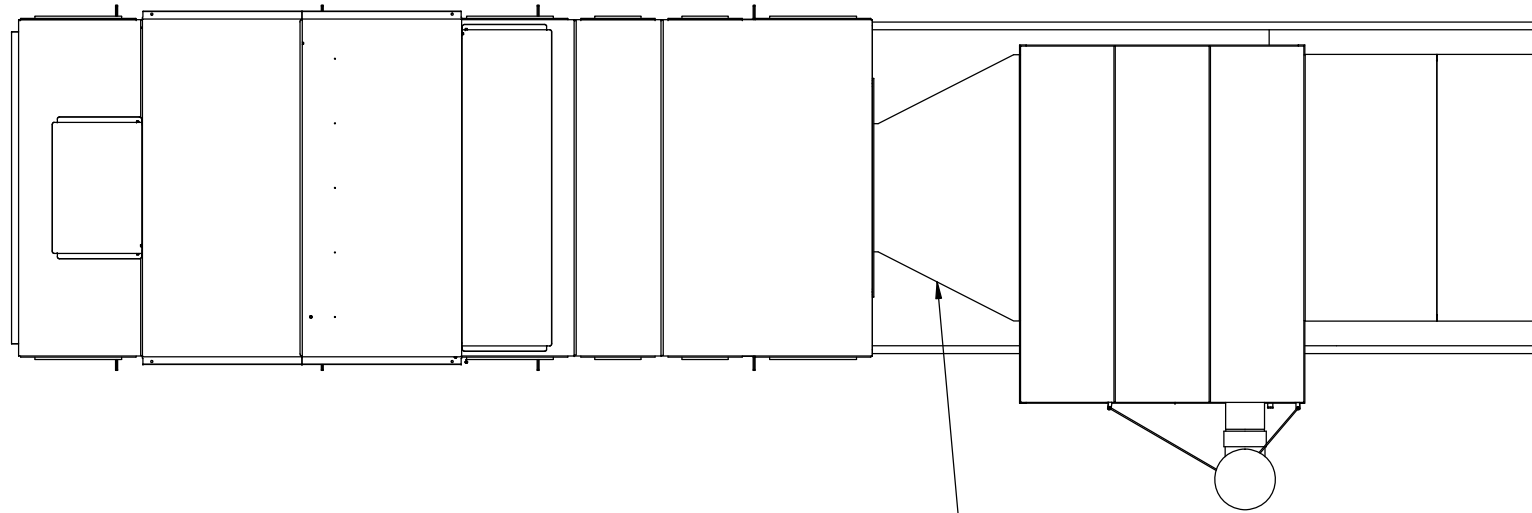
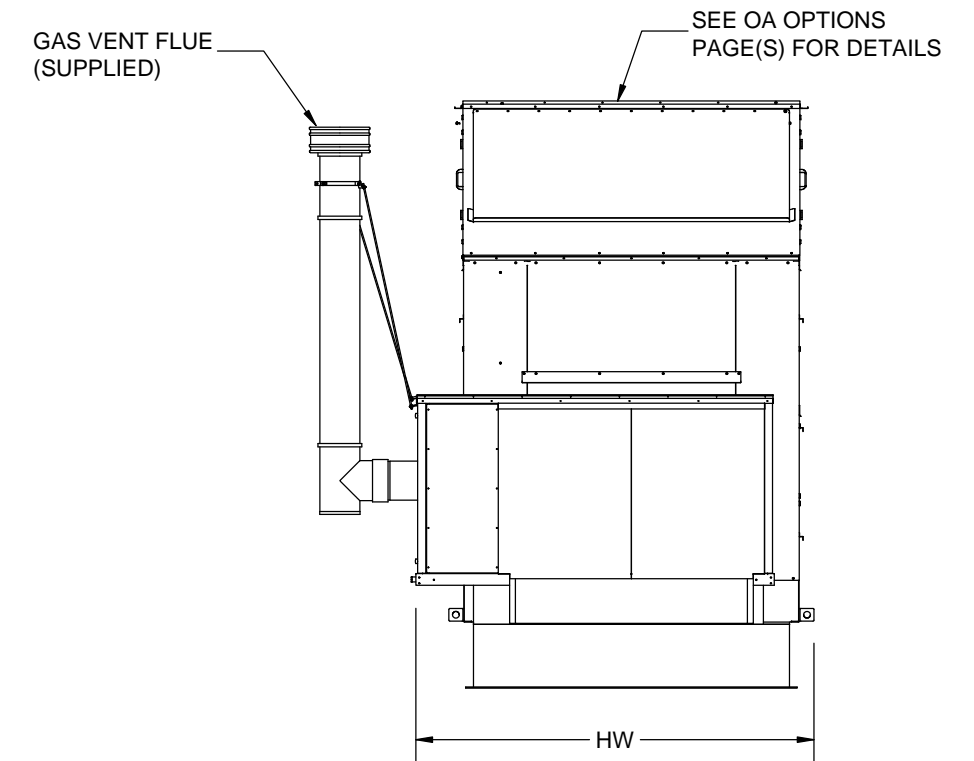

NOTE:  
CONSULT MAIN GENERAL ARRANGEMENT DRAWING FOR UNIT SPECIFIC DIMENSIONS.

Desert Aire has a policy of continuous product and quality improvement. Specifications and dimensions are subject to change without notice. This drawing and information contained herein are the exclusive property of the Desert Aire Corporation. Any use detrimental to the interests of Desert Aire is prohibited.	All Dimensions in Inches All Angles 90° All outside corners 0.125" fillet Unless Otherwise Specified	Tolerance Unless Otherwise Specified X.X ±.125 X.XX ±.060 X.XXX ±.030 Angles ±1°	N120 W18485 FREISTADT RD GERMANTOWN, WI 53022 Tel: (262) 946-7400 Fax: (262) 946-7401
	Third Angle Projection	Drawn: MHB Date Released: 4/8/2015	
ALL DIMENSIONS ARE IN INCHES TOLERANCE ± 1/8"	Part weight	Sheet: 1/6 Scale: NTS Rev.: 0	Drawing Number: G900-003-G

BLOWER NUMBER		
60 TON		
BLOWER	BW	BH
ATLI 25-25	33 1/8	33 1/8
ATZAF 25-25	33 1/8	33 1/8
ATZAF 28-28	37	37
ATZAF 32-32	41 1/4	41 1/4

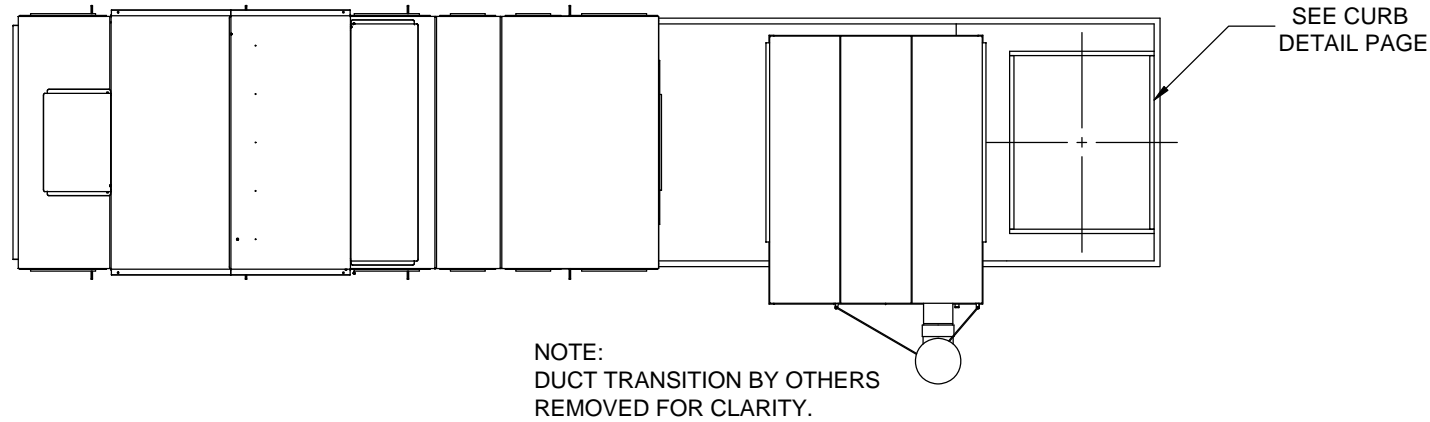

NOTE:  
HEATER INLET AND OUTLET ARE THE SAME DIMENSIONS

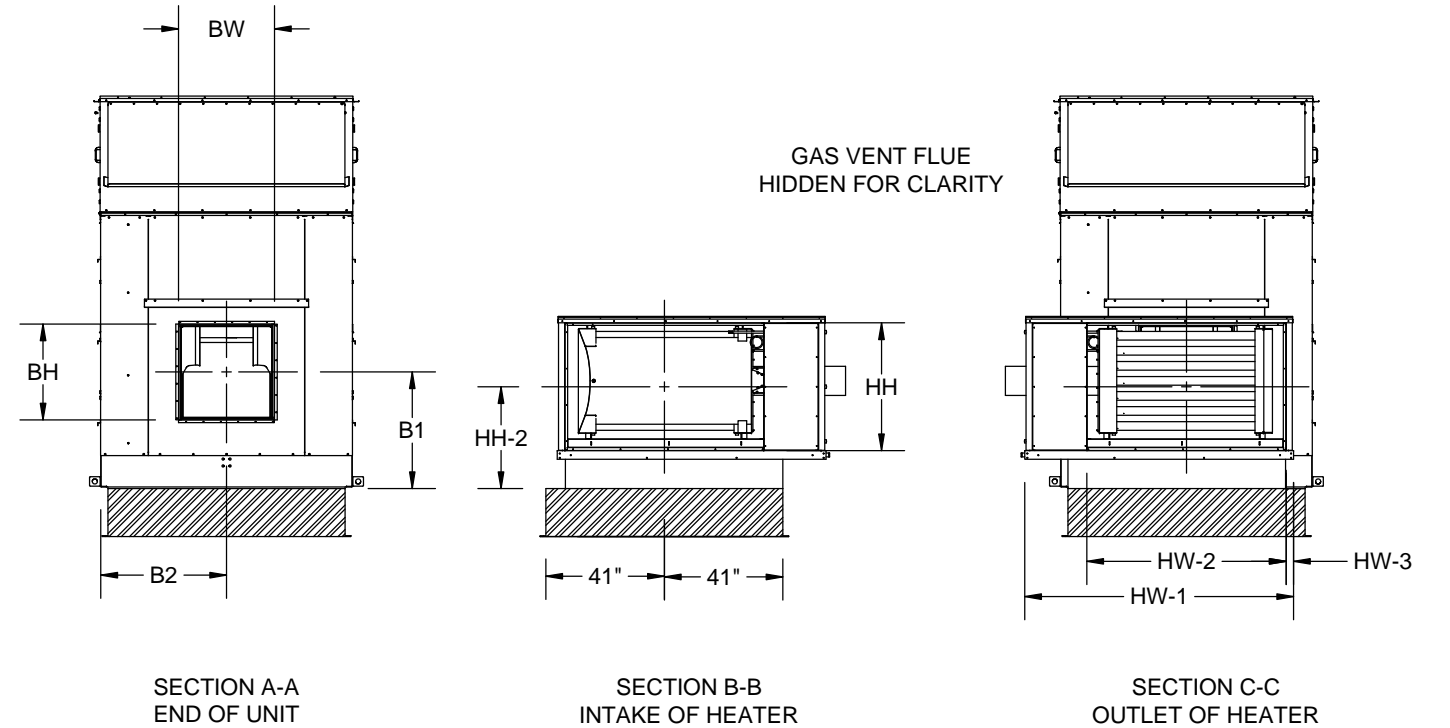
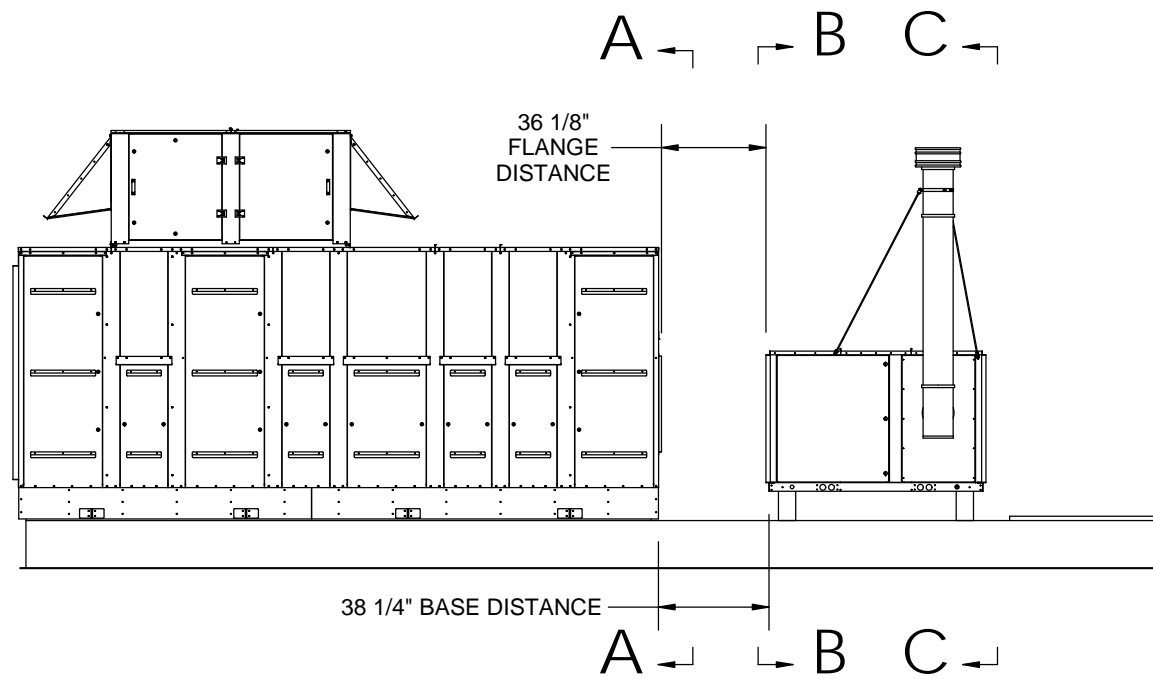

HEATER AND BLOWER CONNECTION SIZES										
HEATER SIZE	B1 ATLI 25-25	B1 ATZAF 25-25	B1 ATZAF 28-28	B1 ATZAF 32-32	B2	HW-1	HW-2	HW-3	HH	HH-2
HF550	40	39 3/4	40 5/8	39 7/8	43 1/2	85	61	2 5/8	44	35 1/8
HF750	40	39 3/4	40 5/8	39 7/8	43 1/2	93	69	2 5/8	44 1/4	35 1/4
HF1000	40	39 7/8	40 1/2	40 1/4	43 1/2	99	75	2 5/8	50	38 1/8
HF1250	40	39 7/8	40 1/2	40 1/4	43 1/2	99	75	2 5/8	50	38 1/8
HF1500	40	39 7/8	40 1/2	40 1/4	43 1/2	142	107	2 5/8	50	38 1/8
HF1750	40	39 7/8	40 1/2	40 1/4	43 1/2	142	107	2 5/8	50	38 1/8
HF2000	40	39 7/8	40 1/2	40 1/4	43 1/2	152	117	2 5/8	50	38 1/8

Desert Aire has a policy of continuous product and quality improvement. Specifications and dimensions are subject to change without notice. This drawing and information contained herein are the exclusive property of the Desert Aire Corporation. Any use detrimental to the interests of Desert Aire is prohibited.

All Dimensions in Inches  
All Angles 90°  
All outside corners 0.125" fillet  
Unless Otherwise Specified

Tolerance Unless Otherwise Specified  
X.X ±.125  
X.XX ±.060  
X.XXX ±.030  
Angles ±1°

**DESERT AIRE**  
N120 W18485 FREISTADT RD  
GERMANTOWN, WI 53022  
Tel: (262) 946-7400  
Fax: (262) 946-7401

Third Angle Projection

ALL DIMENSIONS ARE IN INCHES  
TOLERANCE ± 1/8"

Part weight

Drawn: MHB  
Date Released: 4/8/2015  
Sheet: 2/6  
Scale: NTS

Description: GA SA 60T GAS HTR ADDENDUM  
Page Title: BLOWER & HEATER CONNECTIONS  
Rev.: 0  
Drawing Number: G900-003-G

HS-Q  
SUPPORT QTY  
CENTER OMITTED  
IF LESS THAN 3.

HEATER CONNECTION SIZES					
CURB PN	HEATER SIZE	HS-W	HS-Q	HS-L	CL
CB-LNBX-XX-0550	HF550	71 1/4	2	53 1/2	313 3/4
CB-LNBX-XX-0750	HF750	75 1/4	2	67 1/2	327 3/4
CB-LNBX-XX-1000	HF1000	78 1/4	2	73 1/2	333 3/4
CB-LNBX-XX-1250	HF1250	78 1/4	2	79 1/2	339 3/4
CB-LNBX-XX-1500	HF1500	82	3	79 1/2	339 3/4
CB-LNBX-XX-1750	HF1750	82	3	79 1/2	339 3/4
CB-LNBX-XX-2000	HF2000	82	3	89 1/2	349 3/4

CURB HEIGHT IN INCHES DESIGNATED BY XX IN THE CURB PART NUMBER

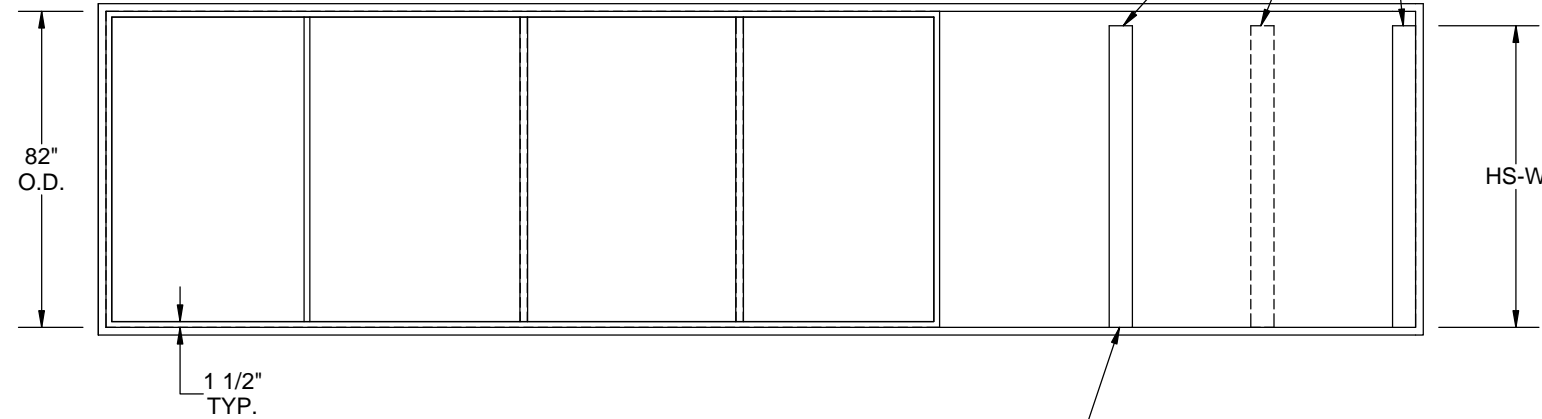

HEATER SUPPORT ARE ALWAYS  
FLUSH WITH RIGHT EDGE OF CURB

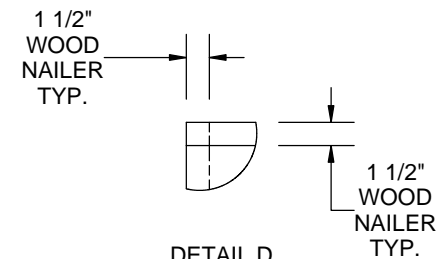
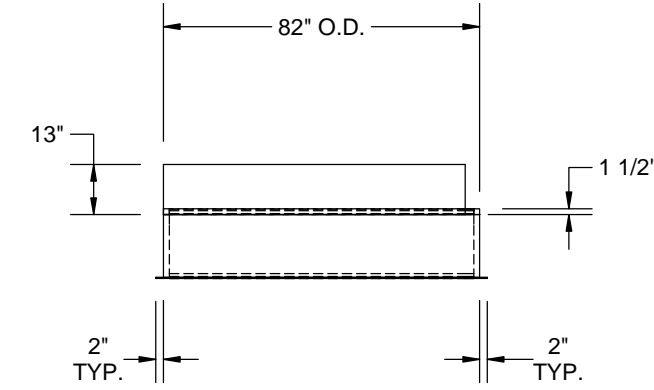
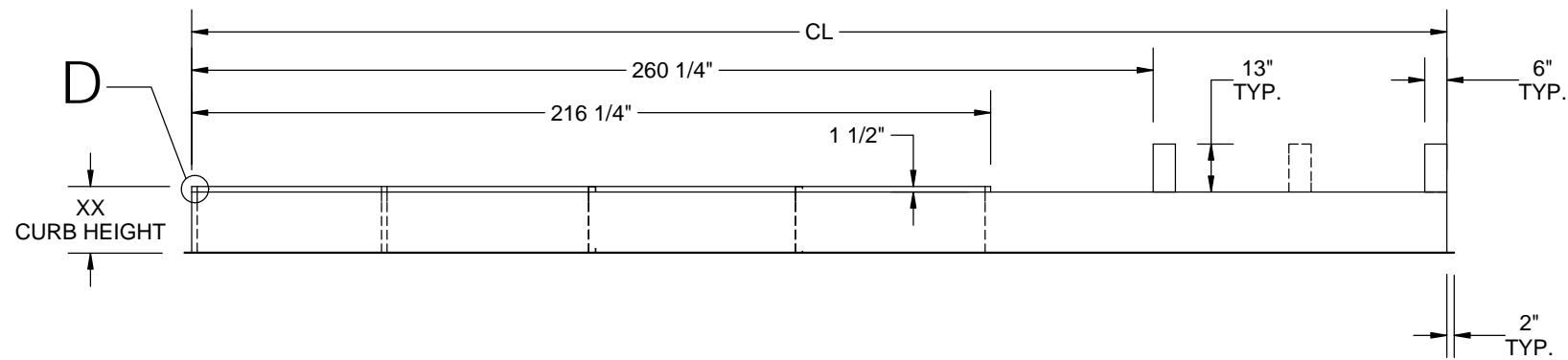

DETAIL D  
SCALE 1 : 12

- NOTES:
1. GALVANIZED STEEL CONSTRUCTION.
  2. FULLY WELDED WATERTIGHT ONE PIECE CURB.
  3. PRIME PAINTED AFTER FABRICATION.
  4. THE CURB HAS 1-1/2\"
  5. INTERNAL ANGLE REINFORCEMENT.
  6. CURB TO BE CURBS PLUS INC. CPC-3 STYLE.

Desert Aire has a policy of continuous product and quality improvement. Specifications and dimensions are subject to change without notice. This drawing and information contained herein are the exclusive property of the Desert Aire Corporation. Any use detrimental to the interests of Desert Aire is prohibited.

All Dimensions in Inches  
All Angles 90°  
All outside corners 0.125\"

Tolerance Unless  
Otherwise Specified  
X.X ±.125  
X.XX ±.060  
X.XXX ±.030  
Angles ±1°

N120 W18485 FREISTADT RD  
GERMANTOWN, WI 53022  
Tel: (262) 946-7400  
Fax: (262) 946-7401

Third Angle Projection

ALL DIMENSIONS ARE IN INCHES  
TOLERANCE ± 1/8"

Part weight

Drawn	Date Released
MHB	4/8/2015
Sheet	3/6
Scale	NTS
Rev.	0

Description	GA SA 60T GAS HTR ADDENDUM
Page Title	END DISCHARGE
Drawing Number	G900-003-G

HEATER CONNECTION SIZES								
CURB PN	HEATER SIZE	HS-W	HS-Q	HS-L	CL	SA-W (O.D.)	SA-L (O.D.)	SA-S1
CB-LNBY-XX-0550	HF550	71 1/4	2	53 1/2	376 1/4	63	50	9 1/2
CB-LNBY-XX-0750	HF750	75 1/4	2	67 1/2	390 1/4	63	50	9 1/2
CB-LNBY-XX-1000	HF1000	78 1/4	2	73 1/2	396 1/4	63	50	9 1/2
CB-LNBY-XX-1250	HF1250	78 1/4	2	79 1/2	402 1/4	63	50	9 1/2
CB-LNBY-XX-1500	HF1500	82	3	79 1/2	402 1/4	82	50	NA
CB-LNBY-XX-1750	HF1750	82	3	79 1/2	402 1/4	82	50	NA
CB-LNBY-XX-2000	HF2000	82	3	89 1/2	412 1/4	82	50	NA

CURB HEIGHT IN INCHES DESIGNATED BY XX IN THE CURB PART NUMBER

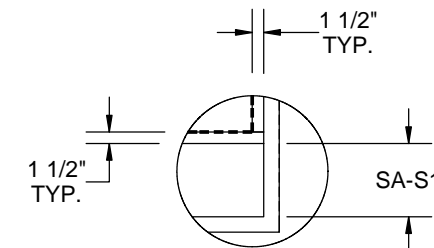
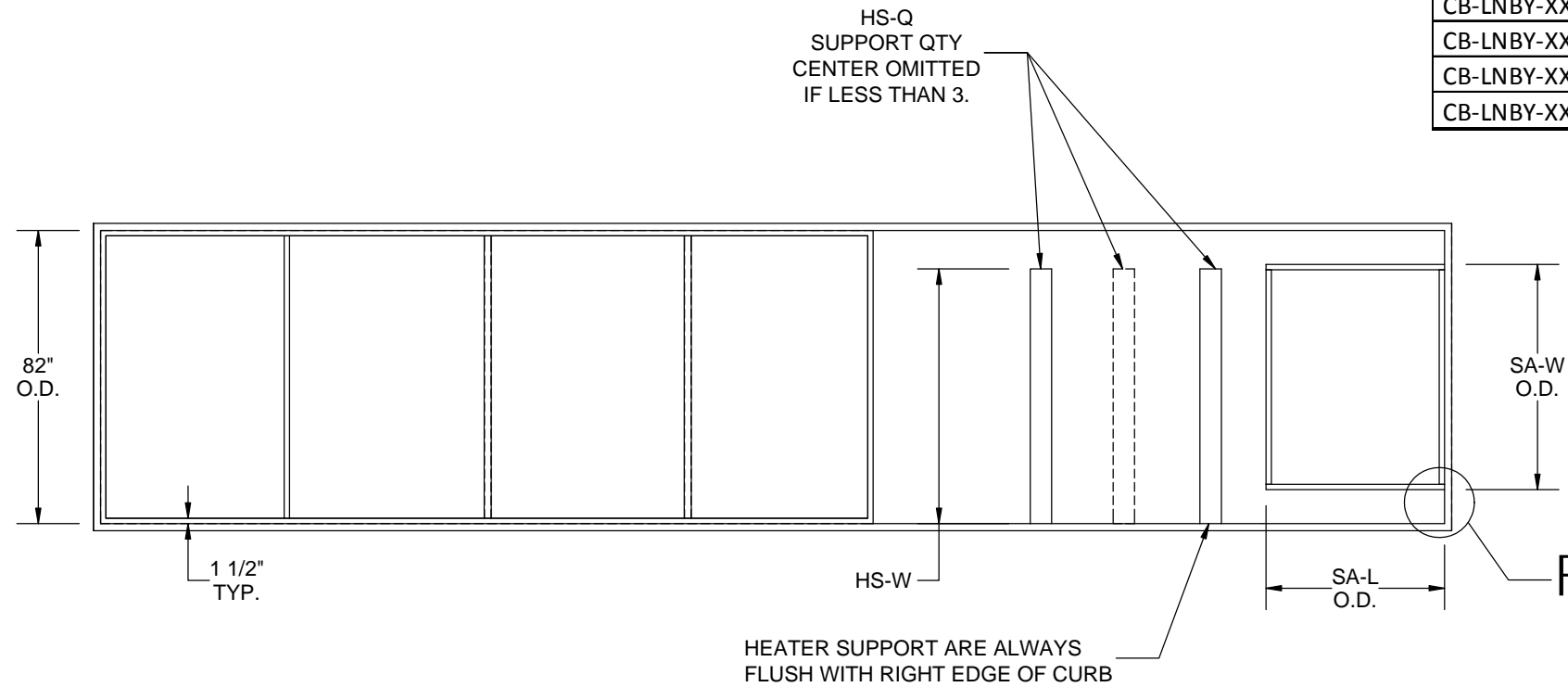

DETAIL F  
SCALE 1 : 24

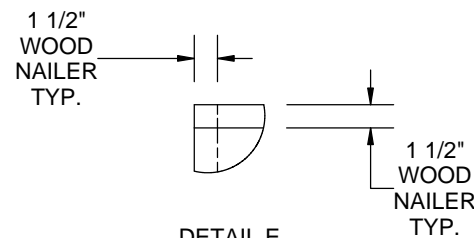
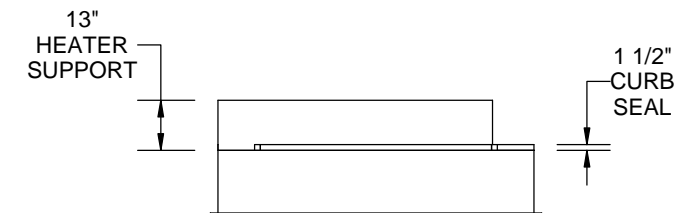
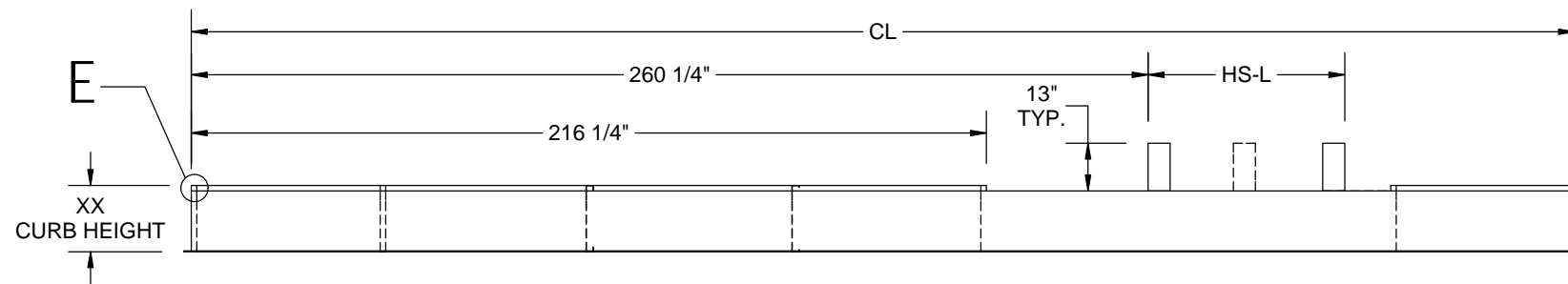

DETAIL E  
SCALE 1 : 12

- NOTES:
1. GALVANIZED STEEL CONSTRUCTION.
  2. FULLY WELDED WATERTIGHT ONE PIECE CURB.
  3. PRIME PAINTED AFTER FABRICATION.
  4. THE CURB HAS 1-1/2" THICK 3LB/FT<sup>3</sup> FIBERGLASS PERIMETER INSULATION.
  5. INTERNAL ANGLE REINFORCEMENT.
  6. CURB TO BE CURBS PLUS INC. CPC-3 STYLE.

Desert Aire has a policy of continuous product and quality improvement. Specifications and dimensions are subject to change without notice. This drawing and information contained herein are the exclusive property of the Desert Aire Corporation. Any use detrimental to the interests of Desert Aire is prohibited.	All Dimensions in Inches All Angles 90° All outside corners 0.125" fillet Unless Otherwise Specified	Tolerance Unless Otherwise Specified X.X ±.125 X.XX ±.060 X.XXX ±.030 Angles ±1°	<p>N120 W18485 FREISTADT RD GERMANTOWN, WI 53022 Tel: (262) 946-7400 Fax: (262) 946-7401</p>
ALL DIMENSIONS ARE IN INCHES TOLERANCE ± 1/8"	Third Angle Projection	Sheet: 4/6	Page Title: DOWN DISCHARGE CURB
Part weight	Scale: NTS	Rev.: 0	Drawing Number: G900-003-G

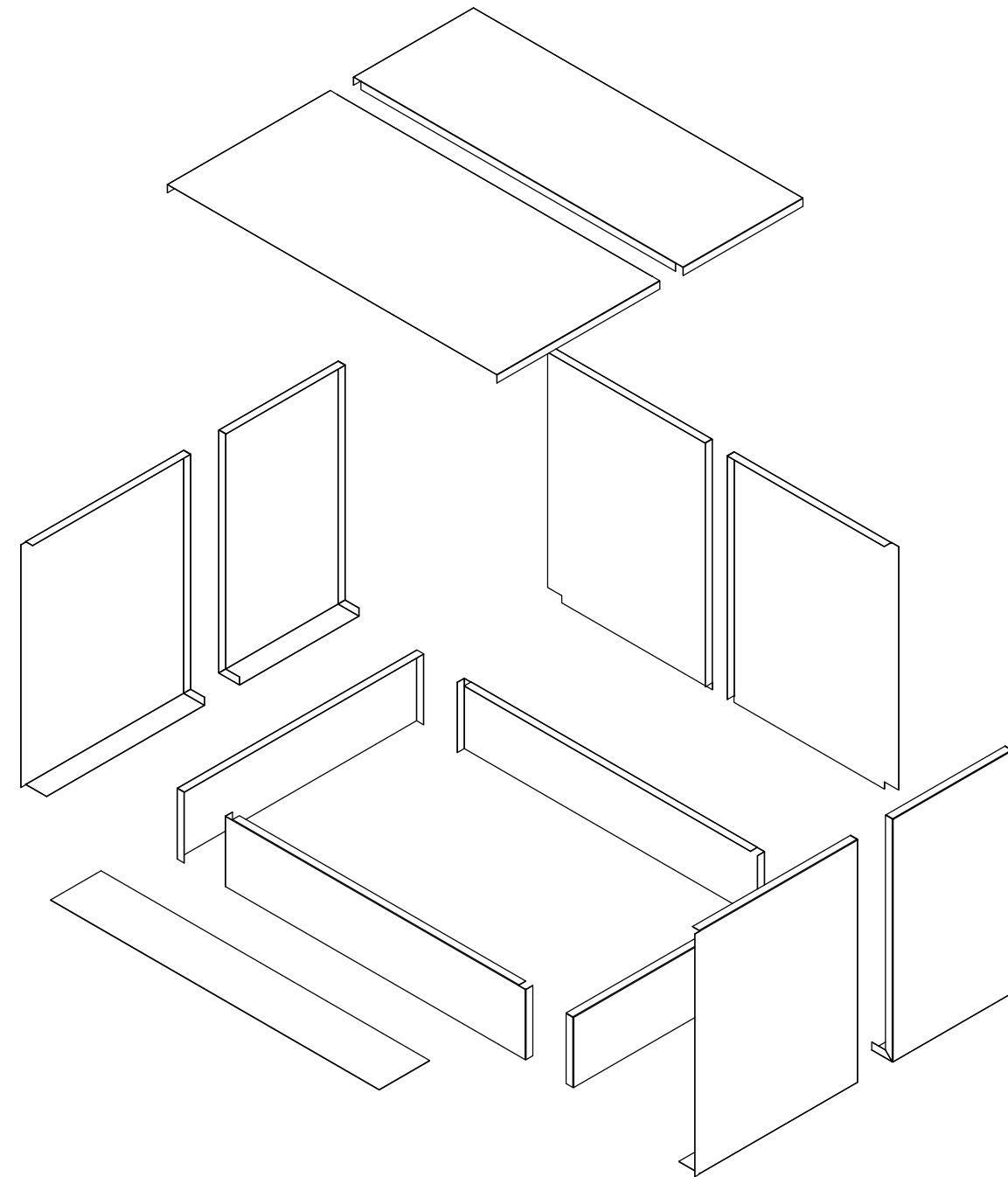
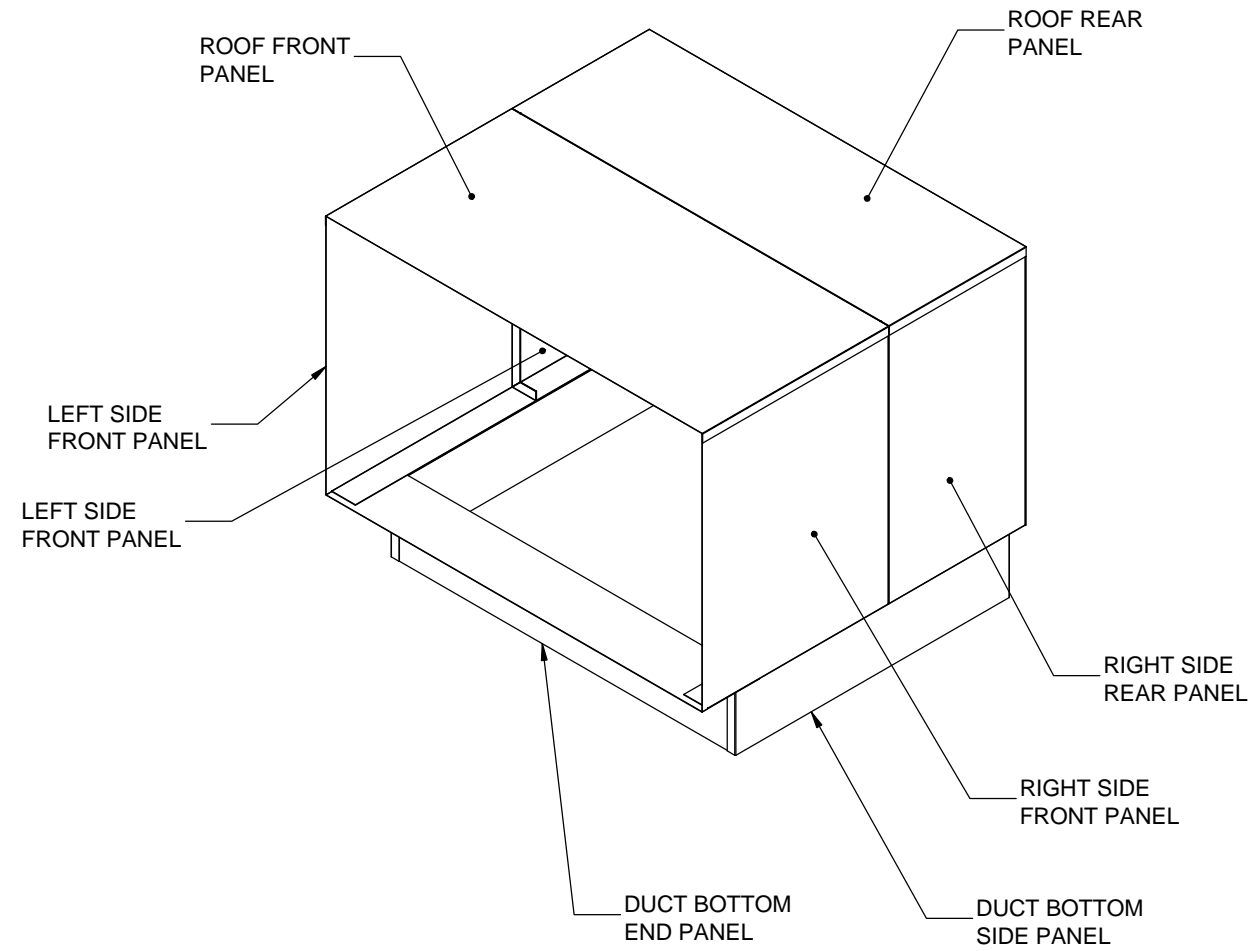

DUCT TRANSITION BY OTHERS.  
 DUCT ASSEMBLY IS FOR REFERENCE ONLY!  
 ALTERNATE CONSTRUCTION IS ACCEPTABLE.

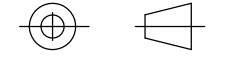
Desert Aire has a policy of continuous product and quality improvement. Specifications and dimensions are subject to change without notice. This drawing and information contained herein are the exclusive property of the Desert Aire Corporation. Any use detrimental to the interests of Desert Aire is prohibited.	All Dimensions in Inches All Angles 90° All outside corners 0.125" fillet Unless Otherwise Specified	Tolerance Unless Otherwise Specified X.X ±.125 X.XX ±.060 X.XXX ±.030 Angles ±1°	 N120 W18485 FREISTADT RD GERMANTOWN, WI 53022 Tel: (262) 946-7400 Fax: (262) 946-7401
	 Third Angle Projection	Drawn: MHB Date Released: 4/8/2015	
ALL DIMENSIONS ARE IN INCHES TOLERANCE ± 1/8"	Part weight	Sheet: 5/6 Scale: NTS Rev.: 0	Drawing Number: G900-003-G

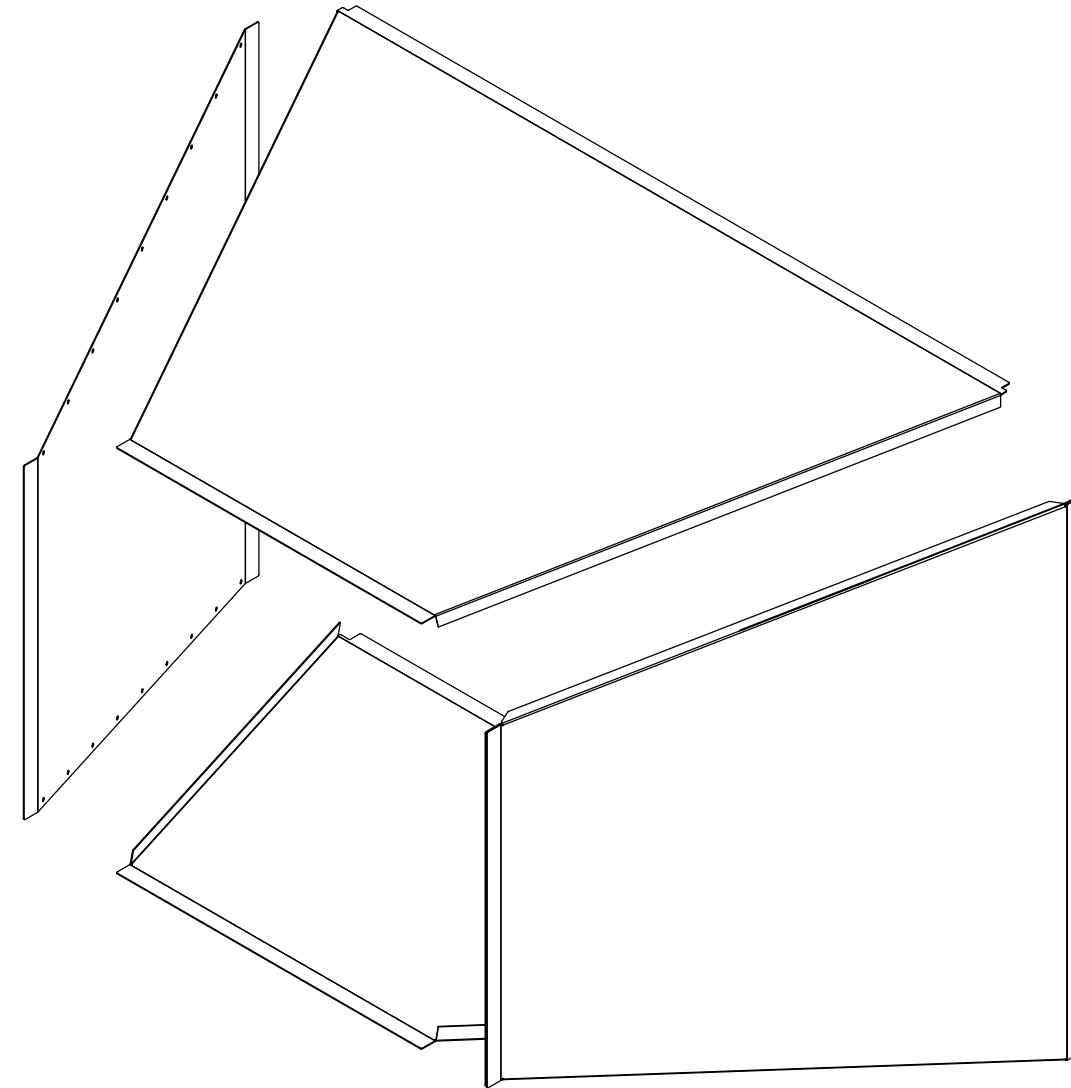
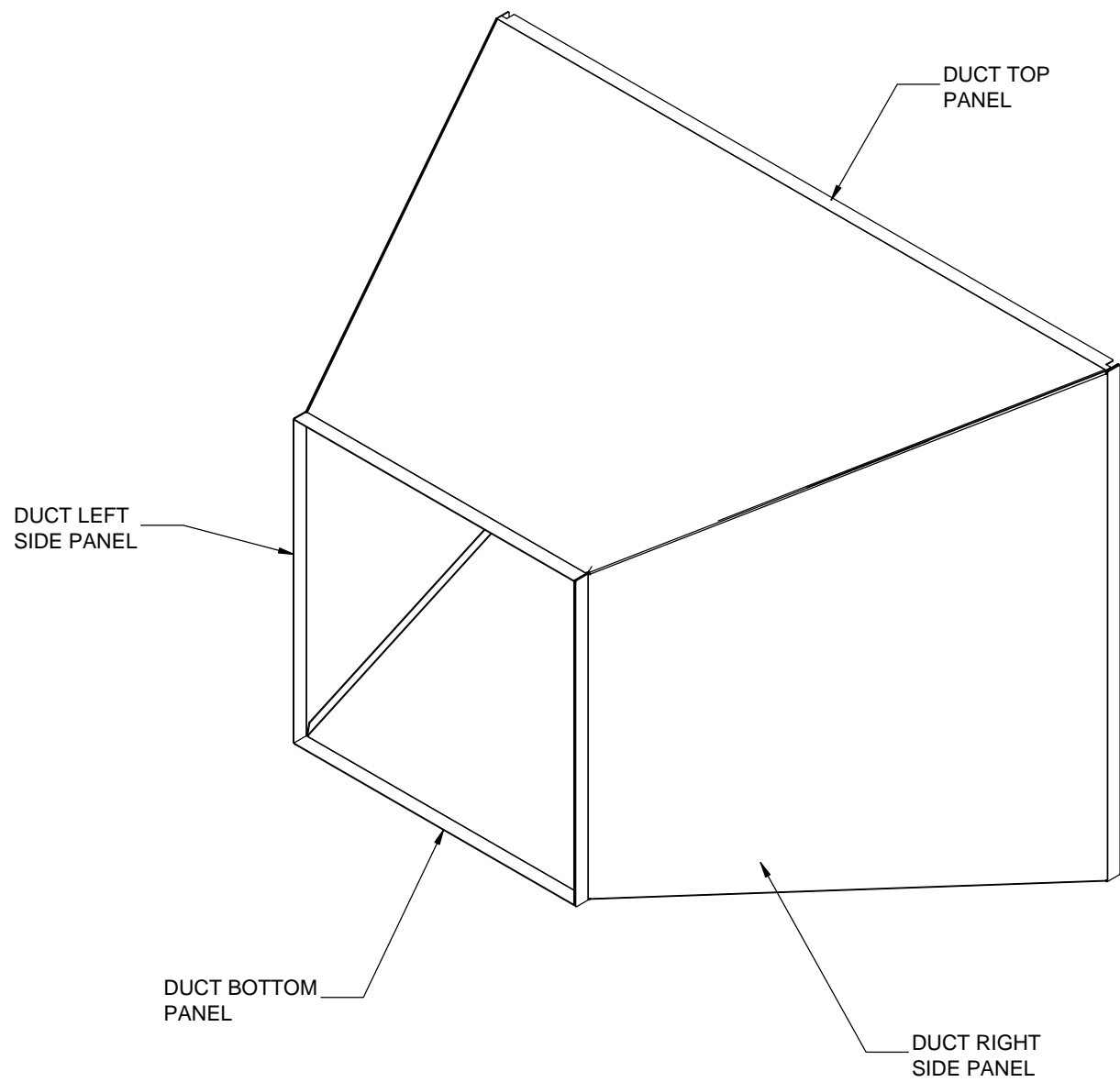

DUCT TRANSITION BY OTHERS.  
 DUCT ASSEMBLY IS FOR REFERENCE ONLY!  
 ALTERNATE CONSTRUCTION IS ACCEPTABLE.

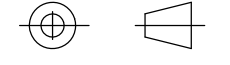
Desert Aire has a policy of continuous product and quality improvement. Specifications and dimensions are subject to change without notice. This drawing and information contained herein are the exclusive property of the Desert Aire Corporation. Any use detrimental to the interests of Desert Aire is prohibited.	All Dimensions in Inches All Angles 90° All outside corners 0.125" fillet Unless Otherwise Specified	Tolerance Unless Otherwise Specified X.X ±.125 X.XX ±.060 X.XXX ±.030 Angles ±1°	 N120 W18485 FREISTADT RD GERMANTOWN, WI 53022 Tel: (262) 946-7400 Fax: (262) 946-7401	
			Drawn: <b>MHB</b> Date Released: <b>4/8/2015</b>	Description: <b>GA SA 60T GAS HTR ADDENDUM</b>
ALL DIMENSIONS ARE IN INCHES TOLERANCE ± 1/8"	Third Angle Projection 	Sheet: <b>6/6</b>	Page Title: <b>UNIT TO HEATER DUCT</b>	
Part weight	Scale: <b>NTS</b>	Rev.: <b>0</b>	Drawing Number: <b>G900-003-G</b>	