

G900-002-G

HEATER SIZE	RL	HL	HL-C	HL-1	HH-C	HW	NPT DIA.
HF400	165 1/4	322 3/4	37 1/2	60	8 1/4	99 1/4	1
HF550	165 1/4	322 3/4	38 1/4	60	7 1/8	99 1/4	1 1/4
HF750	165 1/4	336 3/4	43 3/8	74	8 1/8	103 1/4	1 1/4
HF1000	165 1/4	342 3/4	45	80	8 3/8	106 1/4	1 1/2
HF1250	165 1/4	348 3/4	45	86	8 3/8	106 1/4	1 1/2
HF1500	165 1/4	348 3/4	50 1/2	86	9 1/8	142	2
HF1750	165 1/4	348 3/4	44 1/2	86	9 1/8	142	2
HF2000	165 1/4	358 3/4	67 3/4	96	9 1/2	152	2

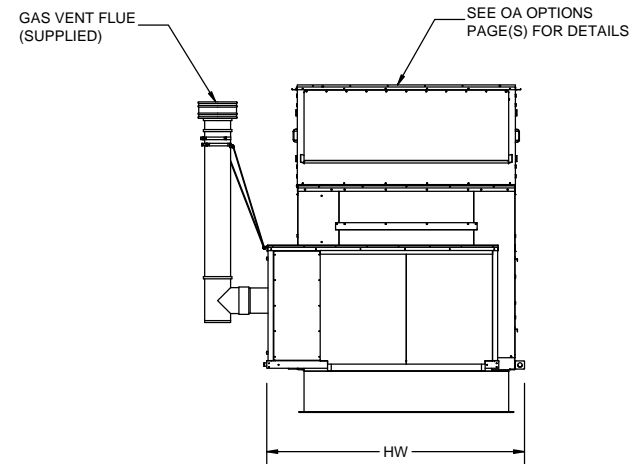
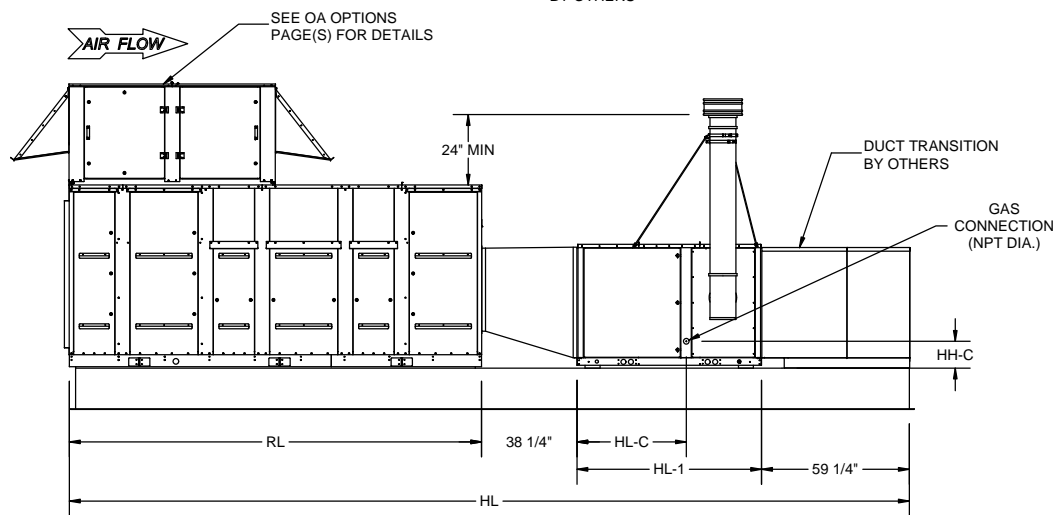
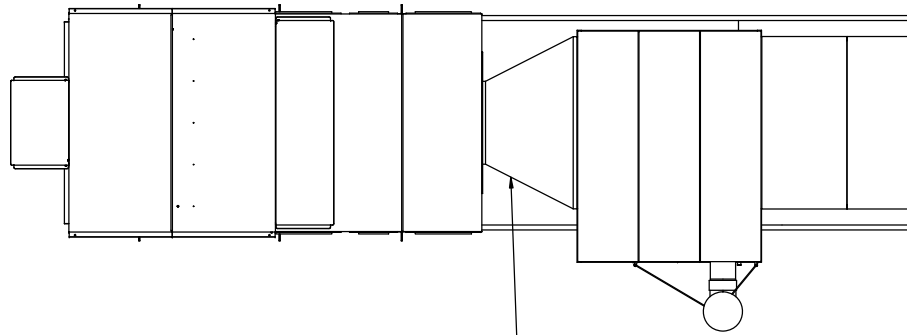

NOTE:
CONSULT MAIN GENERAL ARRANGEMENT DRAWING FOR UNIT SPECIFIC DIMENSIONS.
CONSULT FACTORY FOR INDOOR APPLICATIONS.

Desert Aire has a policy of continuous product and quality improvement. Specifications and dimensions are subject to change without notice. This drawing and information contained herein are the exclusive property of the Desert Aire Corporation. Any use detrimental to the interests of Desert Aire is prohibited.	All Dimensions in Inches All Angles 90° All outside corners 0.125" fillet Unless Otherwise Specified	Tolerance Unless Otherwise Specified X.X ±.125 X.XX ±.060 X.XXX ±.030 Angles ±1°	N120 W18485 FREISTADT RD GERMANTOWN, WI 53022 Tel: (262) 946-7400 Fax: (262) 946-7401
ALL DIMENSIONS ARE IN INCHES TOLERANCE ± 1/8"		Third Angle Projection	Sheet: 1/6 Scale: NTS
		Rev: 0	Page Title: OVERVIEW Drawing Number: G900-002-G

G900-002-G

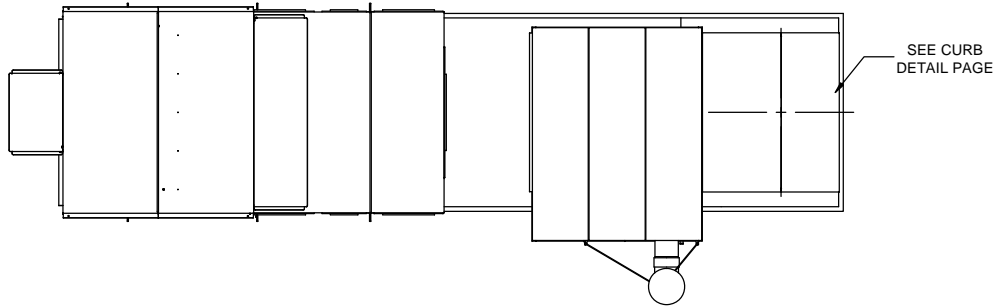

NOTE:
DUCT TRANSITION BY OTHERS
REMOVED FOR CLARITY.

A ← → B C ←

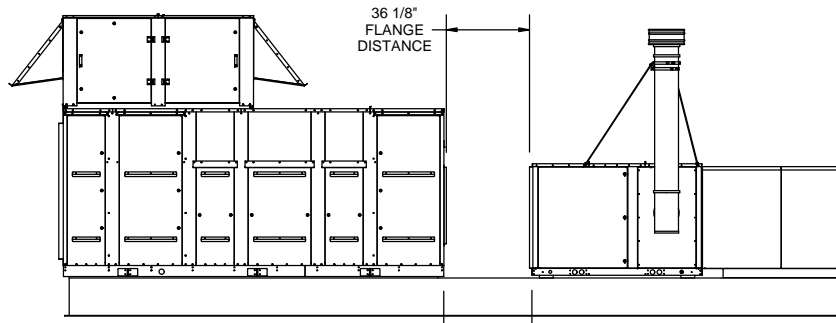

38 1/4" BASE DISTANCE

A ← → B C ←

35-50 TON										
BLOWER	BH	BW	B1 HF400	B1 HF550	B1 HF750	B1 HF1000	B1 HF1250	B1 HF1500	B1 HF1750	B1 HF2000
ATLI 18-18	20 3/8	23 1/2	25 7/8	28 5/8	28 5/8	31 7/8	31 7/8	31 7/8	31 7/8	31 7/8
ATLI 20-15	26 3/4	21 3/4	26 3/4	29 3/4	29 3/4	32 3/4	32 3/4	32 3/4	32 3/4	32 3/4
ATLI 22-22	29 3/4	29 3/4	27 1/4	30 1/4	30 1/4	33 1/4	33 1/4	33 1/4	33 1/4	33 1/4
ATLI 25-25	33 1/8	33 1/8	27 7/8	30 7/8	30 7/8	33 7/8	33 7/8	33 7/8	33 7/8	33 7/8
ATZAF 22-22	29 3/4	29 3/4	27 1/4	30 1/4	30 1/4	33 1/4	33 1/4	33 1/4	33 1/4	33 1/4
ATZAF 25-25	33 1/8	33 1/8	27 7/8	30 7/8	30 7/8	33 7/8	33 7/8	33 7/8	33 7/8	33 7/8
ATZAF 28-28	37	37	29 1/2	31 1/2	31 1/2	34 1/2	34 1/2	34 1/2	34 1/2	34 1/2

NOTE:
HEATER INLET AND OUTLET ARE THE SAME DIMENSIONS

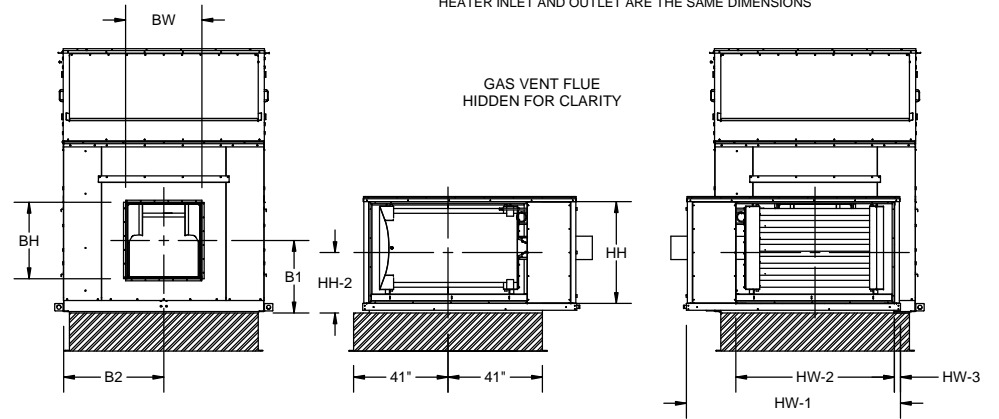

SECTION A-A
END OF UNIT

SECTION B-B
INTAKE OF HEATER

SECTION C-C
OUTLET OF HEATER

HEATER AND BLOWER CONNECTION SIZES						
HEATER SIZE	B2	HW-1	HW-2	HW-3	HH	HH-2
HF400	43 1/2	85	61	25/8	38	23 1/8
HF550	43 1/2	85	61	25/8	44	26 1/8
HF750	43 1/2	93	69	25/8	44 1/4	26 1/4
HF1000	43 1/2	99	75	25/8	50	29 1/8
HF1250	43 1/2	99	75	25/8	50	29 1/8
HF1500	43 1/2	142	107	25/8	50	29 1/8
HF1750	43 1/2	142	107	25/8	50	29 1/8
HF2000	43 1/2	152	117	25/8	50	29 1/8

Desert Aire has a policy of continuous product and quality improvement. Specifications and dimensions are subject to change without notice. This drawing and information contained herein are the exclusive property of the Desert Aire Corporation. Any use detrimental to the interests of Desert Aire is prohibited.

All Dimensions in Inches
All Angles 90°
All outside corners 0.125" fillet
Unless Otherwise Specified

Tolerance Unless
Otherwise Specified
X.X ±.125
X.XX ±.060
X.XXX ±.030
Angles ±1°



N120 W18485 FREISTADT RD
GERMANTOWN, WI 53022
Tel: (262) 946-7400
Fax: (262) 946-7401

Third Angle Projection

Drawn MHB Date Released 4/8/2015

Description GA SA 35-50T GAS HTR

ALL DIMENSIONS ARE IN INCHES
TOLERANCE ± 1/8"

Part weight

Scale 2/6

Page Title BLOWER & HEATER CONNECTIONS

Rev. 0

Drawing Number G900-002-G

G900-002-G

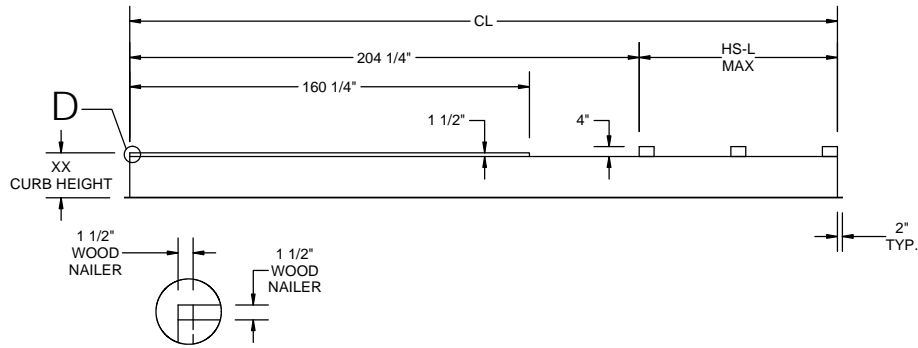
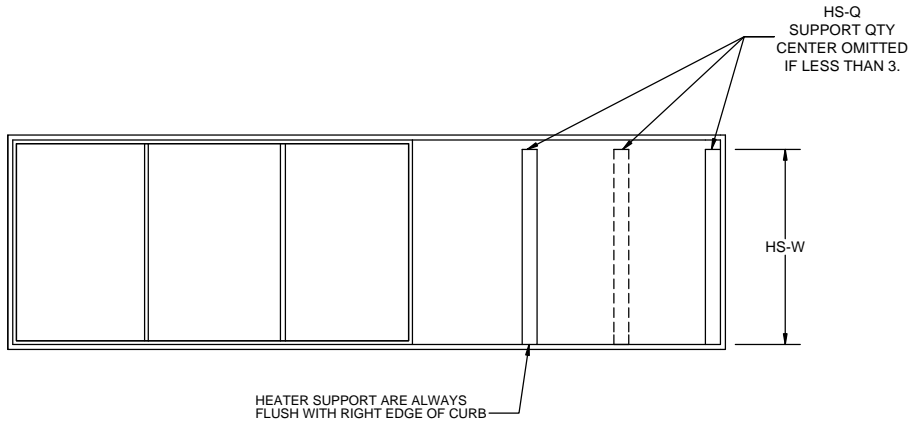



DETAIL D
SCALE 1 : 12

1. GALVANIZED STEEL CONSTRUCTION.
2. FULLY WELDED WATERTIGHT ONE PIECE CURB.
3. PRIME PAINTED AFTER FABRICATION.
4. THE CURB HAS 1-1/2" THICK 3LB/FT³ FIBERGLASS PERIMETER INSULATION.
5. INTERNAL ANGLE REINFORCEMENT AS NEEDED.
6. CURB TO BE CURBS PLUS INC. CPC-3 STYLE.

HEATER CURB CONNECTION SIZES					
CURB PN	HEATER SIZE	HS-W	HS-Q	HS-L	CL
CB-MNBX-XX-0400	HF400	71 1/4	2	53 1/2	257 3/4
CB-MNBX-XX-0550	HF550	71 1/4	2	53 1/2	257 3/4
CB-MNBX-XX-0750	HF750	75 1/4	2	67 1/2	271 3/4
CB-MNBX-XX-1000	HF1000	78 1/4	2	73 1/2	277 3/4
CB-MNBX-XX-1250	HF1250	78 1/4	2	79 1/2	283 3/4
CB-MNBX-XX-1500	HF1500	82	3	79 1/2	283 3/4
CB-MNBX-XX-1750	HF1750	82	3	79 1/2	283 3/4
CB-MNBX-XX-2000	HF2000	82	3	89 1/2	293 3/4

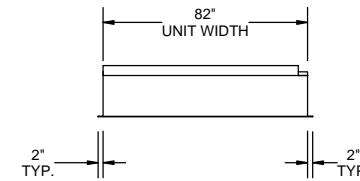
CURB HEIGHT IN INCHES DESIGNATED BY XX IN THE CURB PART NUMBER



Desert Aire has a policy of continuous product and quality improvement. Specifications and dimensions are subject to change without notice. This drawing and information contained herein are the exclusive property of the Desert Aire Corporation. Any use detrimental to the interests of Desert Aire is prohibited.	All Dimensions in Inches All Angles 90° All outside corners 0.125" fillet Unless Otherwise Specified	Tolerance Unless Otherwise Specified X.X ±.125 X.XX ±.060 X.XXX ±.030 Angles ±1°	 N120 W18485 FREISTADT RD GERMANTOWN, WI 53022 Tel: (262) 946-7400 Fax: (262) 946-7401
	Third Angle Projection	Drawn: MHB Date Released: 4/8/2015	
ALL DIMENSIONS ARE IN INCHES TOLERANCE ± 1/8"	Part weight	Sheet: 3/6 Scale: NTS	Page Title: END DISCHARGE Rev: 0 Drawing Number: G900-002-G

HEATER CONNECTION SIZES								
CURB PN	HEATER SIZE	HS-W	HS-Q	HS-L	CL	SA-W (O.D.)	SA-L (O.D.)	SA-S1
CB-MNBY-XX-0400	HF400	71 1/4	2	53 1/2	320 1/4	63	50	9 1/2
CB-MNBY-XX-0550	HF550	71 1/4	2	53 1/2	320 1/4	63	50	9 1/2
CB-MNBY-XX-0750	HF750	75 1/4	2	67 1/2	334 1/4	63	50	9 1/2
CB-MNBY-XX-1000	HF1000	78 1/4	2	73 1/2	340 1/4	63	50	9 1/2
CB-MNBY-XX-1250	HF1250	78 1/4	2	79 1/2	346 1/4	63	50	9 1/2
CB-MNBY-XX-1500	HF1500	82	3	79 1/2	346 1/4	82	50	NA
CB-MNBY-XX-1750	HF1750	82	3	79 1/2	346 1/4	82	50	NA
CB-MNBY-XX-2000	HF2000	82	3	89 1/2	356 1/4	82	50	NA

CURB HEIGHT IN INCHES DESIGNATED BY XX IN THE CURB PART NUMBER

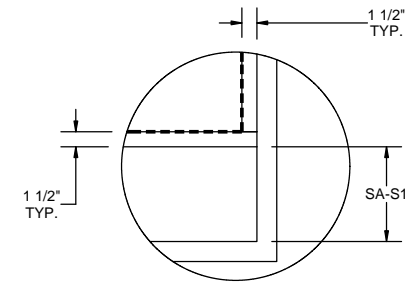
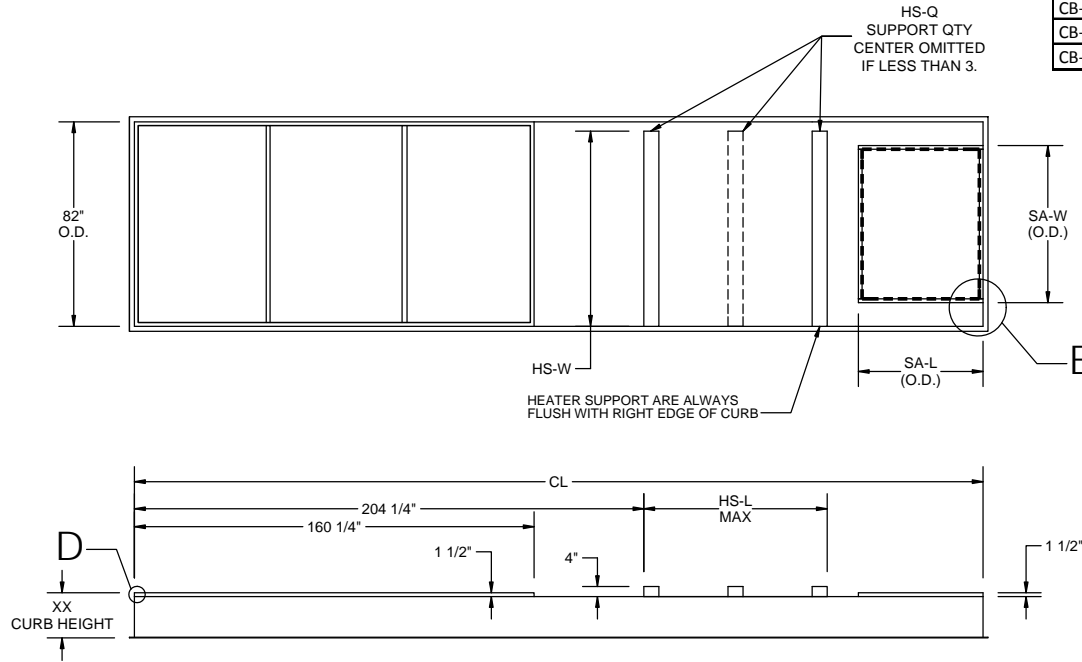

DETAIL E
SCALE 1 : 12

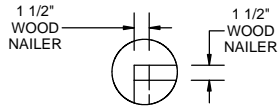
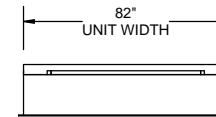

DETAIL D
SCALE 1 : 12

1. GALVANIZED STEEL CONSTRUCTION.
2. FULLY WELDED WATERTIGHT ONE PIECE CURB.
3. PRIME PAINTED AFTER FABRICATION.
4. THE CURB HAS 1-1/2" THICK 3LB/FT³ FIBERGLASS PERIMETER INSULATION.
5. INTERNAL ANGLE REINFORCEMENT AS NEEDED.
6. CURB TO BE CURBS PLUS INC. CPC-3 STYLE.

Desert Aire has a policy of continuous product and quality improvement. Specifications and dimensions are subject to change without notice. This drawing and information contained herein are the exclusive property of the Desert Aire Corporation. Any use detrimental to the interests of Desert Aire is prohibited.	All Dimensions in Inches All Angles 90° All outside corners 0.125" fillet Unless Otherwise Specified	Tolerance Unless Otherwise Specified X.X ±.125 X.XX ±.060 X.XXX ±.030 Angles ±1°	N120 W18485 FREISTADT RD GERMANTOWN, WI 53022 Tel: (262) 946-7400 Fax: (262) 946-7401
	Third Angle Projection	Drawn: MHB Date Released: 4/8/2015	
ALL DIMENSIONS ARE IN INCHES TOLERANCE ± 1/8"	Sheet: 4/6	Scale: NTS	Page Title: DOWN DISCHARGE Rev.: 0 Drawing Number: G900-002-G

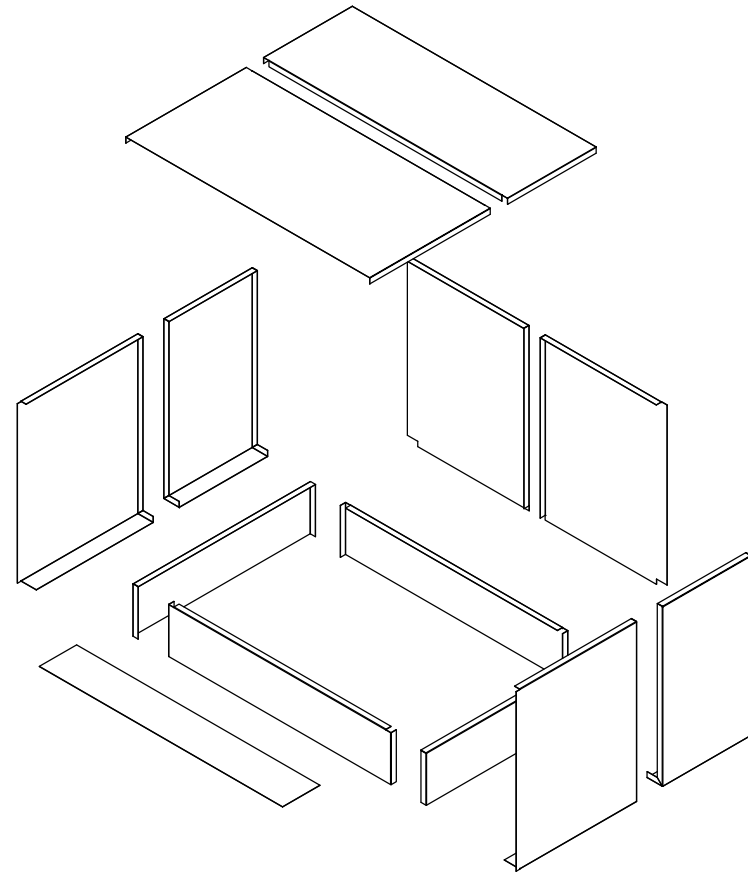
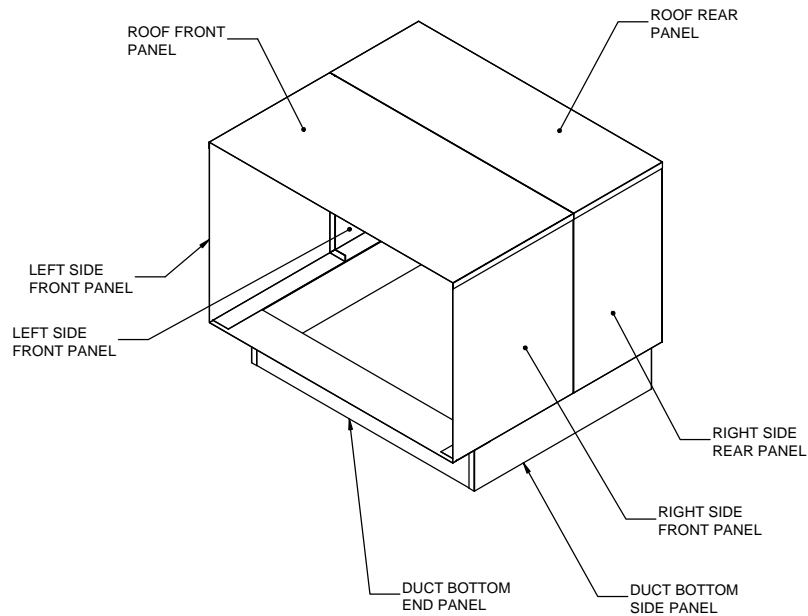

DUCT TRANSITION BY OTHERS.
 DUCT ASSEMBLY IS FOR REFERENCE ONLY!
 ALTERNATE CONSTRUCTION IS ACCEPTABLE.

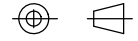
Desert Aire has a policy of continuous product and quality improvement. Specifications and dimensions are subject to change without notice. This drawing and information contained herein are the exclusive property of the Desert Aire Corporation. Any use detrimental to the interests of Desert Aire is prohibited.	All Dimensions in Inches All Angles 90° All outside corners 0.125" fillet Unless Otherwise Specified	Tolerance Unless Otherwise Specified X.X ±.125 X.XX ±.060 X.XXX ±.030 Angles ±1°	 N120 W18485 FREISTADT RD GERMANTOWN, WI 53022 Tel: (262) 946-7400 Fax: (262) 946-7401
	 Third Angle Projection	Drawn MHB Date Released 4/8/2015	
ALL DIMENSIONS ARE IN INCHES TOLERANCE ± 1/8"	Part weight	Sheet 5/6 Scale NTS	Page Title DOWN DISCHARGE DUCT Rev. 0 Drawing Number G900-002-G

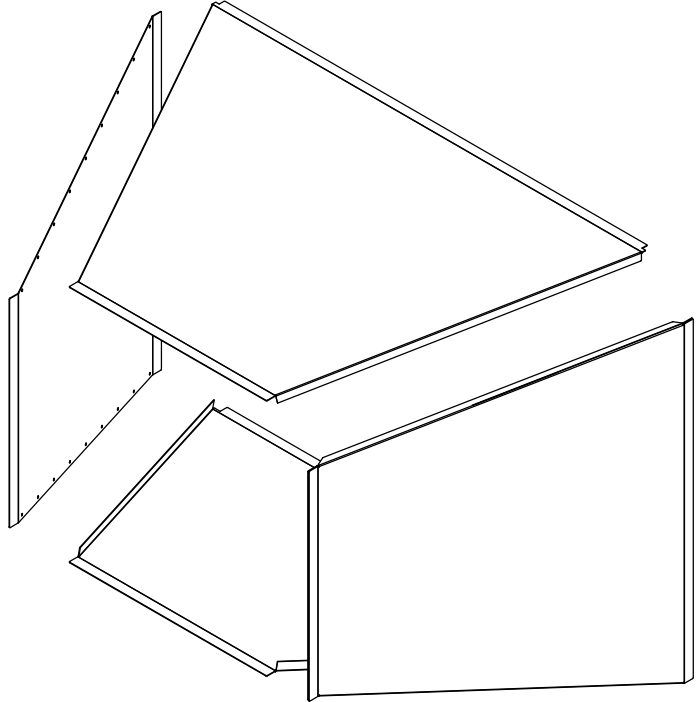
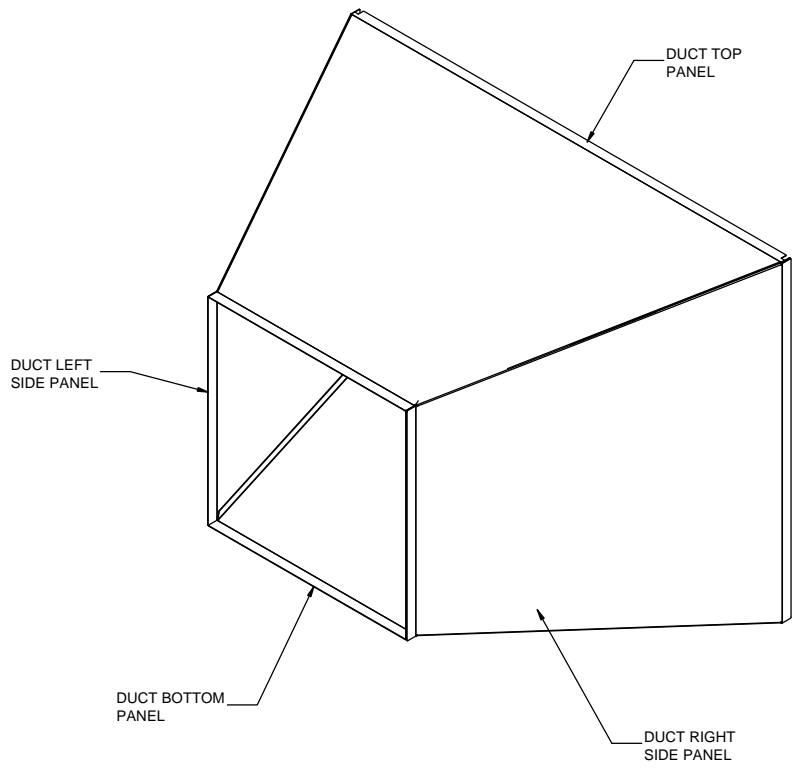

DUCT TRANSITION BY OTHERS.
 DUCT ASSEMBLY IS FOR REFERENCE ONLY!
 ALTERNATE CONSTRUCTION IS ACCEPTABLE.

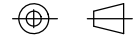
Desert Aire has a policy of continuous product and quality improvement. Specifications and dimensions are subject to change without notice. This drawing and information contained herein are the exclusive property of the Desert Aire Corporation. Any use detrimental to the interests of Desert Aire is prohibited.	All Dimensions in Inches All Angles 90° All outside corners 0.125" fillet Unless Otherwise Specified	Tolerance Unless Otherwise Specified X.X ±.125 X.XX ±.060 X.XXX ±.030 Angles ±1°	 N120 W18485 FREISTADT RD GERMANTOWN, WI 53022 Tel: (262) 946-7400 Fax: (262) 946-7401
	 Third Angle Projection	Drawn: MHB Date Released: 4/8/2015	
ALL DIMENSIONS ARE IN INCHES TOLERANCE ± 1/8"	Part weight	Sheet: 6/6 Scale: NTS	Page Title: UNIT TO HEATER DUCT Rev.: 0 Drawing Number: G900-002-G