

NON-VENTILATION UNIT SHOWN

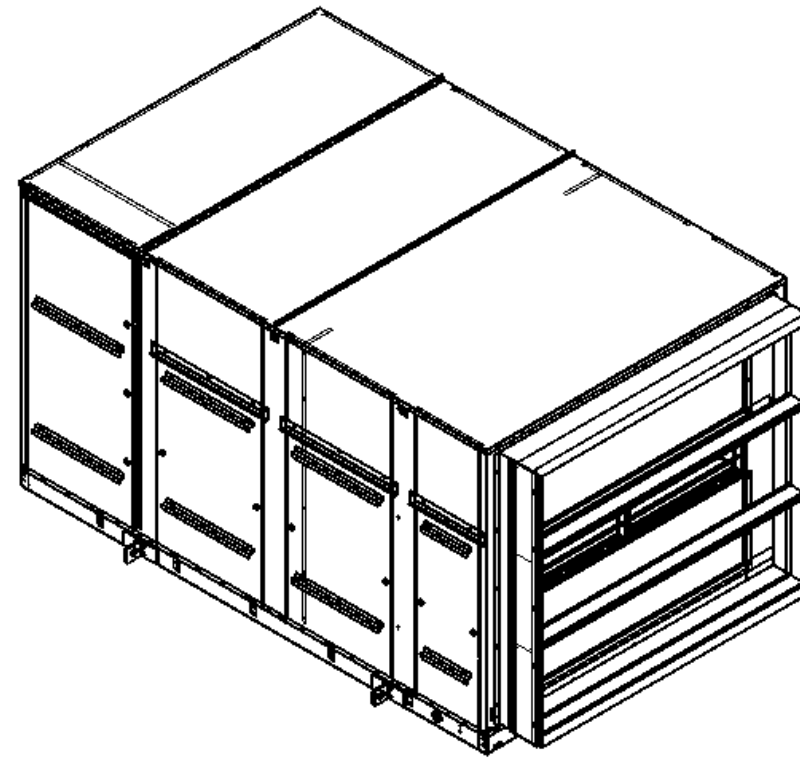

UNIT TYPE	MODEL SIZE	RL	L1	UH	H2	H3
WITHOUT ENERGY RECOVERY	18	120	131 1/8	49 1/8	40 3/8	5 7/8
	20	120	131 1/8	49 1/8	40 3/8	5 7/8
	24	120	131 1/8	59 1/8	48 3/8	5 7/8
	30	120	131 1/8	69 1/8	60 1/2	5 7/8
WITH ENERGY RECOVERY	18	153 3/8	164 1/2	49 1/8	40 3/8	6 1/2
	20	153 3/8	164 1/2	49 1/8	40 3/8	6 1/2
	24	153 3/8	164 1/2	59 1/8	48 3/8	6 1/2
	30	153 3/8	164 1/2	69 1/8	60 1/2	6 1/2

CAB	STANDARD RETURN					
	FILTER OPTION	MODEL SIZE	PART NUMBER	QTY	NOM WIDTH	NOM HEIGHT
DISPOSABLE	18	870-041	6	20	24	4
	20	870-041	6	20	24	4
	24	870-012	6	24	24	4
	30	870-041	9	20	24	4
DEACTIVATOR	18	872-006	6	20	24	2
		870-043	6			
	20	872-006	6	20	24	2
		870-043	6			
	24	872-010	6	24	24	2
		870-009	6			
	30	872-006	9	20	24	2
		870-043	9			

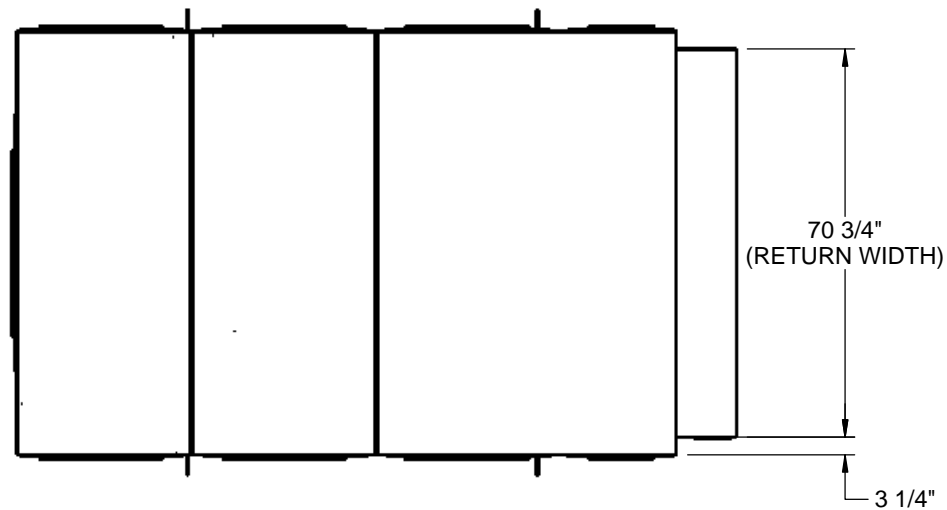
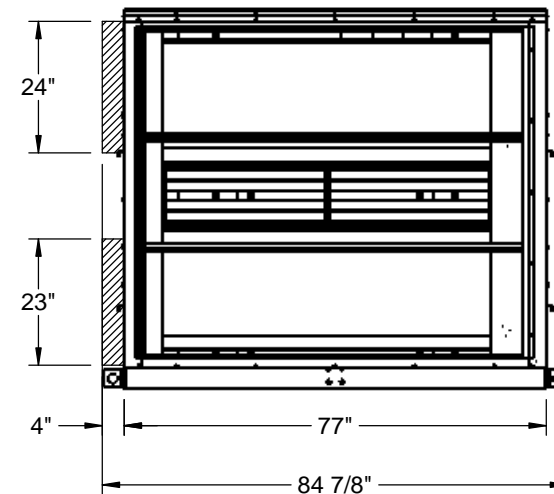
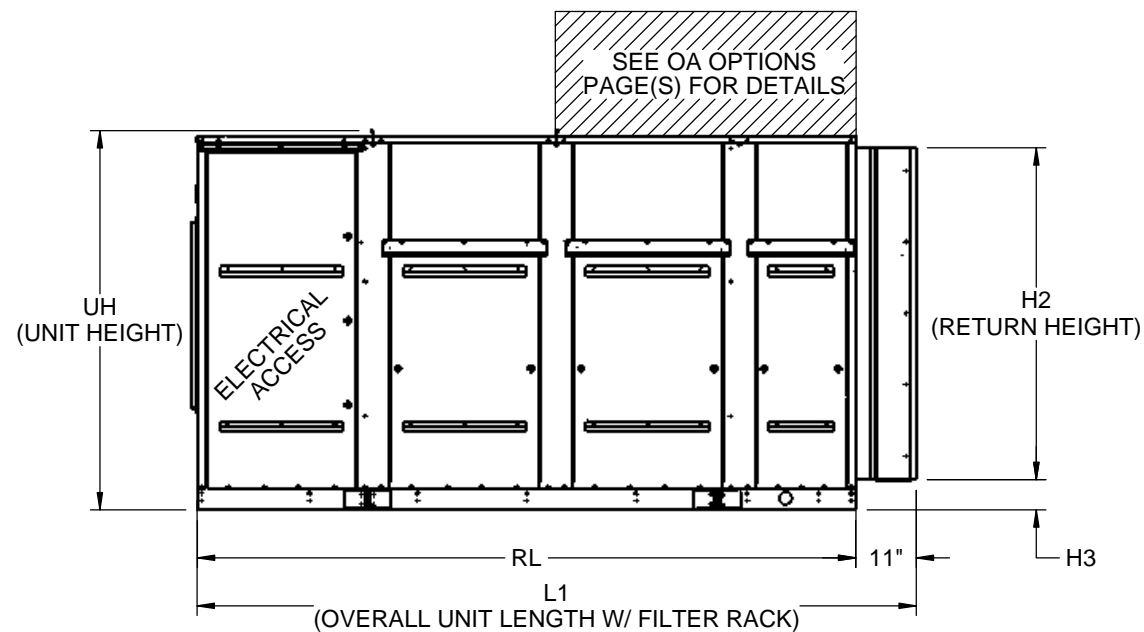

OPTIONAL OUTDOOR HOODS OMITTED FOR CLARITY
SEE OA BOX OPTION PAGES FOR DETAILED INFORMATION

GENERAL NOTES FOR APPLICABLE SHEETS:

- VIEWES ARE FOR PICTORAL PURPOSES.
- REFER TO SUBMITTAL FOR CUSTOMER CONNECTION LOCATIONS.
- DIMENSIONS ARE TO ACCESS SIDE OF UNIT.
- LH ACCESS SHOWN FOR DISPLAY PURPOSES. ACCESS DOOR CONFIGURATION MAY CHANGE DEPENDING ON UNIT SIZE OR TYPE
- REFER TO SHEET 4,5,6 FOR INTAKE AND DISCHARGE CONNECTION DIMENSIONS.

Desert Aire has a policy of continuous product and quality improvement. Specifications and dimensions are subject to change without notice. This drawing and information contained herein are the exclusive property of the Desert Aire Corporation. Any use detrimental to the interests of Desert Aire is prohibited.

All Dimensions in Inches
All Angles 90°
All outside corners 0.125" fillet
Unless Otherwise Specified

Tolerance Unless Otherwise Specified
X.X ±.125
X.XX ±.060
X.XXX ±.030
Angles ±1°

DESERT AIRE
N120 W18485 FREISTADT RD
GERMANTOWN, WI 53022
Tel: (262) 946-7400
Fax: (262) 946-7401

Third Angle Projection

Part weight

Drawn ASV	Date Released 12/5/2014	Description SA 18-30 TON STANDARD RETURN
Sheet 1/7	Page Title GENERAL INFORMATION	
Scale NTS	Rev. 0	Drawing Number G900-001

ALL DIMENSIONS ARE IN INCHES
FRACTIONAL TOLERANCE ± 1/8"

G900-001

ENERGY RECOVERY OPTION SHOWN

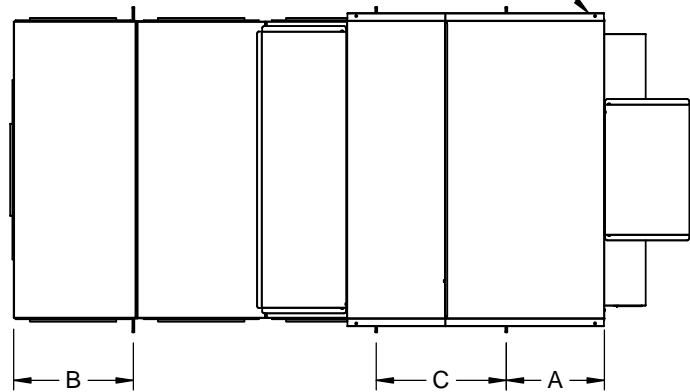

SEE TABLE FOR LIFTING LUG QUANTITY AND LOCATION

UNIT TYPE	MODEL SIZE	LUG QTY	LUG 1	LUG 2	LUG 3
			A	B	C
WITHOUT ENERGY RECOVERY	18	2	25 1/4	31	N/A
	20	2	25 1/4	31	N/A
	24	2	25 1/4	31	N/A
	30	2	25 1/4	31	N/A
WITH ENERGY RECOVERY	18	3	25 1/4	31	33 7/8
	20	3	25 1/4	31	33 7/8
	24	3	25 1/4	31	33 7/8
	30	3	25 1/4	31	33 7/8

UNIT TYPE	MODEL SIZE	D	POOL WATER		CIRCUIT A		CIRCUIT B	
			CIRCUIT A	CIRCUIT B	DISCH DIA	LIQUID DIA	DISCH DIA	LIQUID DIA
WITHOUT ENERGY RECOVERY	18	12 3/4	1 1/4	1 1/4	1 1/8	5/8	1 1/8	5/8
	20	12 3/4	1 1/4	1 1/4	1 1/8	3/4	1 1/8	3/4
	24	12 3/4	1 1/4	1 1/4	1 1/8	5/8	1 1/8	3/4
	30	12 3/4	1 1/2	1 1/2	1 1/8	3/4	1 1/8	3/4
WITH ENERGY RECOVERY	18	46 1/8	1 1/4	1 1/4	1 1/8	5/8	1 1/8	5/8
	20	46 1/8	1 1/4	1 1/4	1 1/8	3/4	1 1/8	3/4
	24	46 1/8	1 1/4	1 1/4	1 1/8	5/8	1 1/8	3/4
	30	46 1/8	1 1/2	1 1/2	1 1/8	3/4	1 1/8	3/4

OPTIONAL SIDE REMOTE CONDENSER CONNECTION LOCATION

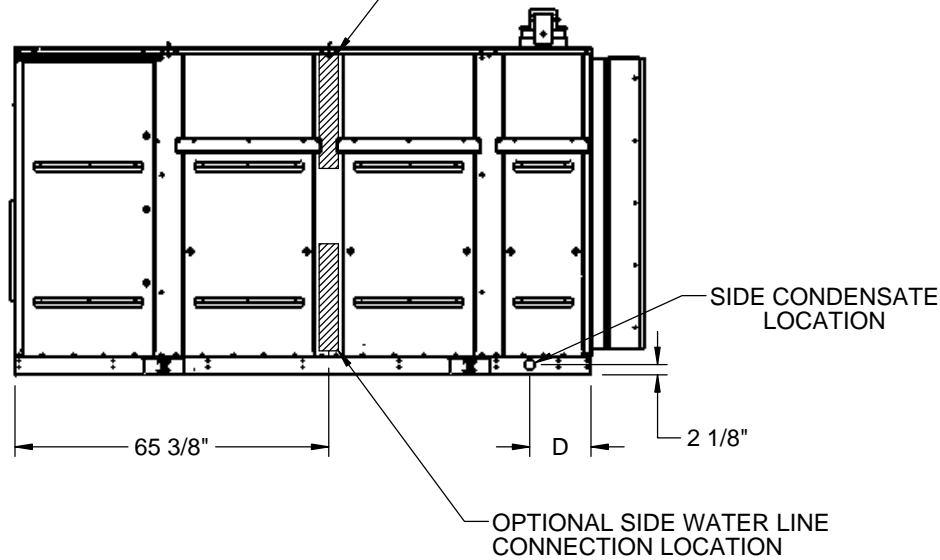

DUCT CONNECTION w/DAMPER OPTION SHOWN

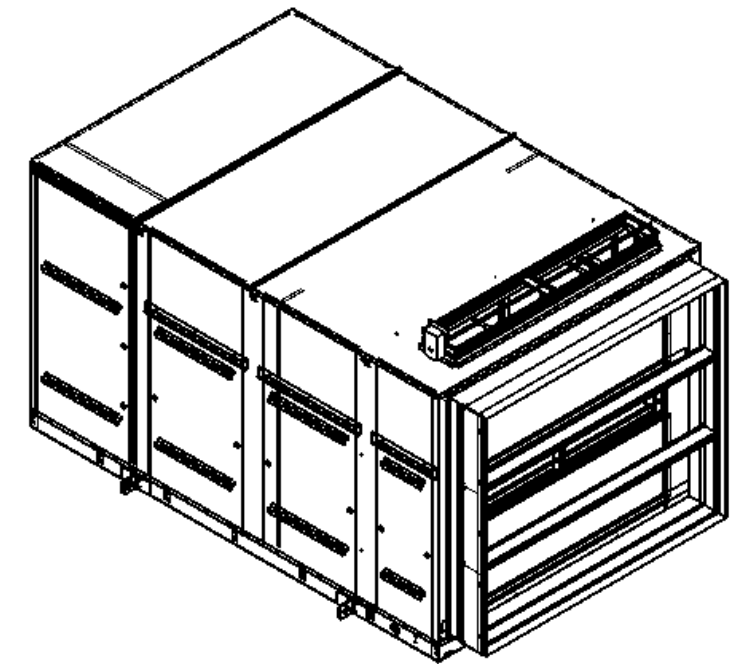
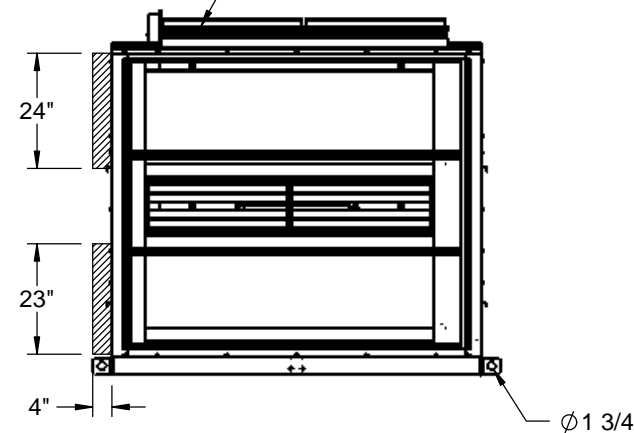

OPTIONAL SIDE WATER LINE CONNECTION LOCATION

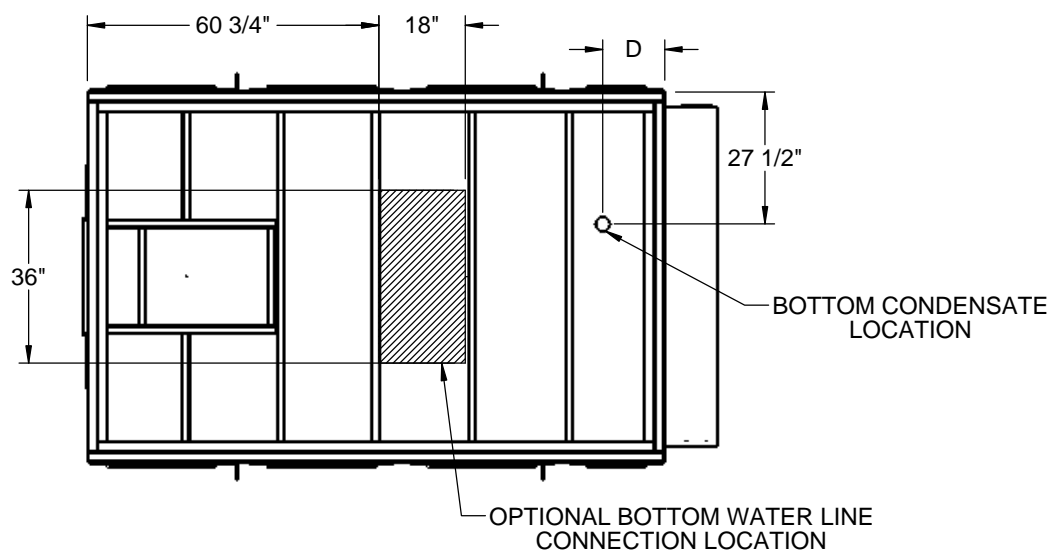

LEFT HAND CONNECTION OPTIONS SHOWN
RIGHT HAND CONNECTION OPTIONS LOCATED WITH SAME DIMENSIONS OPPOSITE SIDE WHEN SPECIFIED

Desert Aire has a policy of continuous product and quality improvement. Specifications and dimensions are subject to change without notice. This drawing and information contained herein are the exclusive property of the Desert Aire Corporation. Any use detrimental to the interests of Desert Aire is prohibited.	All Dimensions in Inches All Angles 90° All outside corners 0.125" fillet Unless Otherwise Specified	Tolerance Unless Otherwise Specified X.X ±.125 X.XX ±.060 X.XXX ±.030 Angles ±1°	N120 W18485 FREISTADT RD GERMANTOWN, WI 53022 Tel: (262) 946-7400 Fax: (262) 946-7401
ALL DIMENSIONS ARE IN INCHES FRACTIONAL TOLERANCE ± 1/8"	Third Angle Projection	Sheet: 2/7	Page Title: CUSTOMER CONNECTIONS
Part weight	Scale: NTS	Rev: 0	Drawing Number: G900-001

①

HOODS NOT PROVIDED ON INDOOR UNITS.
NOTE: SOME OUTDOOR CONFIGURATIONS
WILL NOT OVERHANG CABINET.

UNIT TYPE	MODEL SIZE	H1			L2 ①		OA BOX					
		NO VENTILATION	DUCT CONNECTION	OA BOX	INDOOR	OUTDOOR	HOOD(S)		L3	OUTDOOR OVERALL	W2	W1
							K	M				
WITHOUT ENERGY RECOVERY	18	49 1/8	52 1/2	77 1/2	131 1/8	131 1/8	17 3/8	N/A	28 3/4	46 1/8	77 1/8	81 3/8
	20	49 1/8	52 1/2	77 1/2	131 1/8	131 1/8	17 3/8	N/A	28 3/4	46 1/8	77 1/8	81 3/8
	24	59 1/8	62 1/2	87 1/2	131 1/8	131 1/8	17 3/8	N/A	28 3/4	46 1/8	77 1/8	81 3/8
	30	69 1/8	72 1/2	97 1/2	131 1/8	131 1/8	17 3/8	N/A	28 3/4	46 1/8	77 1/8	81 3/8
WITH ENERGY RECOVERY	18	N/A	N/A	89 1/2	164 1/2	177 1/8	23 3/8	23 3/8	67 1/8	113 7/8	77 1/8	81 3/4
	20	N/A	N/A	89 1/2	164 1/2	177 1/8	23 3/8	23 3/8	67 1/8	113 7/8	77 1/8	81 3/4
	24	N/A	N/A	99 1/2	164 1/2	177 1/8	23 3/8	23 3/8	67 1/8	113 7/8	77 1/8	81 3/4
	30	N/A	N/A	109 1/2	164 1/2	177 1/8	23 3/8	23 3/8	67 1/8	113 7/8	77 1/8	81 3/4

DUCT CONNECTION w/ DAMPER OPTION SHOWN

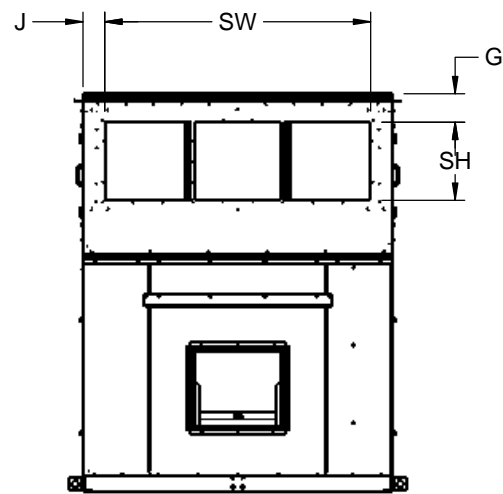
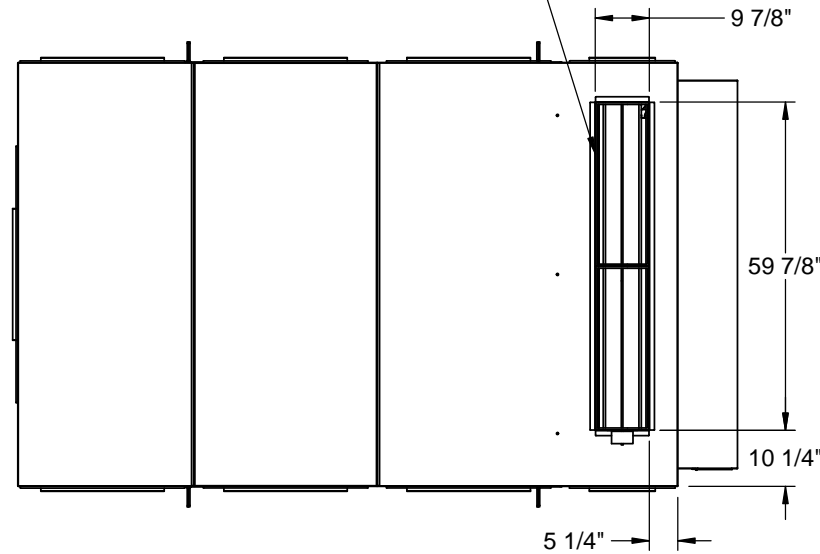

HOODS OMITTED FOR CLARITY

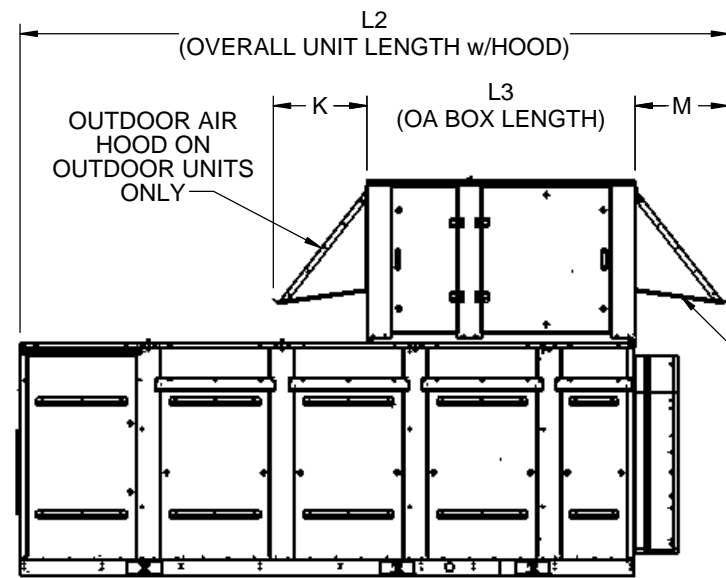

EXHAUST HOOD ONLY ON OUTDOOR ENERGY RECOVERY UNITS

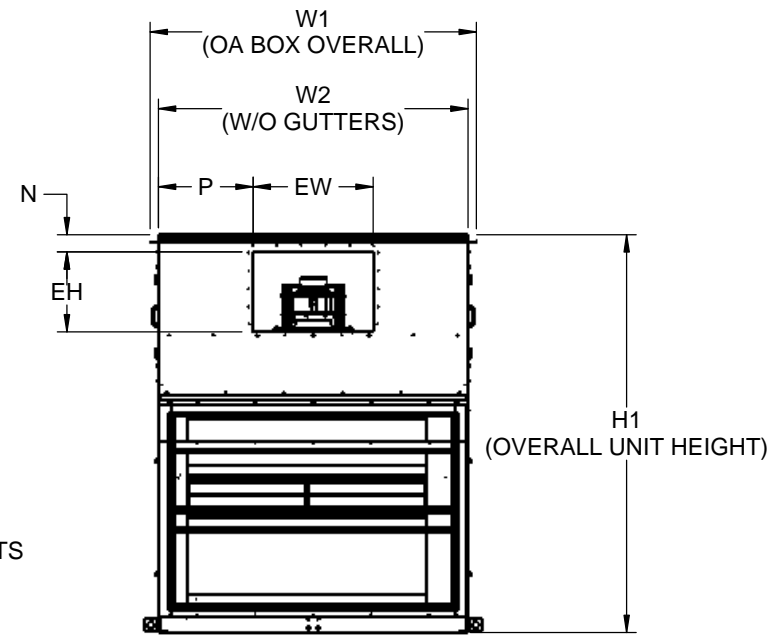

HOODS OMITTED FOR CLARITY

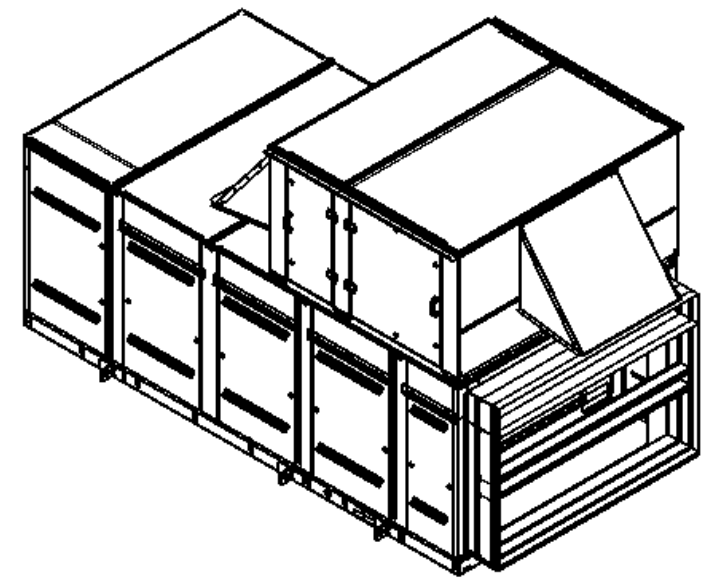

OA FILTERS	MODEL SIZE	PART NUMBER	QTY	NOM WIDTH	NOM HEIGHT	NOM DEPTH
DISPOSABLE	18	870-051	3	25	25	2
	20	870-051	3	25	25	2
	24	870-051	3	25	25	2
	30	870-051	3	25	25	2

UNIT TYPE	MODEL SIZE	OA INTAKE OPENING				EXHAUST DISCHARGE OPENING			
		SH	SW	G	J	EH	EW	N	P
WITHOUT ENERGY RECOVERY	18	20	60	2 1/4	8 5/8	N/A	N/A	N/A	N/A
	20	20	60	2 1/4	8 5/8	N/A	N/A	N/A	N/A
	24	20	60	2 1/4	8 5/8	N/A	N/A	N/A	N/A
	30	20	60	2 1/4	8 5/8	N/A	N/A	N/A	N/A
WITH ENERGY RECOVERY	18	19 1/2	66 1/2	7 1/8	5 3/8	20	30	4 1/4	23 5/8
	20	19 1/2	66 1/2	7 1/8	5 3/8	20	30	4 1/4	23 5/8
	24	19 1/2	66 1/2	7 1/8	5 3/8	20	30	4 1/4	23 5/8
	30	19 1/2	66 1/2	7 1/8	5 3/8	20	30	4 1/4	23 5/8

Desert Aire has a policy of continuous product and quality improvement. Specifications and dimensions are subject to change without notice. This drawing and information contained herein are the exclusive property of the Desert Aire Corporation. Any use detrimental to the interests of Desert Aire is prohibited.

All Dimensions in Inches
All Angles 90°
All outside corners 0.125" fillet
Unless Otherwise Specified



Third Angle Projection

Tolerance Unless Otherwise Specified
X.X ±.125
X.XX ±.060
X.XXX ±.030
Angles ±1°



N120 W18485 FREISTADT RD
GERMANTOWN, WI 53022
Tel: (262) 946-7400
Fax: (262) 946-7401

Drawn	ASV	Date Released	12/5/2014	Description	SA 18-30 TON STANDARD RETURN
Sheet	3/7			Page Title	OUTDOOR AIR/EXHAUST DETAILS
Scale	NTS		Rev.	0	Drawing Number
					G900-001

ALL DIMENSIONS ARE IN INCHES
FRACTIONAL TOLERANCE ± 1/8"

Part weight

18 TON					20 TON					24 TON					30 TON				
BLOWER	DH1	DW1	R1	Q1	BLOWER	DH1	DW1	R1	Q1	BLOWER	DH1	DW1	R1	Q1	BLOWER	DH1	DW1	R1	Q1
ATLI 15-11	16	14 7/8	14 1/4	31 1/4	ATLI 15-11	16	14 7/8	14 1/4	31 1/4	ATLI 18-13	18 7/8	17 1/2	16 3/8	30	ATLI 18-18	18 7/8	22 1/8	16 3/8	27 5/8
ATLI 18-13	18 7/8	17 1/2	16 3/8	30	ATLI 18-13	18 7/8	17 1/2	16 3/8	30	ATLI 18-18	18 7/8	22 1/8	16 3/8	27 5/8	ATLI 20-15	25 1/4	20 1/4	16 3/8	28 5/8
ATZAF 18-18	18 7/8	22 1/8	16 3/8	27 5/8	ATZAF 18-18	18 7/8	22 1/8	16 3/8	27 5/8	ATZAF 20-20	25 1/4	25 1/4	16 3/8	26 1/8	ATZAF 20-20	25 1/4	25 1/4	16 3/8	26 1/8
ATZAF 20-20	25 1/4	25 1/4	16 3/8	26 1/8	ATZAF 20-20	25 1/4	25 1/4	16 3/8	26 1/8	ATZAF 22-22	28 1/4	28 1/4	17 7/8	24 5/8	ATZAF 25-25	31 3/4	31 3/4	19 3/8	22 7/8
ATZAF 22-22	28 1/4	28 1/4	17 7/8	24 5/8	ATZAF 22-22	28 1/4	28 1/4	17 7/8	24 5/8	ATZAF 25-25	31 3/4	31 3/4	19 3/8	22 7/8					

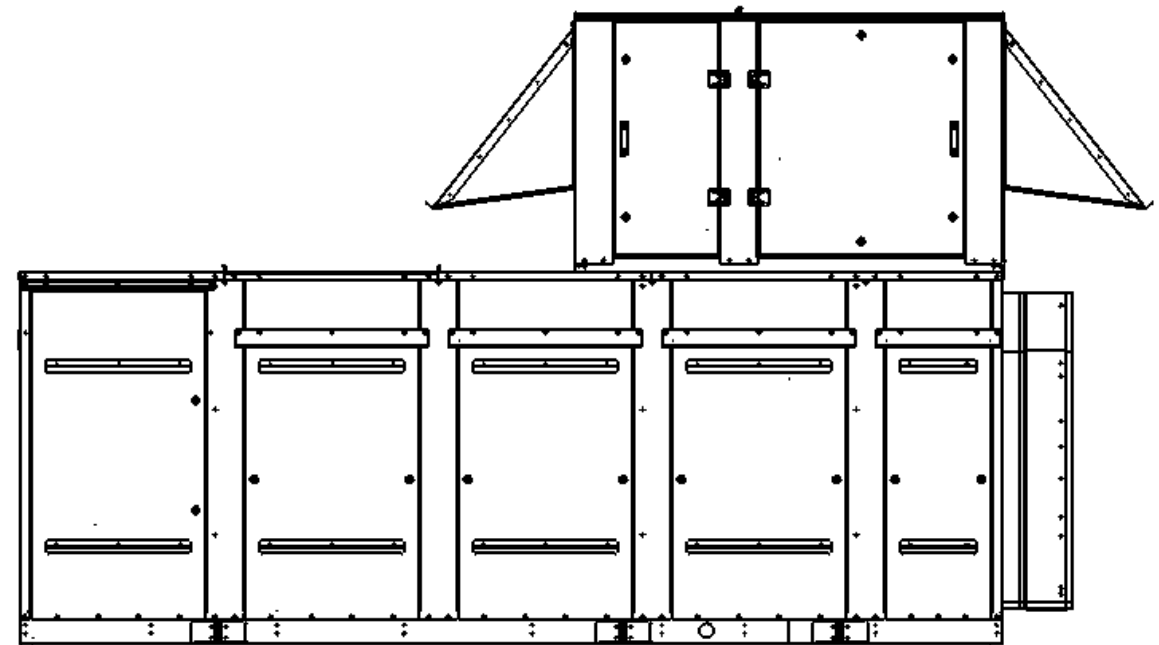
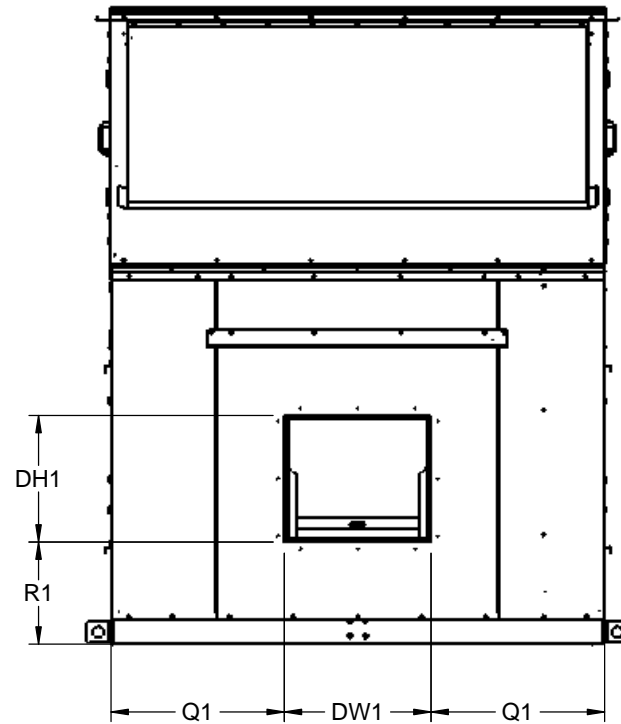
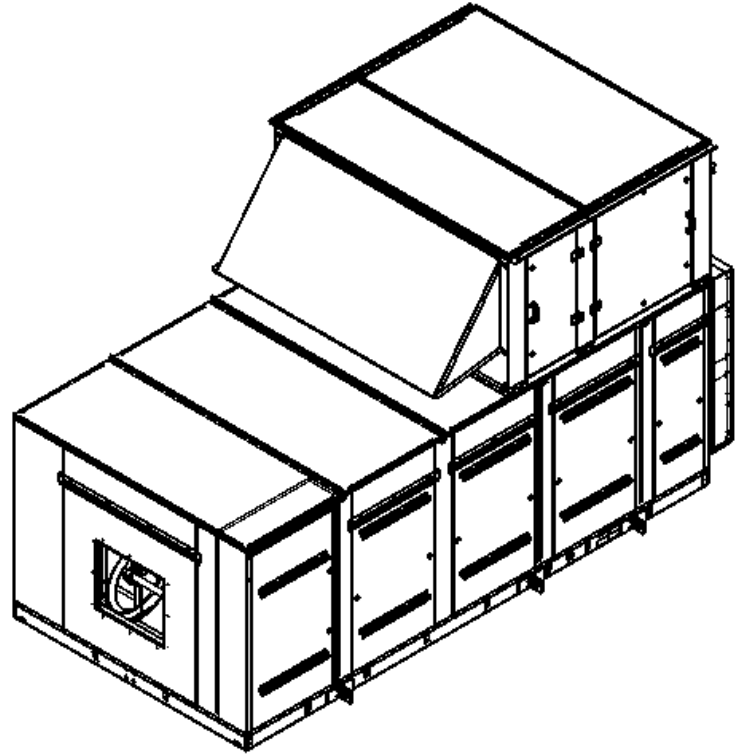

Desert Aire has a policy of continuous product and quality improvement. Specifications and dimensions are subject to change without notice. This drawing and information contained herein are the exclusive property of the Desert Aire Corporation. Any use detrimental to the interests of Desert Aire is prohibited.	All Dimensions in Inches All Angles 90° All outside corners 0.125" fillet Unless Otherwise Specified	Tolerance Unless Otherwise Specified X.X ±.125 X.XX ±.060 X.XXX ±.030 Angles ±1°	N120 W18485 FREISTADT RD GERMANTOWN, WI 53022 Tel: (262) 946-7400 Fax: (262) 946-7401
ALL DIMENSIONS ARE IN INCHES FRACTIONAL TOLERANCE ± 1/8"	Third Angle Projection	Sheet: 4/7 Scale: NTS Rev. 0	Page Title: END SUPPLY Drawing Number: G900-001

G900-001

18 TON						20 TON						24 TON						30 TON					
BLOWER	DH2	DW2	R2		Q2	BLOWER	DH2	DW2	R2		Q2	BLOWER	DH2	DW2	R2		Q2	BLOWER	DH2	DW2	R2		Q2
			OVER	AWAY					OVER	AWAY					OVER	AWAY					OVER	AWAY	
ATLI 15-11	16	14 7/8	2 1/8	9 3/4	31 1/4	ATLI 15-11	16	14 7/8	2 1/8	9 3/4	31 1/4	ATLI 18-13	18 7/8	17 1/2	2 1/8	11 7/8	30	ATLI 18-18	18 7/8	22 1/8	2 1/8	11 7/8	27 5/8
ATLI 18-13	18 7/8	17 1/2	2 1/8	11 7/8	30	ATLI 18-13	18 7/8	17 1/2	2 1/8	11 7/8	30	ATLI 18-18	18 7/8	22 1/8	2 1/8	11 7/8	27 5/8	ATLI 20-15	25 1/4	20 1/4	1 3/8	11 7/8	28 5/8
ATZAF 18-18	18 7/8	22 1/8	2 1/8	11 7/8	27 5/8	ATZAF 18-18	18 7/8	22 1/8	2 1/8	11 7/8	27 5/8	ATZAF 20-20	25 1/4	25 1/4	1 3/8	11 7/8	26 1/8	ATZAF 20-20	25 1/4	25 1/4	1 3/8	11 7/8	26 1/8
ATZAF 20-20	25 1/4	25 1/4	1 3/8	11 7/8	26 1/8	ATZAF 20-20	25 1/4	25 1/4	1 3/8	11 7/8	26 1/8	ATZAF 22-22	28 1/4	28 1/4	1 3/8	13 3/8	24 5/8	ATZAF 25-25	31 3/4	31 3/4	1 3/8	14 7/8	22 7/8
ATZAF 22-22	28 1/4	28 1/4	1 3/8	13 3/8	24 5/8	ATZAF 22-22	28 1/4	28 1/4	1 3/8	13 3/8	24 5/8	ATZAF 25-25	31 3/4	31 3/4	1 3/8	14 7/8	22 7/8						

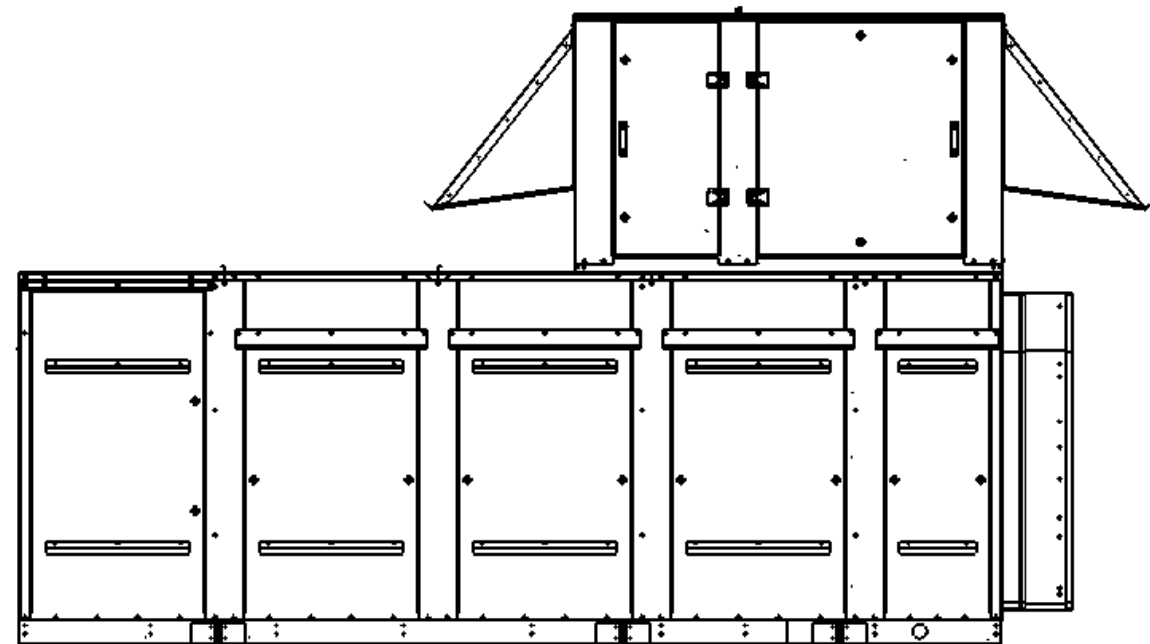
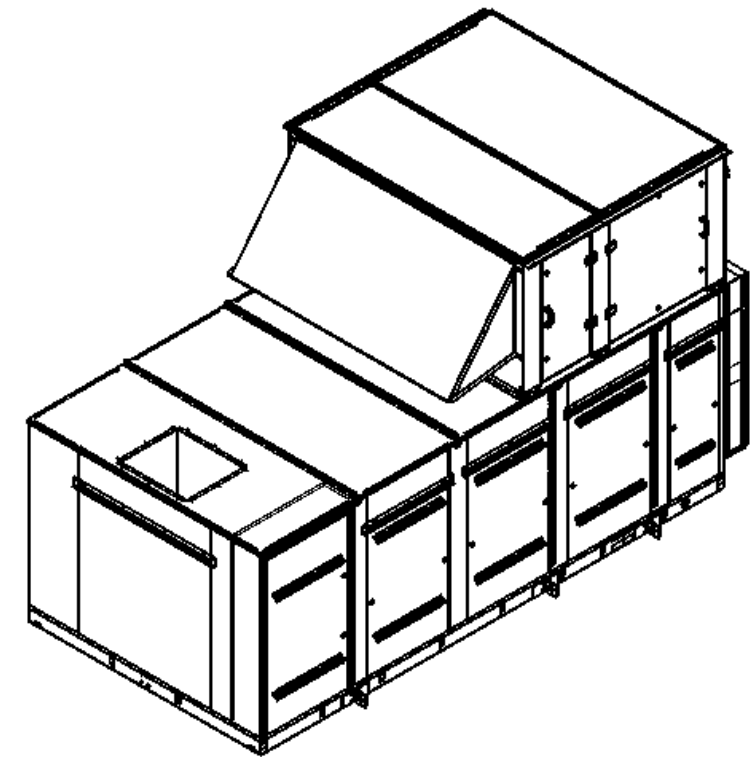
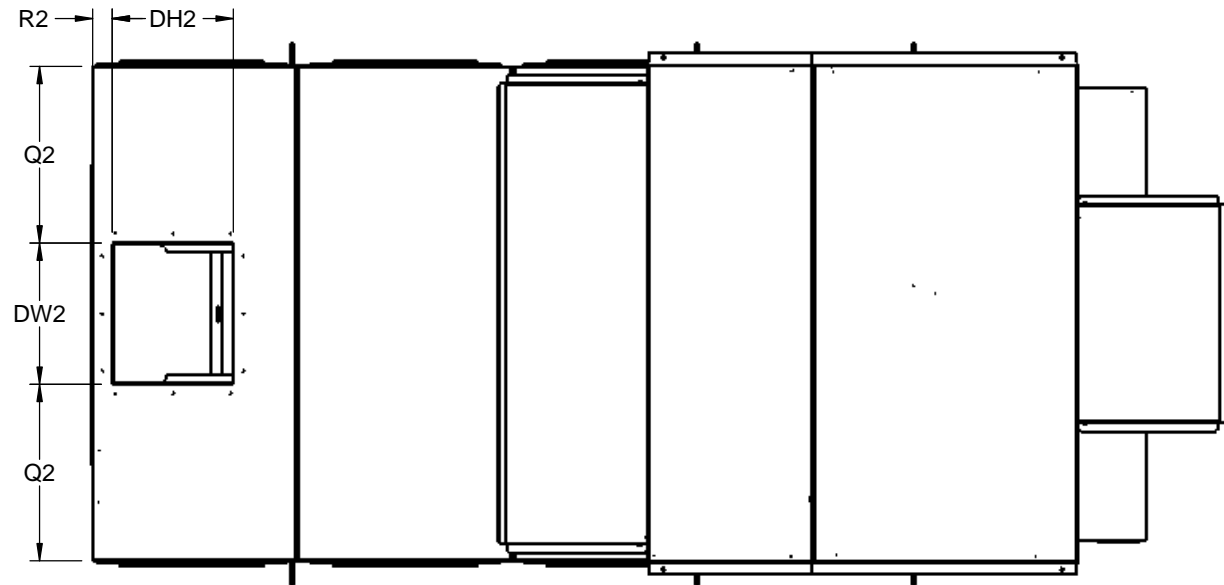

Desert Aire has a policy of continuous product and quality improvement. Specifications and dimensions are subject to change without notice. This drawing and information contained herein are the exclusive property of the Desert Aire Corporation. Any use detrimental to the interests of Desert Aire is prohibited.

ALL DIMENSIONS ARE IN INCHES
FRACTIONAL TOLERANCE ± 1/8"

All Dimensions in Inches
All Angles 90°
All outside corners 0.125" fillet
Unless Otherwise Specified

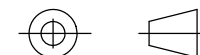

Third Angle Projection

Part weight

Tolerance Unless
Otherwise Specified
X.X ±.125
X.XX ±.060
X.XXX ±.030
Angles ±1°



N120 W18485 FREISTADT RD
GERMANTOWN, WI 53022
Tel: (262) 946-7400
Fax: (262) 946-7401

Drawn ASV	Date Released 12/5/2014	Description SA 18-30 TON STANDARD RETURN
Sheet 5/7	Page Title TOP SUPPLY	
Scale NTS	Rev. 0	Drawing Number G900-001

18 TON					20 TON					24 TON					30 TON				
BLOWER	DH3	DW3	R3	Q3	BLOWER	DH3	DW3	R3	Q3	BLOWER	DH3	DW3	R3	Q3	BLOWER	DH3	DW3	R3	Q3
ATLI 15-11	16	14 7/8	9 3/4	31 1/4	ATLI 15-11	16	14 7/8	9 3/4	31 1/4	ATLI 18-13	18 7/8	17 1/2	11 7/8	30	ATLI 18-18	18 7/8	22 1/8	11 7/8	27 5/8
ATLI 18-13	18 7/8	17 1/2	11 7/8	30	ATLI 18-13	18 7/8	17 1/2	11 7/8	30	ATLI 18-18	18 7/8	22 1/8	11 7/8	27 5/8	ATLI 20-15	25 1/4	20 1/4	11 7/8	28 5/8
ATZAF 18-18	18 7/8	22 1/8	11 7/8	27 5/8	ATZAF 18-18	18 7/8	22 1/8	11 7/8	27 5/8	ATZAF 20-20	25 1/4	25 1/4	11 7/8	26 1/8	ATZAF 20-20	25 1/4	25 1/4	11 7/8	26 1/8
ATZAF 20-20	25 1/4	25 1/4	11 7/8	26 1/8	ATZAF 20-20	25 1/4	25 1/4	11 7/8	26 1/8	ATZAF 22-22	28 1/4	28 1/4	13 3/8	24 5/8	ATZAF 25-25	31 3/4	31 3/4	14 7/8	22 7/8
ATZAF 22-22	28 1/4	28 1/4	13 3/8	24 5/8	ATZAF 22-22	28 1/4	28 1/4	13 3/8	24 5/8	ATZAF 25-25	31 3/4	31 3/4	14 7/8	22 7/8					

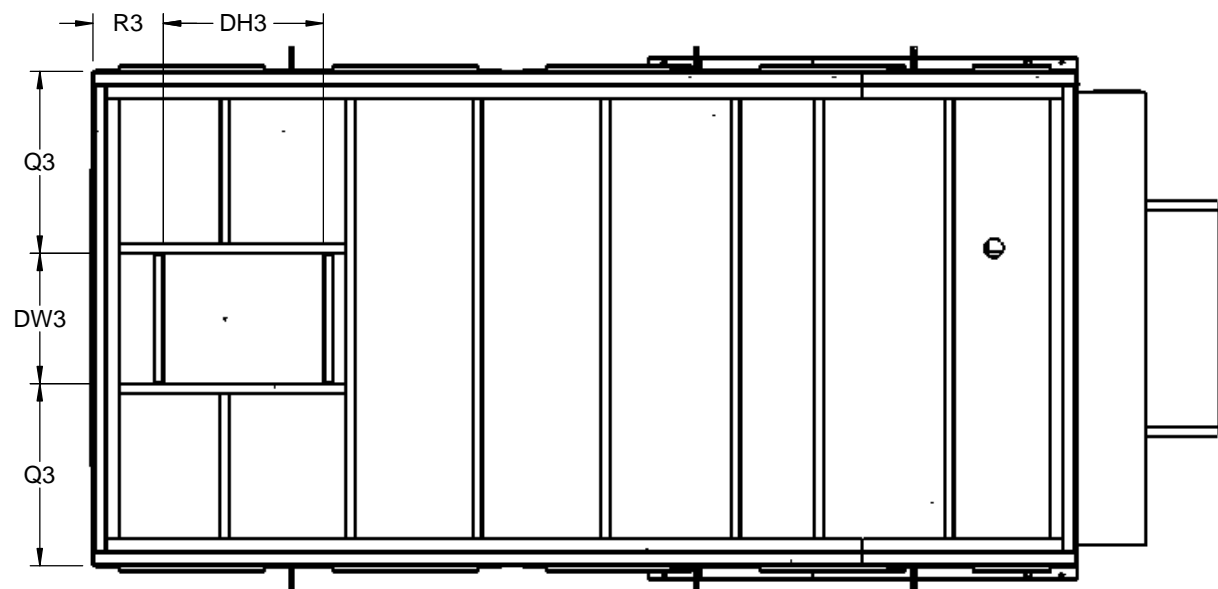
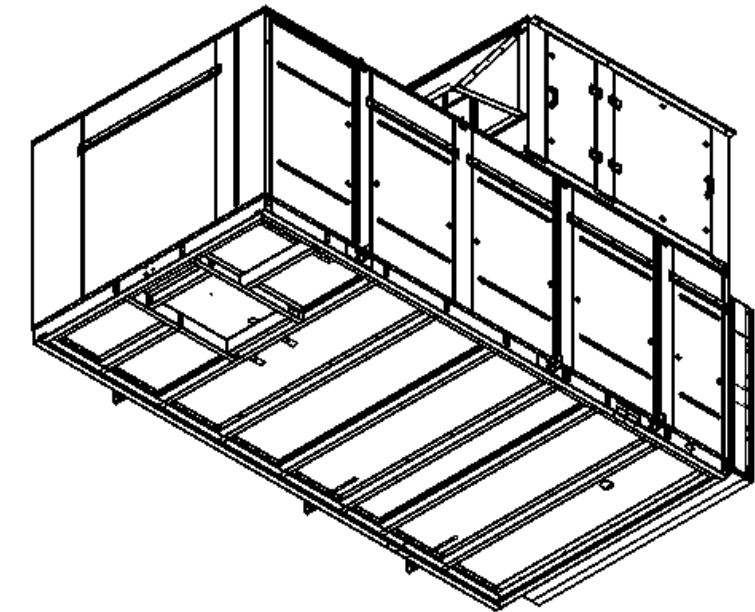
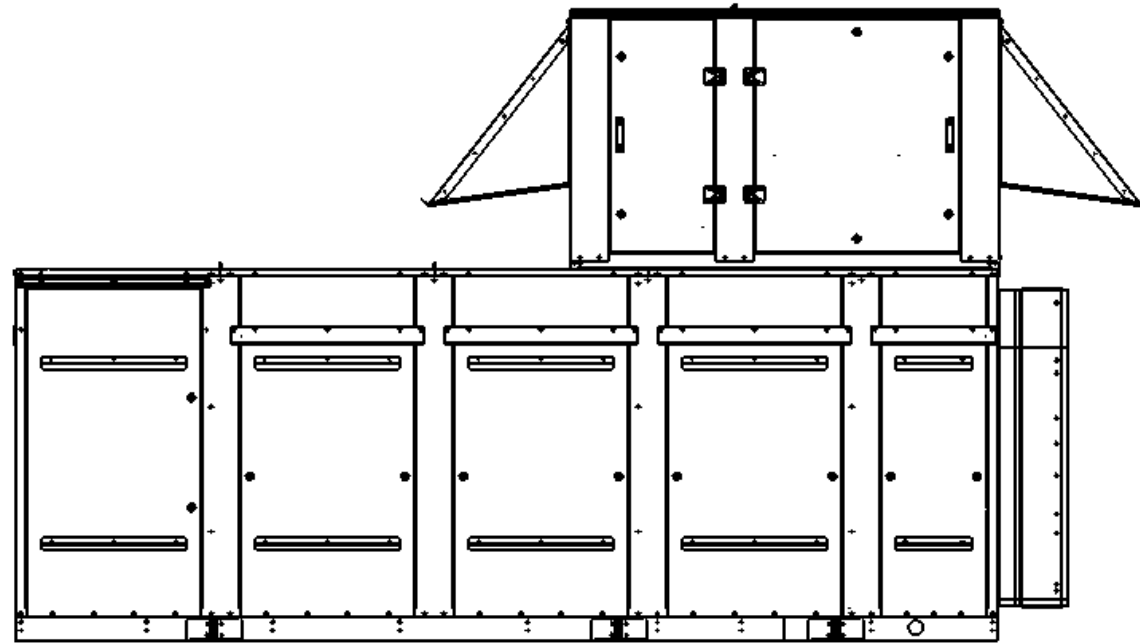

Desert Aire has a policy of continuous product and quality improvement. Specifications and dimensions are subject to change without notice. This drawing and information contained herein are the exclusive property of the Desert Aire Corporation. Any use detrimental to the interests of Desert Aire is prohibited.	All Dimensions in Inches All Angles 90° All outside corners 0.125" fillet Unless Otherwise Specified	Tolerance Unless Otherwise Specified X.X ±.125 X.XX ±.060 X.XXX ±.030 Angles ±1°	N120 W18485 FREISTADT RD GERMANTOWN, WI 53022 Tel: (262) 946-7400 Fax: (262) 946-7401
ALL DIMENSIONS ARE IN INCHES FRACTIONAL TOLERANCE ± 1/8"	Third Angle Projection	Sheet: 6/7 Scale: NTS	Page Title: DOWN SUPPLY Rev. 0 Drawing Number: G900-001

G900-001

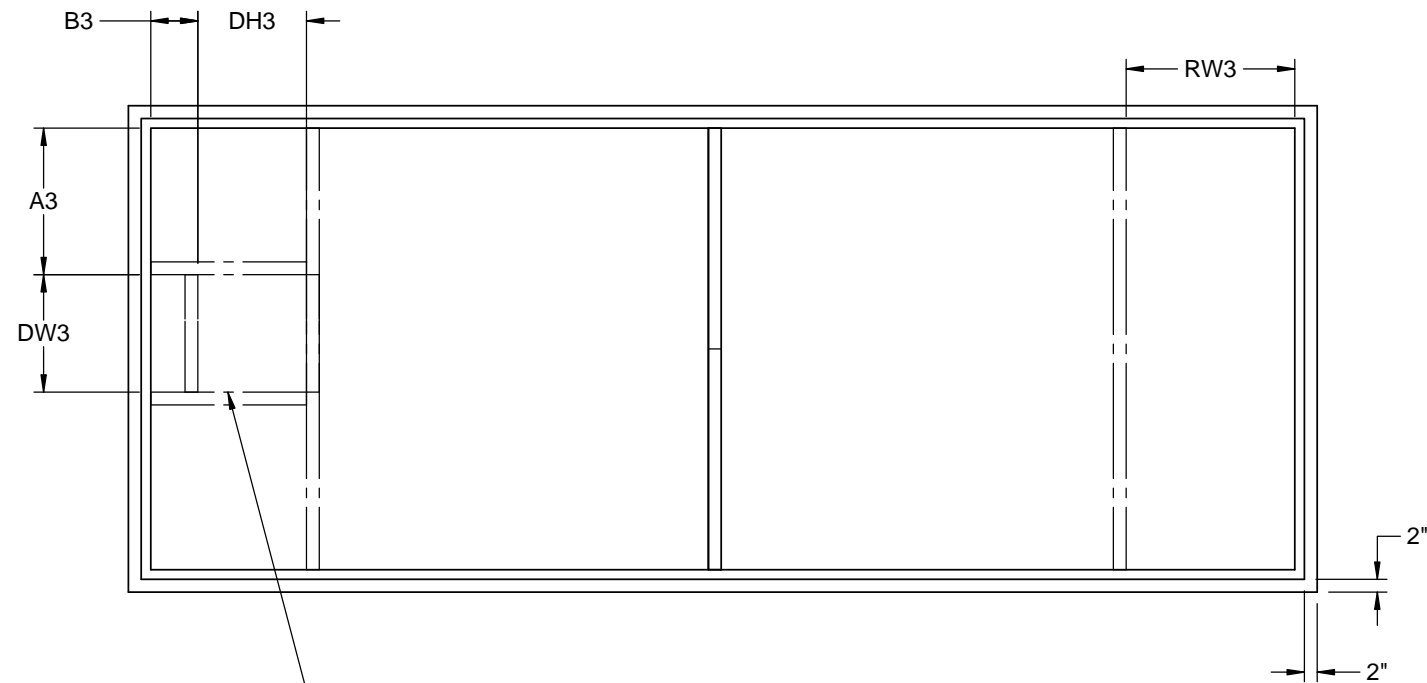

UNIT TYPE	CURB DETAILS			DOWN SUPPLY AND / OR DOWN RETURN				
	CURB PN	LENGTH	WIDTH	RW3	DW3	A3	DH3	B3
WITHOUT ENERGY RECOVERY	CB-SWAA-XX	115	72	57 1/2	14 7/8	27 1/8	16	5 3/4
	CB-SWAB-XX	115	72	57 1/2	17 1/2	25 3/4	18 7/8	7 7/8
	CB-SWAC-XX	115	72	57 1/2	22 1/8	23 1/2	18 7/8	7 7/8
	CB-SWAD-XX	115	72	57 1/2	20 1/4	24 3/8	25 1/4	7 7/8
	CB-SWAG-XX	115	72	57 1/2	22 1/8	23 1/2	18 7/8	7 7/8
	CB-SWAH-XX	115	72	57 1/2	25 1/4	21 7/8	25 1/4	7 7/8
	CB-SWAJ-XX	115	72	57 1/2	28 1/4	20 3/8	28 1/4	9 3/8
	CB-SWAK-XX	115	72	57 1/2	31 3/4	18 5/8	31 3/4	10 7/8
	CB-SWAZ-XX	115	72	57 1/2	NO SUPPLY/RETURN DUCT CONNECITON			
WITH ENERGY RECOVERY	CB-SRAA-XX	148 3/8	72	74 1/4	14 7/8	27 1/8	16	5 3/4
	CB-SRAB-XX	148 3/8	72	74 1/4	17 1/2	25 3/4	18 7/8	7 7/8
	CB-SRAC-XX	148 3/8	72	74 1/4	22 1/8	23 1/2	18 7/8	7 7/8
	CB-SRAD-XX	148 3/8	72	74 1/4	20 1/4	24 3/8	25 1/4	7 7/8
	CB-SRAG-XX	148 3/8	72	74 1/4	22 1/8	23 1/2	18 7/8	7 7/8
	CB-SRAH-XX	148 3/8	72	74 1/4	25 1/4	21 7/8	25 1/4	7 7/8
	CB-SRAJ-XX	148 3/8	72	74 1/4	28 1/4	20 3/8	28 1/4	9 3/8
	CB-SRAK-XX	148 3/8	72	74 1/4	31 3/4	18 5/8	31 3/4	10 7/8
	CB-SRAZ-XX	148 3/8	72	74 1/4	NO SUPPLY/RETURN DUCT CONNECITON			

CURB HEIGHT IN INCHES DESIGNATED BY XX IN THE CURB PART NUMBER

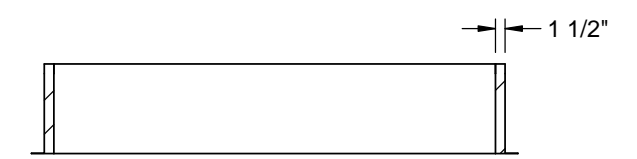
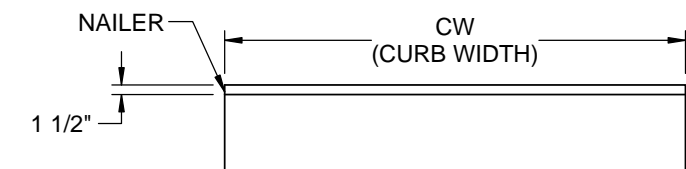
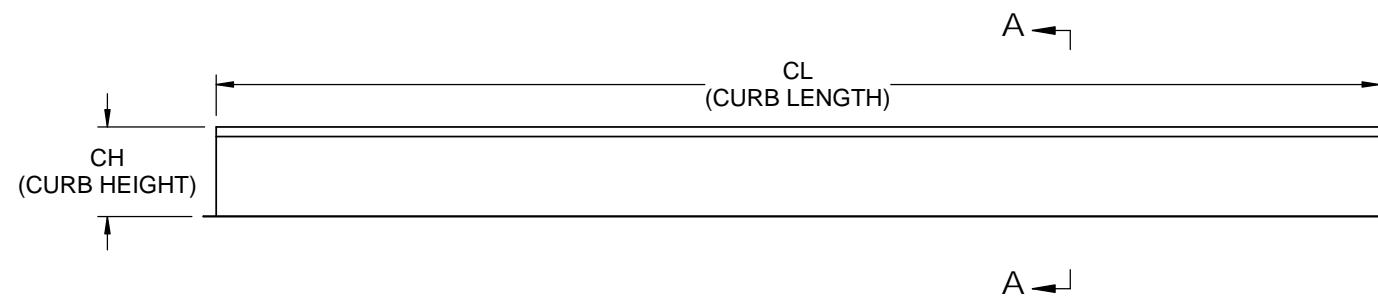

DUCT CONNECTIONS FOR DOWN SUPPLY AND/OR DOWN RETURN

NOTES:
REFER TO SHEET 1 FOR GENERAL NOTES

CURBS 115" IN LENGTH AND LESS ARE SHIPPED AS COMPLETE CURBS, GREATER THAN 115" ARE SHIPPED KNOCKED DOWN.

NUMBER AND LOCATION OF CROSS SUPPORT(S) IS DEPENDANT UPON THE GAUGE OF MATERIAL USED TO CONSTRUCT THE CURB, DUCT SUPPORT CONFIGURATION, LENGTH OF CURB, AND WIDTH OF CURB. INSTALLATION INSTRUCTIONS INCLUDED WITH CURB SHIPMENT INDICATE THE REQUIRED POSITION FOR FIELD ASSEMBLED CURBS.

Desert Aire has a policy of continuous product and quality improvement. Specifications and dimensions are subject to change without notice. This drawing and information contained herein are the exclusive property of the Desert Aire Corporation. Any use detrimental to the interests of Desert Aire is prohibited.	All Dimensions in Inches All Angles 90° All outside corners 0.125" fillet Unless Otherwise Specified	Tolerance Unless Otherwise Specified X.X ±.125 X.XX ±.060 X.XXX ±.030 Angles ±1°	N120 W18485 FREISTADT RD GERMANTOWN, WI 53022 Tel: (262) 946-7400 Fax: (262) 946-7401
ALL DIMENSIONS ARE IN INCHES TOLERANCE ± 1/8"	Third Angle Projection	Sheet 7/7	Page Title CURB DETAILS
Part weight	Scale NTS	Rev. 0	Drawing Number G900-001

G900-001-G

HEATER SIZE	WITH RECOVERY RL	WITHOUT RECOVERY RL	WITH RECOVERY HL	WITHOUT RECOVERY HL	HL-C	HL-1	HH-C	HW	NPT DIA.	HEATER LBS
HF400	153 3/8	120	310 7/8	277 1/2	37 1/2	60	8	99 3/4	1	732
HF550	153 3/8	120	310 7/8	277 1/2	38 1/4	60	7	99 3/4	1 1/4	881
HF750	153 3/8	120	324 7/8	291 1/2	43 3/8	74	7 1/8	98 1/4	1 1/4	1138
HF1000	153 3/8	120	330 7/8	297 1/2	45	80	7 3/8	110 3/4	1 1/2	1244
HF1250	153 3/8	120	336 7/8	303 1/2	45	86	7 3/8	110 3/4	1 1/2	1369

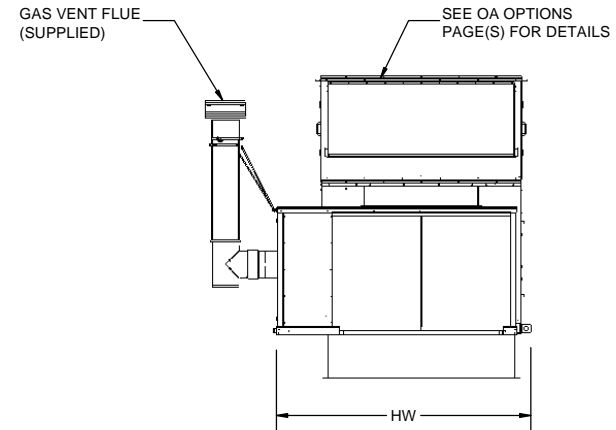
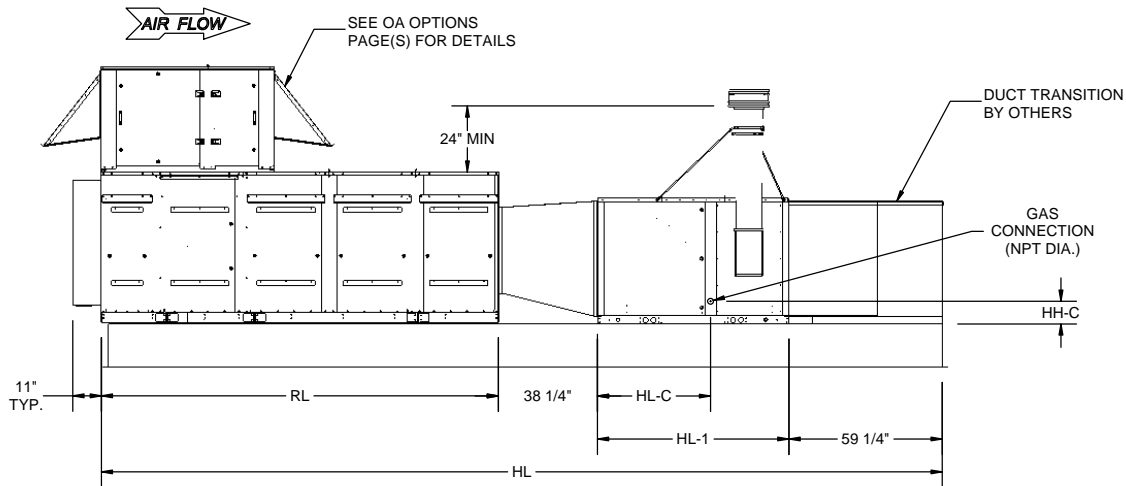
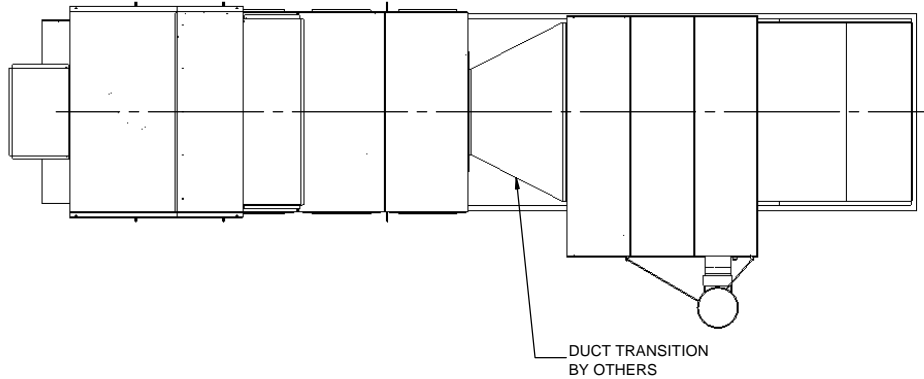

NOTE:
CONSULT MAIN GENERAL ARRANGEMENT DRAWING FOR UNIT SPECIFIC DIMENSIONS.
CONSULT FACTORY FOR INDOOR APPLICATIONS.

Desert Aire has a policy of continuous product and quality improvement. Specifications and dimensions are subject to change without notice. This drawing and information contained herein are the exclusive property of the Desert Aire Corporation. Any use detrimental to the interests of Desert Aire is prohibited.	All Dimensions in Inches All Angles 90° All outside corners 0.125" fillet Unless Otherwise Specified	Tolerance Unless Otherwise Specified X.X ±.125 X.XX ±.060 X.XXX ±.030 Angles ±1°	N120 W18485 FREISTADT RD GERMANTOWN, WI 53022 Tel: (262) 946-7400 Fax: (262) 946-7401
ALL DIMENSIONS ARE IN INCHES TOLERANCE ± 1/8"	Third Angle Projection	Sheet: 1/6	Page Title: OVERVIEW
Part weight:	Scale: NTS	Rev: 2	Drawing Number: G900-001-G

G900-001-G

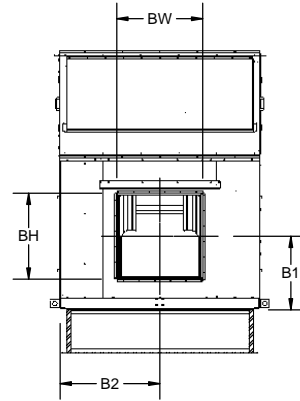
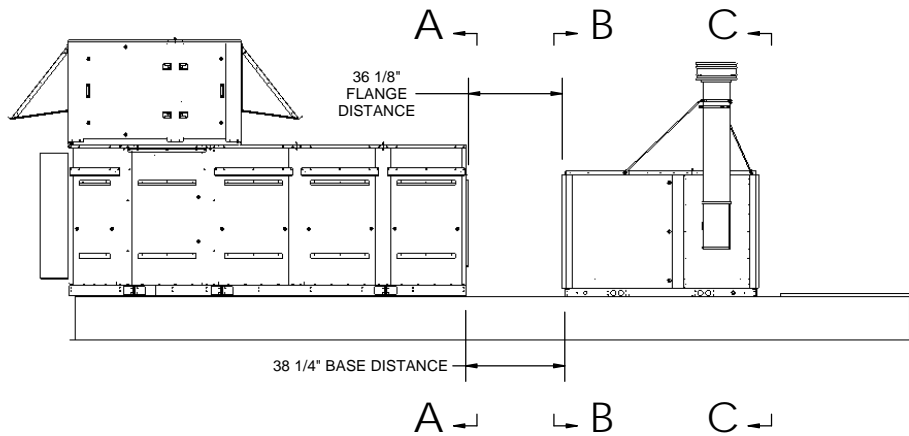
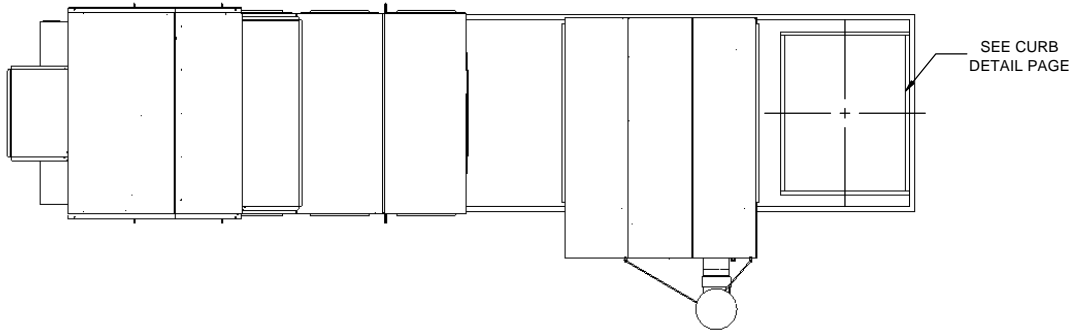

SECTION A-A
END OF UNIT

BLOWER NUMBER, BLOWER OPENING HEIGHT, BLOWER OPENING WIDTH												
18 TON				20 TON								
BLOWER	BH	BW	B2	BLOWER	BH	BW	B2					
ATLI 15-11	17 1/2	16 5/16	38 1/2	ATLI 15-11	17 1/2	16 5/16	38 1/2					
ATLI 18-13	20 7/16	19	38 1/2	ATLI 18-13	20 7/16	19	38 1/2					
ATZAF 18-18	20 7/16	23 7/16	38 1/2	ATZAF 18-18	20 7/16	23 7/16	38 1/2					
ATZAF 20-20	26 3/4	26 3/4	38 1/2	ATZAF 20-20	26 3/4	26 3/4	38 1/2					
ATZAF 22-22	-	-	-	ATZAF 22-22	-	-	-					
24 TON				30 TON								
BLOWER	BH	BW	B2	BLOWER	BH	BW	B2					
ATLI 18-13	20 7/16	19	38 1/2	ATLI 18-18	20 7/16	23 9/16	38 1/2					
ATLI 18-18	20 7/16	23 9/16	38 1/2	ATLI 20-15	26 3/4	21 3/4	38 1/2					
ATZAF 20-20	26 3/4	26 3/4	38 1/2	ATZAF 20-20	26 3/4	26 3/4	38 1/2					
ATZAF 22-22	29 3/4	29 3/4	38 1/2	ATZAF 25-25	33 3/16	33 3/16	38 1/2					
ATZAF 25-25	33 3/16	33 3/16	38 1/2									

NOTE:
HEATER INLET AND OUTLET ARE THE SAME DIMENSIONS

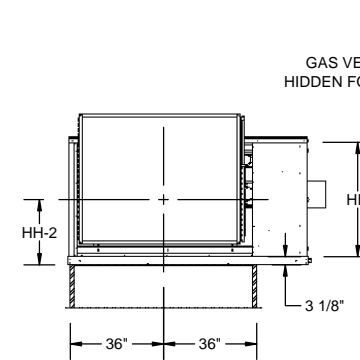

SECTION B-B
INTAKE OF HEATER

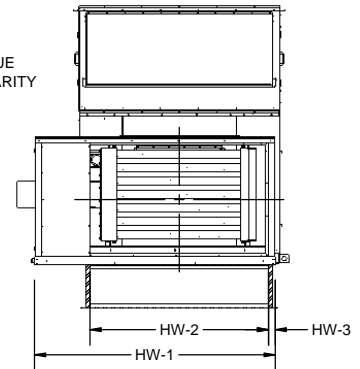

SECTION C-C
OUTLET OF HEATER

HEATER SIZE	B1 ATLI 15-11	B1 ATLI 18-13	B1 ATLI 18-18	B1 ATLI 20-15	B1 ATZAF 18-18	B1 ATZAF 20-20	B1 ATZAF 22-22	B1 ATZAF 25-25	HW-1	HW-2	HW-3	HH	HH-2
HF400	24 7/8	25 3/8	25 3/8	26 3/8	25 3/8	26 1/2	26 7/8	27 1/2	90 1/2	61	2 5/8	38	22 1/8
HF550	27 7/8	27 7/8	28 1/2	29 3/8	27 7/8	28 1/2	29 7/8	28 1/2	90 1/2	61	2 5/8	44	25 1/8
HF750	27 7/8	27 7/8	28 1/2	29 3/8	27 7/8	28 1/2	29 7/8	28 1/2	93	69	2 5/8	44 1/4	25 1/4
HF1000	-	-	31 1/2	32 3/8	-	26 1/2	30 7/8	33 1/2	108 1/2	75	2 5/8	50	28 1/8
HF1250	-	-	31 1/2	32 3/8	-	26 1/2	30 7/8	33 1/2	108 1/2	75	2 5/8	50	28 1/8

Desert Aire has a policy of continuous product and quality improvement. Specifications and dimensions are subject to change without notice. This drawing and information contained herein are the exclusive property of the Desert Aire Corporation. Any use detrimental to the interests of Desert Aire is prohibited.	All Dimensions in Inches All Angles 90° All outside corners 0.125" fillet Unless Otherwise Specified	Tolerance Unless Otherwise Specified X.X ±.125 X.XX ±.060 X.XXX ±.030 Angles ±1°	N120 W18485 FREISTADT RD GERMANTOWN, WI 53022 Tel: (262) 946-7400 Fax: (262) 946-7401	
	Third Angle Projection	Drawn: MHB Date Released:		Description: GA SA 18-30T GAS HTR
	ALL DIMENSIONS ARE IN INCHES TOLERANCE ± 1/8"	Part weight	Sheet: 2/6 Scale: NTS Rev: 2	Page Title: BLOWER & HEATER CONNECTIONS Drawing Number: G900-001-G

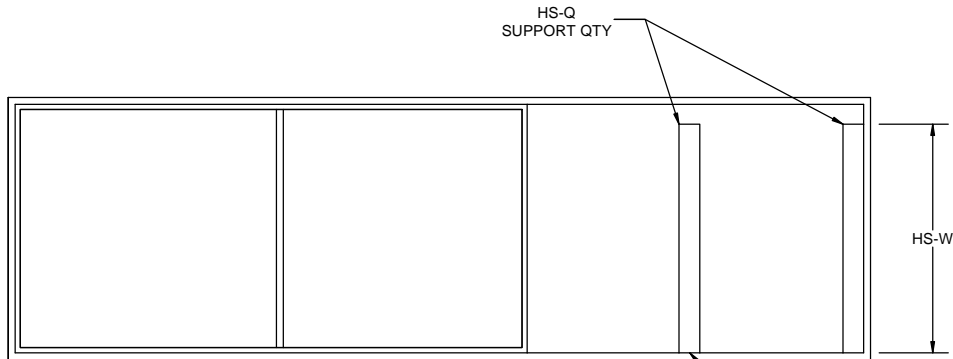

SHOWN: RIGHT HAND OPTION (HS-Q SUPORTS ARE FLUSH W/RIGHT CURB EDGE)
 NOT SHOWN: LEFT HAND OPTION (HS-Q SUPORTS ARE FLUSH W/ LEFT CURB EDGE)

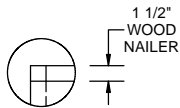
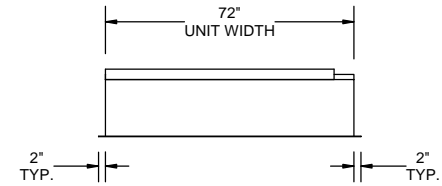
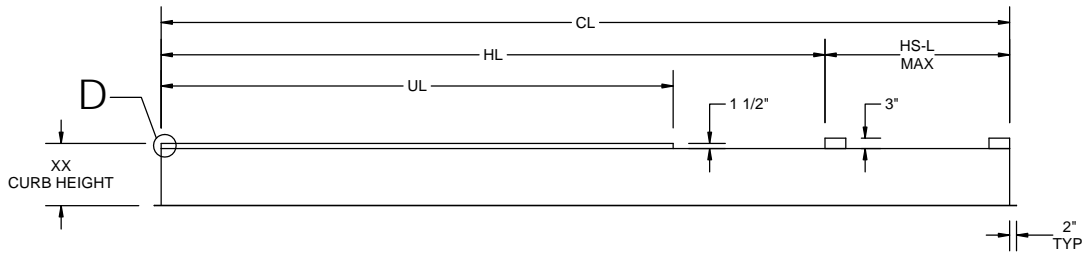

DETAIL D
 SCALE 1 : 12

HEATER CONNECTION SIZES - END DISCHARGE							
CURB PN	HEATER SIZE	HS-W	HS-L	UL	HL	CL	CURB LBS
CB-SWAX-XX#0400	HF400	66 1/4	53 1/2	115	159	212 1/2	631
CB-SWAX-XX#0550	HF550	66 1/4	53 1/2	115	159	212 1/2	631
CB-SWAX-XX#0750	HF750	70 1/4	67 1/2	115	159	226 1/2	668
CB-SWAX-XX#1000	HF1000	72	73 1/2	115	159	232 1/2	684
CB-SWAX-XX#1250	HF1250	72	79 1/2	115	159	238 1/2	699
WITH ENERGY RECOVERY							
CB-SRAX-XX#0400	HF400	66 1/4	53 1/2	148 3/8	192 3/8	245 7/8	635
CB-SRAX-XX#0550	HF550	66 1/4	53 1/2	148 3/8	192 3/8	245 7/8	635
CB-SRAX-XX#0750	HF750	70 1/4	67 1/2	148 3/8	192 3/8	259 7/8	716
CB-SRAX-XX#1000	HF1000	72	73 1/2	148 3/8	192 3/8	265 7/8	732
CB-SRAX-XX#1250	HF1250	72	79 1/2	148 3/8	192 3/8	271 7/8	747

XX = CURB HEIGHT IN INCHES
 # = HEATER CONTROLS LOCATION L (LEFT) OR R (RIGHT)

1. GALVANIZED STEEL CONSTRUCTION.
2. FULLY WELDED WATERTIGHT ONE PIECE CURB.
3. PRIME PAINTED AFTER FABRICATION.
4. THE CURB HAS 1-1/2" THICK 3LB/FT³ FIBERGLASS PERIMETER INSULATION.
5. INTERNAL ANGLE REINFORCEMENT AS NEEDED.
6. CURB TO BE CURBS PLUS INC. CPC-3 STYLE.

Desert Aire has a policy of continuous product and quality improvement. Specifications and dimensions are subject to change without notice. This drawing and information contained herein are the exclusive property of the Desert Aire Corporation. Any use detrimental to the interests of Desert Aire is prohibited.	All Dimensions in Inches All Angles 90° All outside corners 0.125" fillet Unless Otherwise Specified	Tolerance Unless Otherwise Specified X.X ±.125 X.XX ±.060 X.XXX ±.030 Angles ±1°	N120 W18485 FREISTADT RD GERMANTOWN, WI 53022 Tel: (262) 946-7400 Fax: (262) 946-7401
	ALL DIMENSIONS ARE IN INCHES TOLERANCE ± 1/8"	Third Angle Projection	

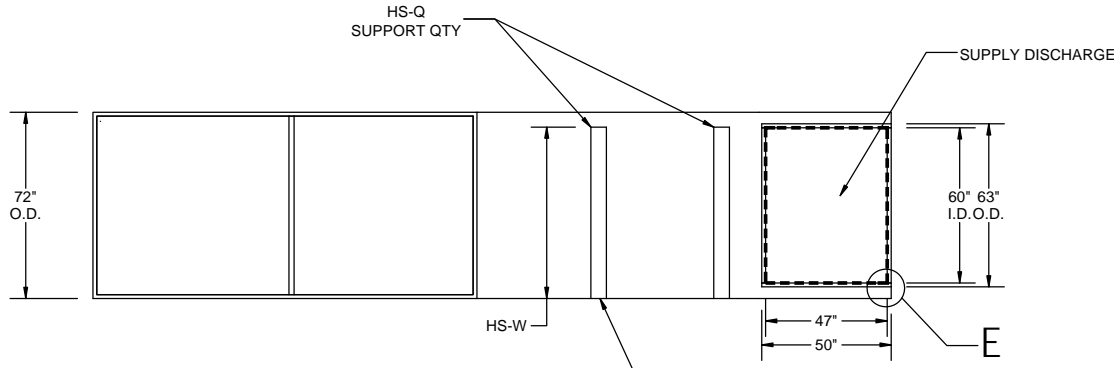

SHOWN: RIGHT HAND OPTION (HS-Q SUPORTS ARE FLUSH W/RIGHT CURB EDGE)
 NOT SHOWN: LEFT HAND OPTION (HS-Q SUPORTS ARE FLUSH W/ LEFT CURB EDGE)

HEATER CONNECTION SIZES - DOWN DISCHARGE							
CURB PN	HEATER SIZE	HS-W	HS-L	UL	HL	CL	CURB LBS
CB-SWAY-XX#0400	HF400	66 1/4	53 1/2	115	159	275	828
CB-SWAY-XX#0550	HF550	66 1/4	53 1/2	115	159	275	828
CB-SWAY-XX#0750	HF750	70 1/4	67 1/2	115	159	289	865
CB-SWAY-XX#1000	HF1000	72	73 1/2	115	159	295	880
CB-SWAY-XX#1250	HF1250	72	79 1/2	115	159	301	896
WITH ENERGY RECOVERY							
CB-SRAY-XX#0400	HF400	66 1/4	53 1/2	148 3/8	192 3/8	308 3/8	877
CB-SRAY-XX#0550	HF550	66 1/4	53 1/2	148 3/8	192 3/8	308 3/8	877
CB-SRAY-XX#0750	HF750	70 1/4	67 1/2	148 3/8	192 3/8	322 3/8	898
CB-SRAY-XX#1000	HF1000	72	73 1/2	148 3/8	192 3/8	328 3/8	930
CB-SRAY-XX#1250	HF1250	72	79 1/2	148 3/8	192 3/8	334 3/8	945

XX = CURB HEIGHT IN INCHES
 # = HEATER CONTROLS LOCATION L (LEFT) OR R (RIGHT)

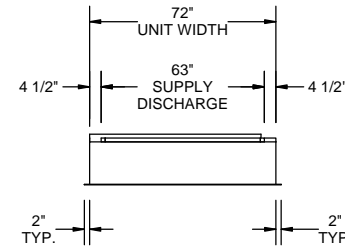
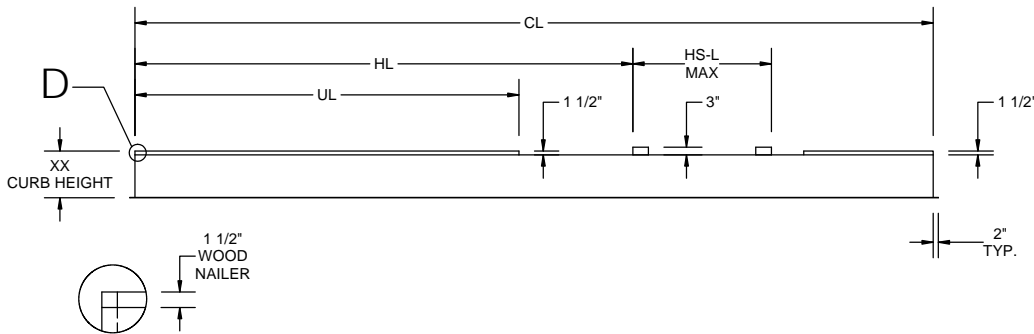
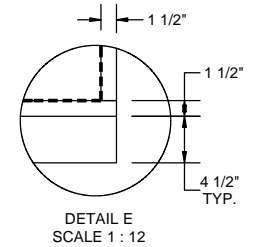

1. GALVANIZED STEEL CONSTRUCTION.
2. FULLY WELDED WATERTIGHT ONE PIECE CURB.
3. PRIME PAINTED AFTER FABRICATION.
4. THE CURB HAS 1-1/2" THICK 3LB/FT³ FIBERGLASS PERIMETER INSULATION.
5. INTERNAL ANGLE REINFORCEMENT AS NEEDED.
6. CURB TO BE CURBS PLUS INC. CPC-3 STYLE.

Desert Aire has a policy of continuous product and quality improvement. Specifications and dimensions are subject to change without notice. This drawing and information contained herein are the exclusive property of the Desert Aire Corporation. Any use detrimental to the interests of Desert Aire is prohibited.	All Dimensions in Inches All Angles 90° All outside corners 0.125" fillet Unless Otherwise Specified	Tolerance Unless Otherwise Specified X.X ±.125 X.XX ±.060 X.XXX ±.030 Angles ±1°	N120 W18485 FREISTADT RD GERMANTOWN, WI 53022 Tel: (262) 946-7400 Fax: (262) 946-7401
ALL DIMENSIONS ARE IN INCHES TOLERANCE ± 1/8"	Third Angle Projection	Sheet: 4/6	Page Title: DOWN DISCHARGE
Part weight:	Scale: NTS	Rev: 2	Drawing Number: G900-001-G

G900-001-G

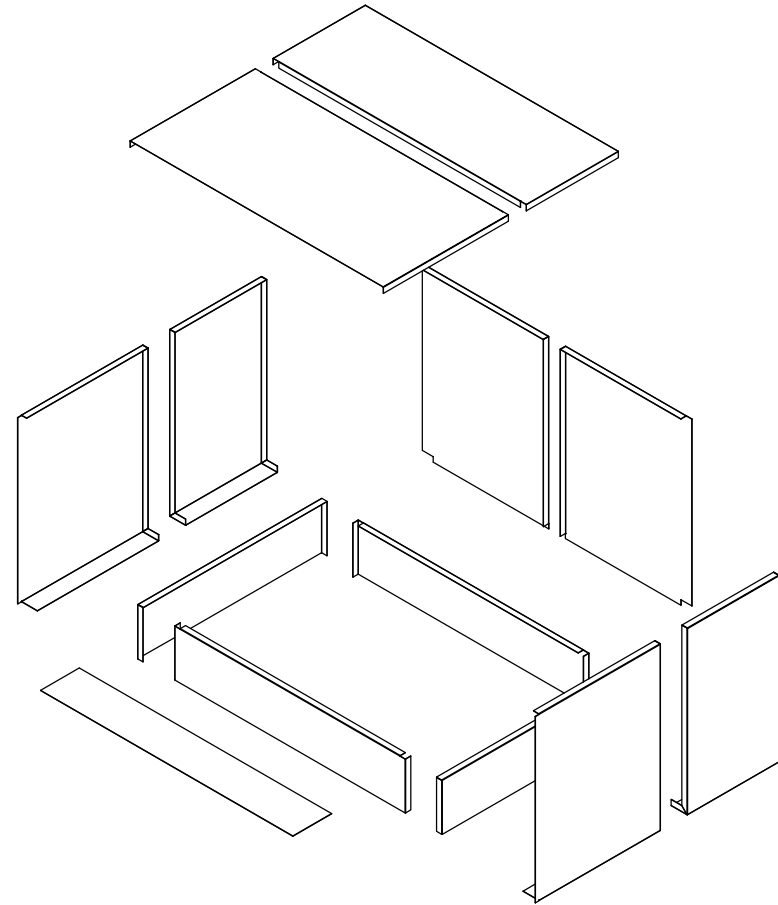
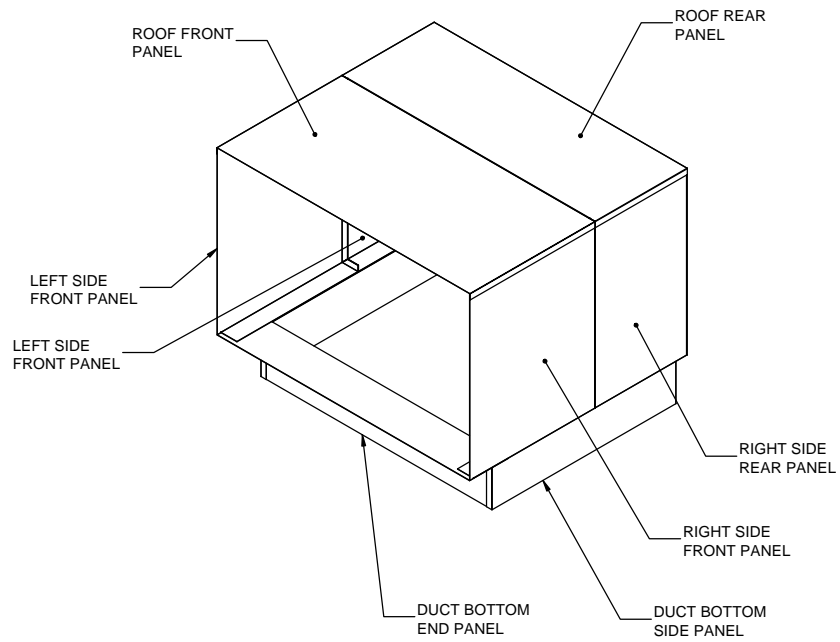

DUCT TRANSITION BY OTHERS.
 DUCT ASSEMBLY IS FOR REFERENCE ONLY!
 ALTERNATE CONSTRUCTION IS ACCEPTABLE.

Desert Aire has a policy of continuous product and quality improvement. Specifications and dimensions are subject to change without notice. This drawing and information contained herein are the exclusive property of the Desert Aire Corporation. Any use detrimental to the interests of Desert Aire is prohibited.	All Dimensions in Inches All Angles 90° All outside corners 0.125" fillet Unless Otherwise Specified	Tolerance Unless Otherwise Specified X.X ±.125 X.XX ±.060 X.XXX ±.030 Angles ±1°	N120 W18485 FREISTADT RD GERMANTOWN, WI 53022 Tel: (262) 946-7400 Fax: (262) 946-7401
ALL DIMENSIONS ARE IN INCHES TOLERANCE ± 1/8"	Third Angle Projection 	Sheet: 5/6	Page Title: DOWN DISCHARGE DUCT
		Part weight:	Scale: NTS Rev: 2 Drawing Number: G900-001-G

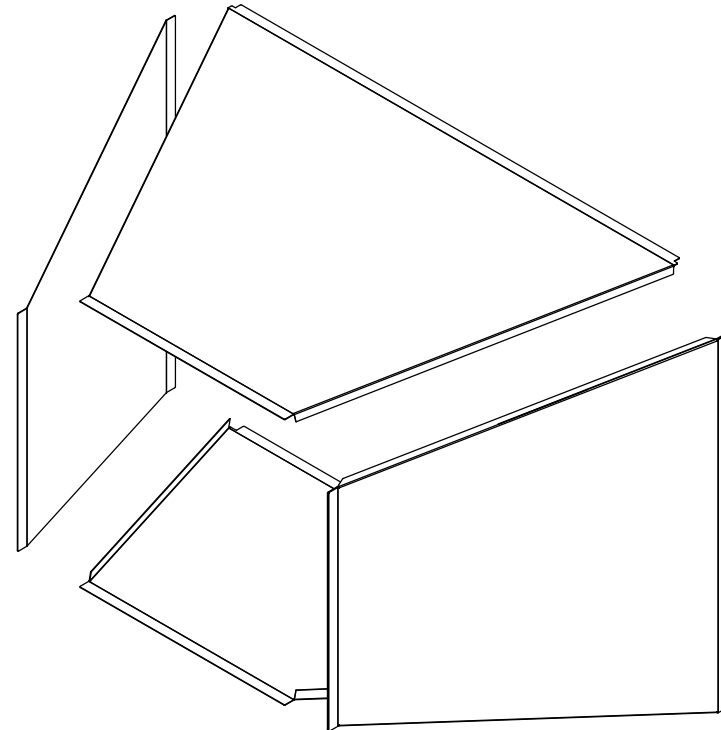
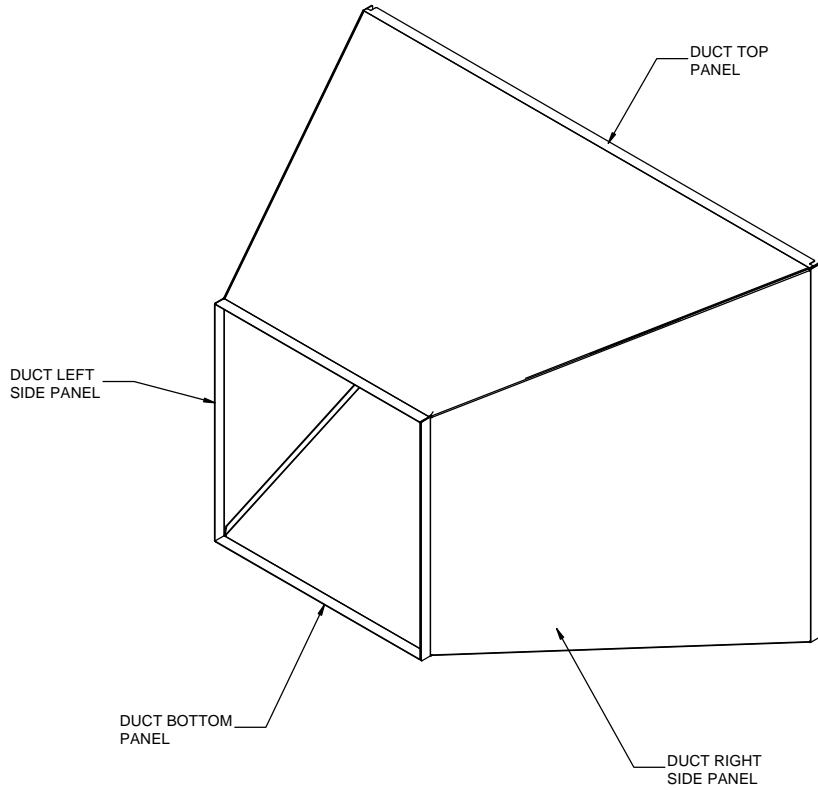

DUCT TRANSITION BY OTHERS.
 DUCT ASSEMBLY IS FOR REFERENCE ONLY!
 ALTERNATE CONSTRUCTION IS ACCEPTABLE.

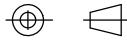
Desert Aire has a policy of continuous product and quality improvement. Specifications and dimensions are subject to change without notice. This drawing and information contained herein are the exclusive property of the Desert Aire Corporation. Any use detrimental to the interests of Desert Aire is prohibited.	All Dimensions in Inches All Angles 90° All outside corners 0.125" fillet Unless Otherwise Specified	Tolerance Unless Otherwise Specified X.X ±.125 X.XX ±.060 X.XXX ±.030 Angles ±1°	 N120 W18485 FREISTADT RD GERMANTOWN, WI 53022 Tel: (262) 946-7400 Fax: (262) 946-7401
ALL DIMENSIONS ARE IN INCHES TOLERANCE ± 1/8"	 Third Angle Projection	Sheet: 6/6	Page Title: UNIT TO HEATER DUCT
		Part weight:	Scale: NTS Rev: 2 Drawing Number: G900-001-G