

AIR FLOW	UNIT CABINET SIZES	UNIT SIZE (TONS)	L1	W1	H1	L2	W2	H3	H4
DOWN FLOW	50	08	158 7/8	61 3/8	50	182 5/8	73 3/8	13	11 7/8
		10	158 7/8	61 3/8	50	182 5/8	73 3/8	13	11 7/8
		12	158 7/8	61 3/8	50	182 5/8	73 3/8	13	11 7/8
		15	158 7/8	61 3/8	50	182 5/8	73 3/8	13	11 7/8
DOWN FLOW	82	20	184 1/2	94 1/4	73 1/8	203 1/2	106	17 1/4	21 3/8
		25	184 1/2	94 1/4	73 1/8	203 1/2	106	17 1/4	21 3/8
		30	208 1/2	94 1/4	73 1/8	227 1/2	106	17 1/4	21 3/8

UNIT CABINET SIZES	UNIT SIZE (TONS)	A	B	C
50	08	18 7/8	30 3/8	N/A
	10	18 7/8	30 3/8	N/A
	12	18 7/8	30 3/8	N/A
	15	18 7/8	30 3/8	N/A
82	20	38 1/4	33 3/8	61 1/8
	25	38 1/4	33 3/8	61 1/8
	30	38 1/4	33 3/8	61 1/8

OUTDOOR AIR INTAKE VIEW 5 4

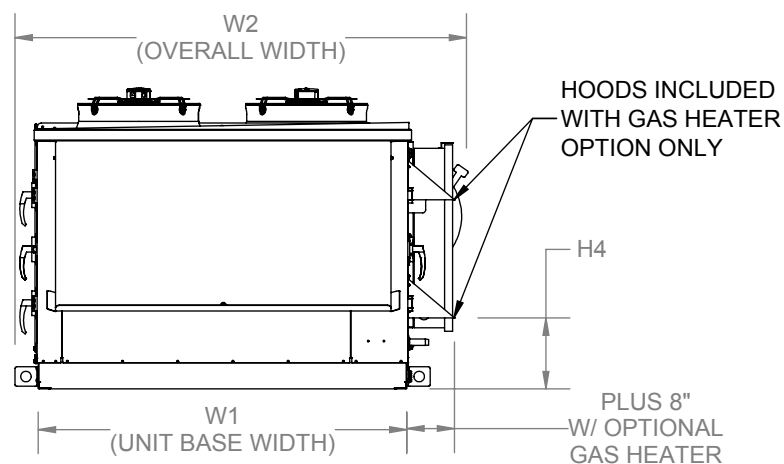

RIGHT SIDE VIEW 4

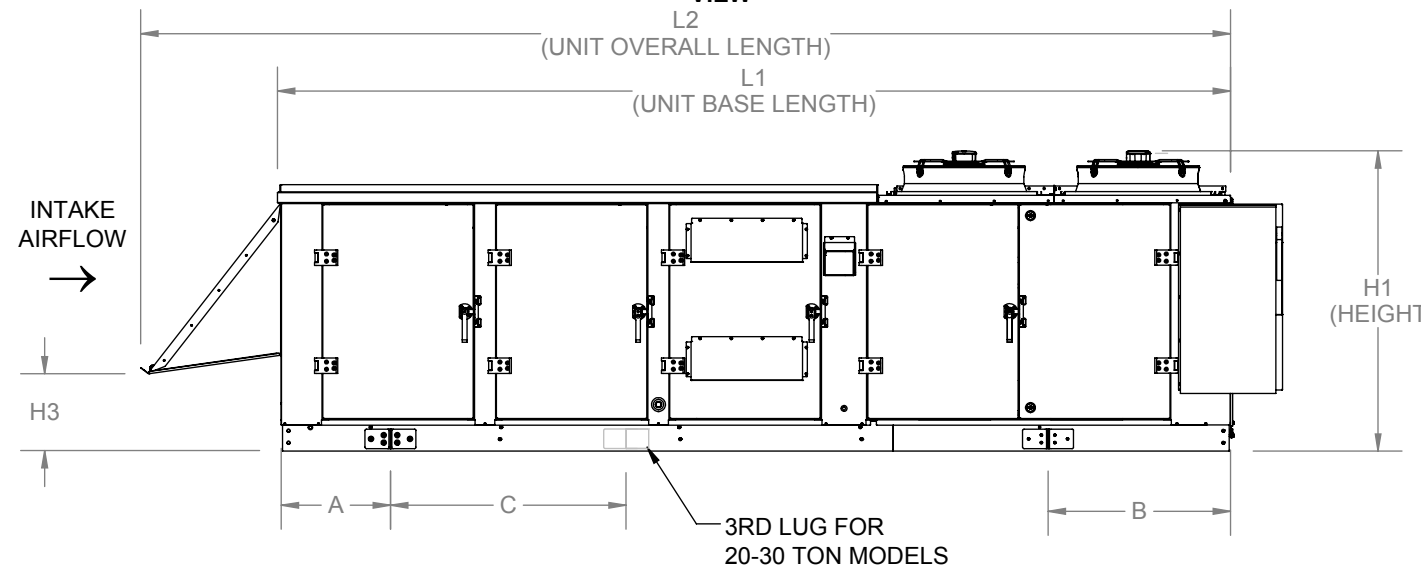

GENERAL NOTES AS REFERENCED BY INDIVIDUAL SHEETS:

- 1 PORTION OF SECTIONED OR DETAILED DRAWING HAS BEEN OMITTED FOR CLARITY.
- 2 HOODS OMITTED FOR CLARITY.
- 3 VIEW IS FOR PICTORIAL PURPOSES. REFER TO PAGE 1 FOR UNIT TYPE SPECIFIC VIEW.
- 4 GAS HEAT OPTION SHOWN.
- 5 15 TON UNIT SHOWN. CONDENSER FAN QUANTITY MAY VARY BY TONNAGE.
- 6 SHOWN WITH RETURN AIR OPTION.

Desert Aire has a policy of continuous product and quality improvement. Specifications and dimensions are subject to change without notice. This drawing and information contained herein are the exclusive property of the Desert Aire Corporation. Any use detrimental to the interests of Desert Aire is prohibited.	All Dimensions in Inches All Angles 90° All outside corners 0.125" fillet Unless Otherwise Specified	Tolerance Unless Otherwise Specified X.X ±.125 X.XX ±.060 X.XXX ±.030 Angles ±1°	N120 W18485 FREISTADT RD GERMANTOWN, WI 53022 Tel: (262) 946-7400 Fax: (262) 946-7401
ALL DIMENSIONS ARE IN INCHES TOLERANCE ± 1/8"	Third Angle Projection	Sheet: 1/9	Page Title: GENERAL ARRANGEMENT
Part weight	Scale: NTS	Rev: 14	Drawing Number: G806-001

**BOTTOM CUSTOMER CONNECTIONS
(VIEWED FROM ABOVE)**

1 2 6

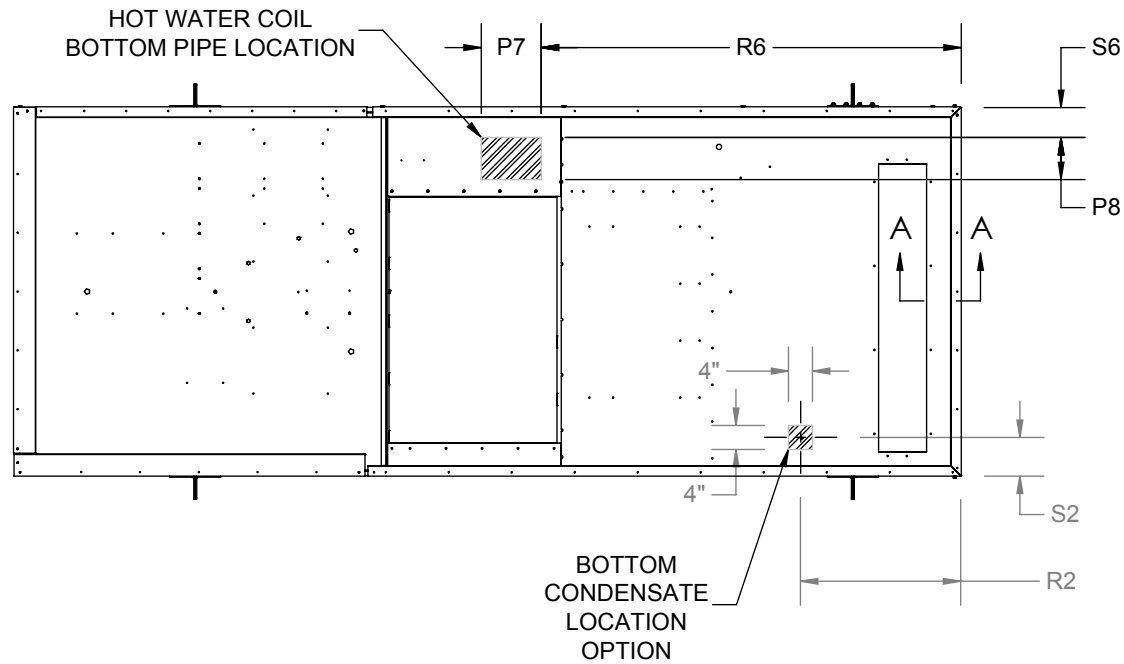

LEFT SIDE CONNECTION VIEW

5

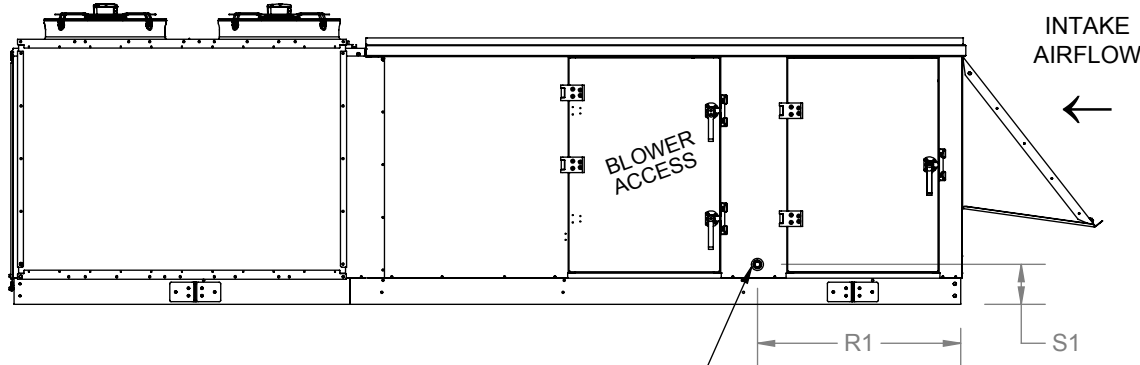

FRONT CONNECTIONS VIEW

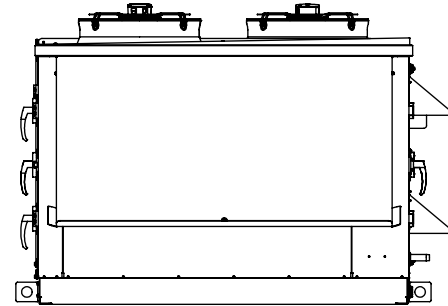

RIGHT SIDE CONNECTION VIEW

4

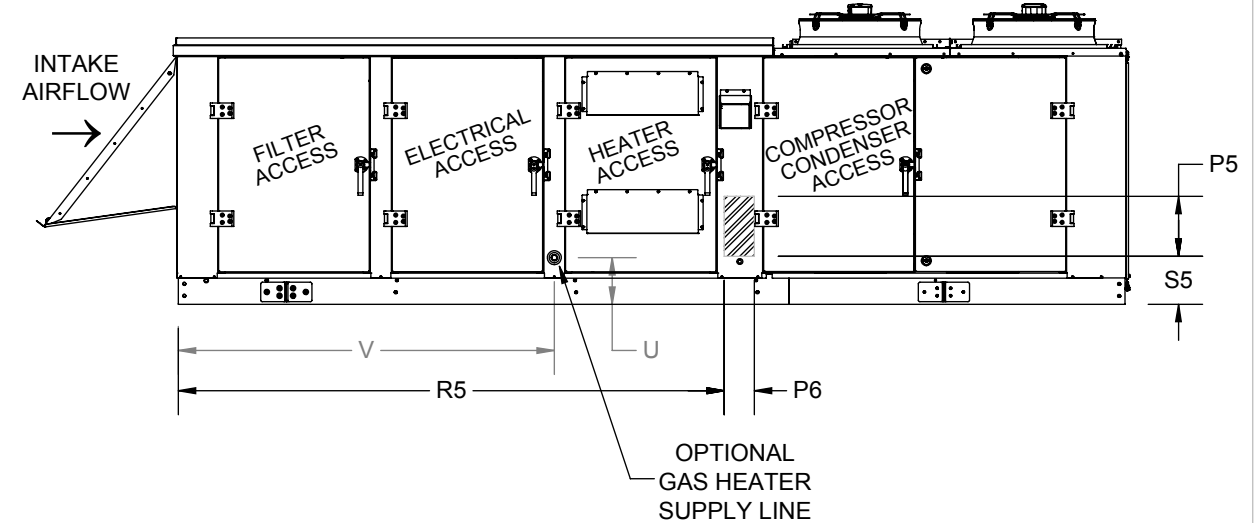

1 6

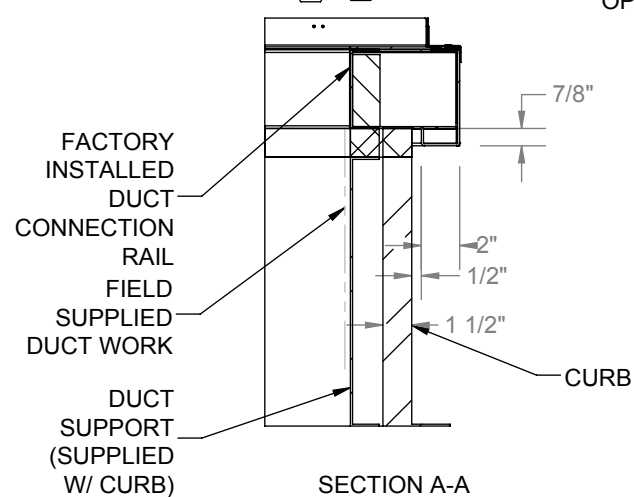

SECTION A-A
SCALE 1 : 10

AIR FLOW	UNIT CABINET SIZES	UNIT SIZE (TONS)	R1	S1	R2	S2	U	V	P7	P8	R6	S6	P5	P6	R5	S5
DOWN FLOW	50	08	34	6 5/8	26 3/4	6 3/8	7 3/4	62 7/8	10	7	70	5	10	6	91	8
		10	34	6 5/8	26 3/4	6 3/8	7 3/4	62 7/8	10	7	70	5	10	6	91	8
		12	34	6 5/8	26 3/4	6 3/8	7 3/4	62 7/8	10	7	70	5	10	6	91	8
		15	34	6 5/8	26 3/4	6 3/8	7 3/4	62 7/8	10	7	70	5	10	6	91	8
DOWN FLOW	82	20	27 7/8	8 5/8	33 3/4	6 5/8	8 3/4	81 3/4	12	8	84	4 1/2	8	8	117 1/4	20
		25	27 7/8	8 5/8	33 3/4	6 5/8	8 3/4	81 3/4	12	8	84	4 1/2	8	8	117 1/4	20
		30	27 7/8	8 5/8	33 3/4	6 5/8	8 3/4	81 3/4	12	8	84	4 1/2	8	8	117 1/4	20

CUSTOMER CONNECTION LINE SIZE (in.)							
UNIT SIZE	8 TONS	10 TONS	12 TONS	15 TONS	20 TONS	25 TONS	30 TONS
CONDENSATE (PVC)	3/4	3/4	3/4	3/4	1 1/2	1 1/2	1 1/2
HOT WATER COIL	1 5/8	1 5/8	1 5/8	1 5/8	2 1/8	2 1/8	2 1/8
GAS (MNPT)	3/4	3/4	3/4	3/4	1	1	1

NOTES:
REFER TO SHEET 1 FOR GENERAL NOTES.

Desert Aire has a policy of continuous product and quality improvement. Specifications and dimensions are subject to change without notice. This drawing and information contained herein are the exclusive property of the Desert Aire Corporation. Any use detrimental to the interests of Desert Aire is prohibited.

All Dimensions in Inches
All Angles 90°
All outside corners 0.125" fillet
Unless Otherwise Specified

Tolerance Unless Otherwise Specified
X.X ±.125
X.XX ±.060
X.XXX ±.030
Angles ±1°

DESERT AIRE
N120 W18485 FREISTADT RD
GERMANTOWN, WI 53022
Tel: (262) 946-7400
Fax: (262) 946-7401

Third Angle Projection

ALL DIMENSIONS ARE IN INCHES
TOLERANCE ± 1/8"

Part weight

Drawn	MHB	Date Released	9/8/2011	Description	AURA AIR COOLED PKGD
Sheet	2/9		Page Title	CUSTOMER INTERFACE GA	
Scale	NTS	Rev.	14	Drawing Number	G806-001

TOP VIEW BOTTOM CUSTOMER CONNECTIONS

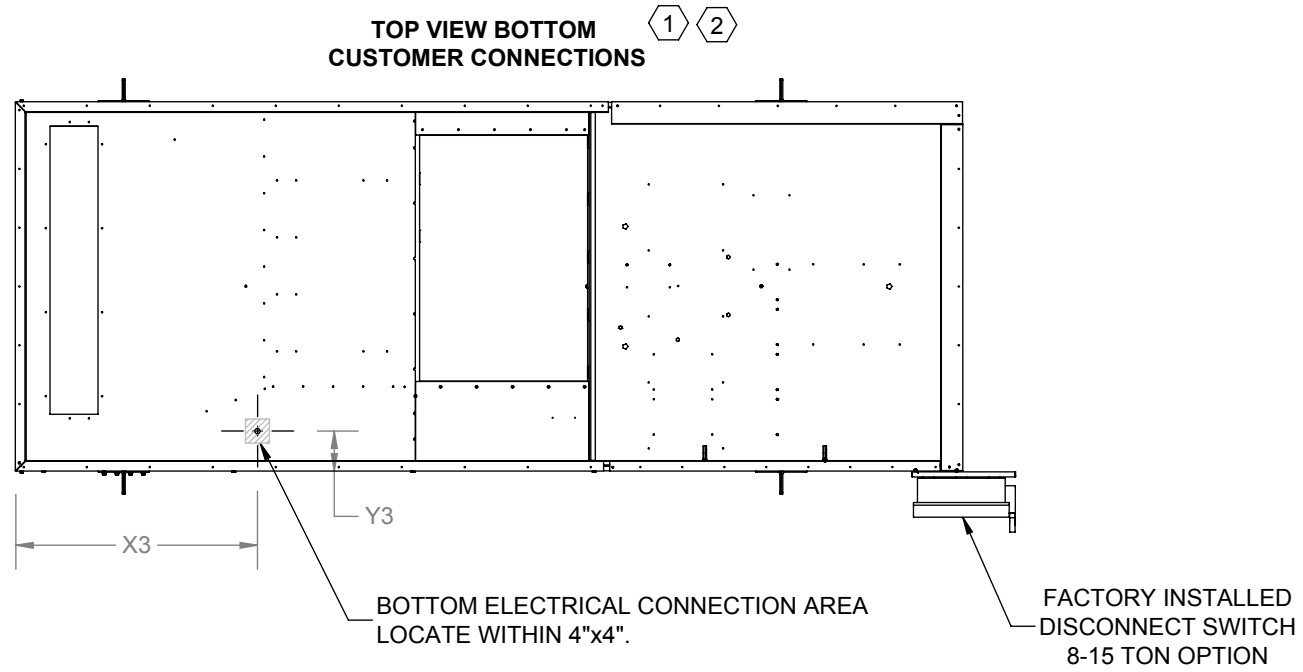

DISCONNECT RATING AMPS	X1
30	1 7/8
60	1 7/8
100	1 7/8
200	8 3/4

AIR FLOW	UNIT CABINET SIZES	UNIT SIZE (TONS)	X2	Y2	X3	Y3
DOWN FLOW	50	08	34	7 1/4	40 3/8	6 1/2
		10	34	7 1/4	40 3/8	6 1/2
		12	34	7 1/4	40 3/8	6 1/2
		15	34	7 1/4	40 3/8	6 1/2
DOWN FLOW	82	20	41 1/2	8 3/4	51 3/8	6 5/8
		25	41 1/2	8 3/4	51 3/8	6 5/8
		30	41 1/2	8 3/4	51 3/8	6 5/8

ELECTRICAL SIDE CONNECTIONS FRONT VIEW

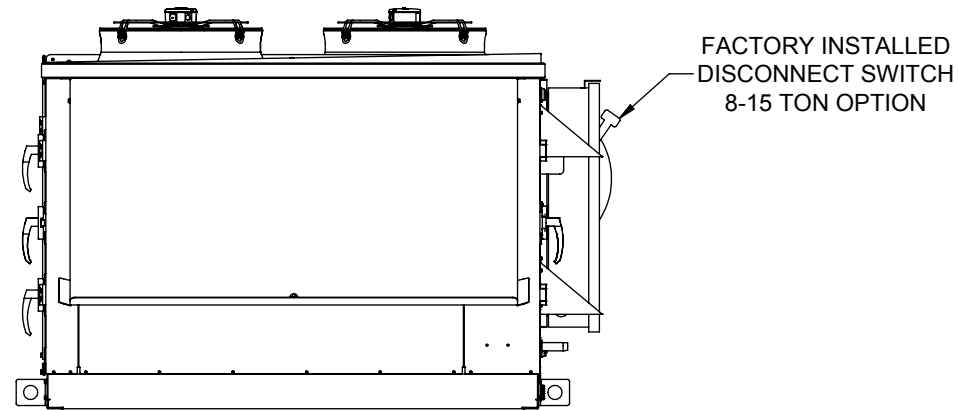

ELECTRICAL SIDE CONNECTIONS SIDE VIEW

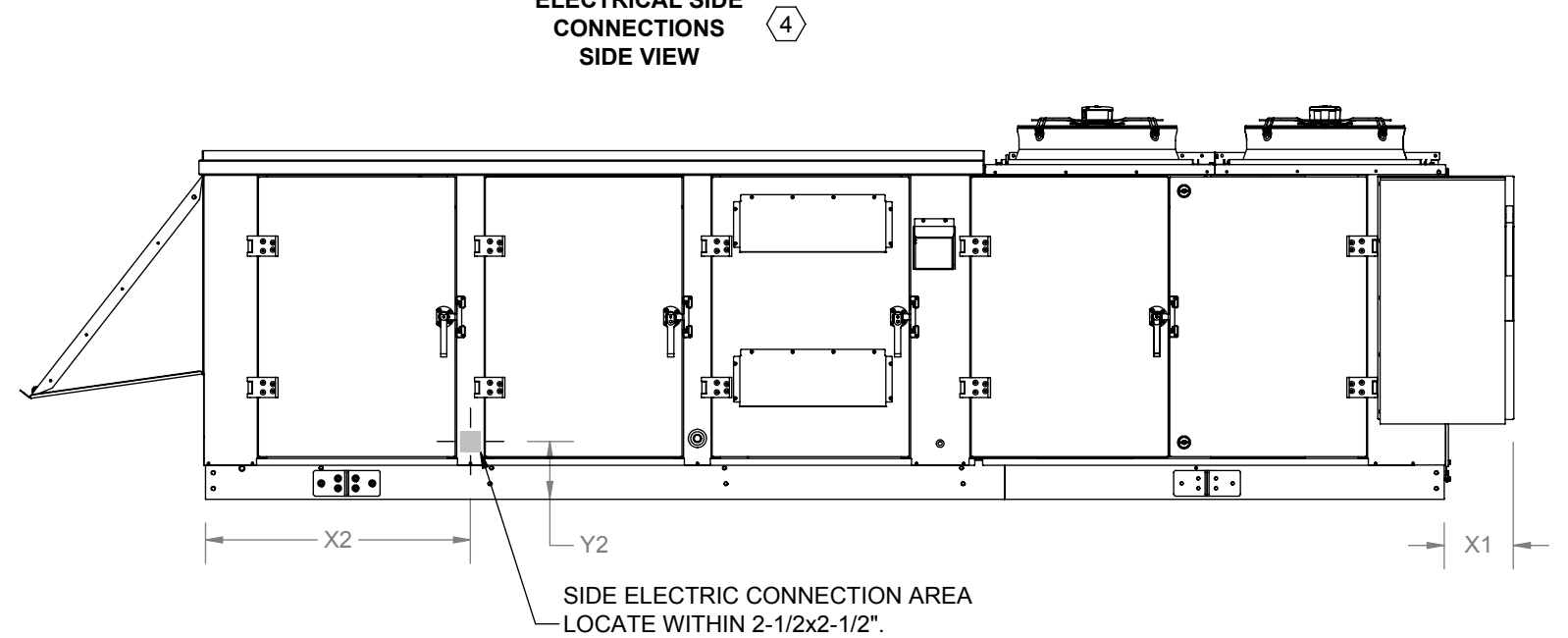

Desert Aire has a policy of continuous product and quality improvement. Specifications and dimensions are subject to change without notice. This drawing and information contained herein are the exclusive property of the Desert Aire Corporation. Any use detrimental to the interests of Desert Aire is prohibited.

All Dimensions in Inches
All Angles 90°
All outside corners 0.125" fillet
Unless Otherwise Specified

Tolerance Unless Otherwise Specified
X.X ±.125
X.XX ±.060
X.XXX ±.030
Angles ±1°

DESERT AIRE
N120 W18485 FREISTADT RD
GERMANTOWN, WI 53022
Tel: (262) 946-7400
Fax: (262) 946-7401



Third Angle Projection

ALL DIMENSIONS ARE IN INCHES
TOLERANCE ± 1/8"

Part weight

Drawn	Date Released	Description
MHB	9/8/2011	AURA AIR COOLED PKGD
Sheet	3/9	Page Title
Scale	Rev.	Drawing Number
NTS	14	G806-001

NOTES:

REFER TO SHEET 1 FOR GENERAL NOTES.

WEIGHTS SHOWN REFLECT FULLY OPTIONED ESTIMATED UNIT WEIGHT.

REFER TO CURB DETAILS GA SHEETS FOR SUPPLY DUCT DIMENSION AND LOCATIONS.

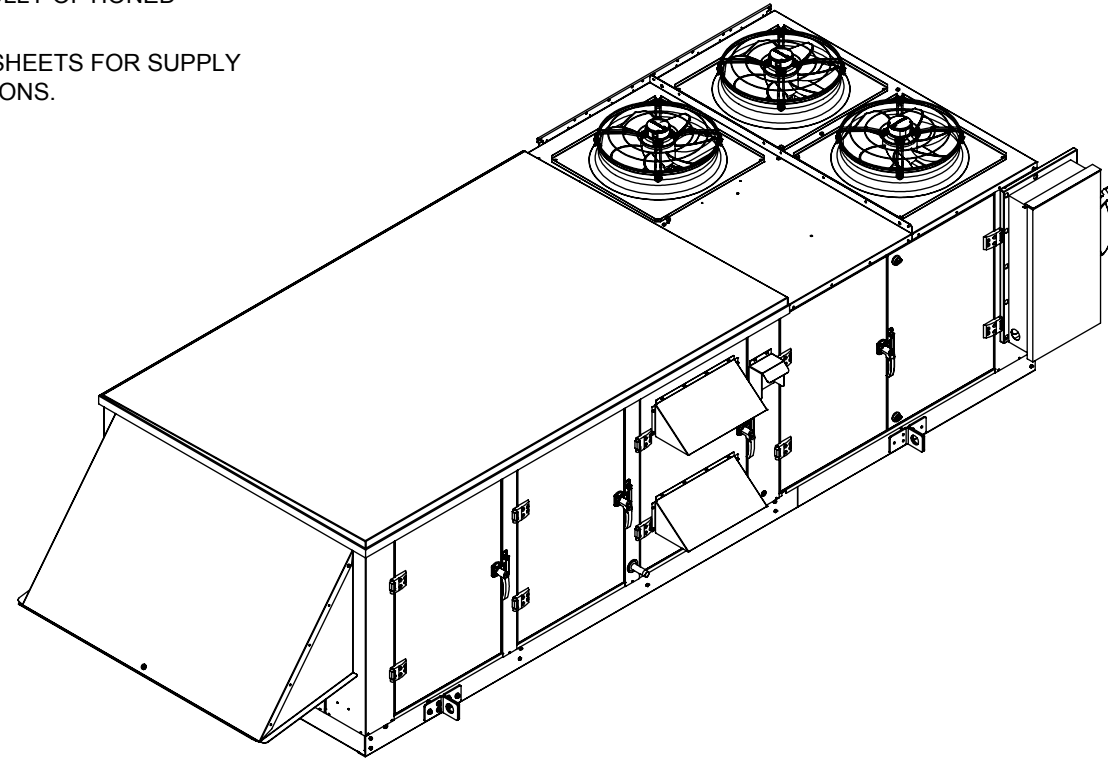

DISCHARGE RETURN VIEW 3 4 5

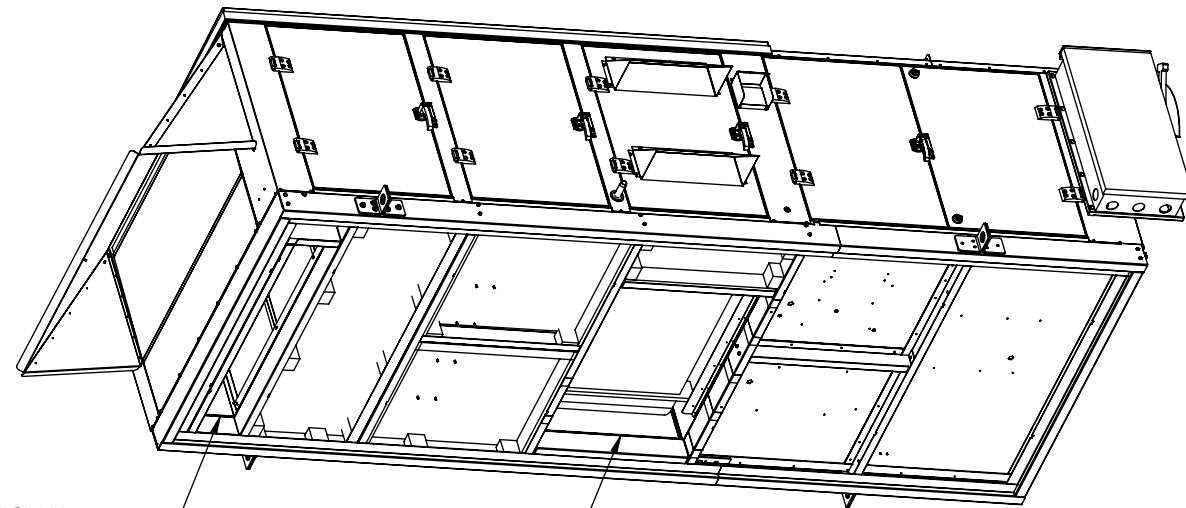

OPTIONAL RETURN INTAKE (REFER TO CURB DETAILS GA SHEET FOR DIMENSIONS)

SUPPLY DISCHARGE (REFER TO CURB DETAILS GA SHEET FOR DIMENSIONS)

UNIT CABINET SIZES	UNIT SIZE (TONS)	DOWN DISCHARGE, DOWN RETURN	FOR 1-GAS HEATER ADD (LBS)	FOR 2-GAS HEATER ADD (LBS)	FOR ELECTRIC HEATER ADD (LBS)	FILTER QTY	FILTER SIZE
		ESTIMATED BASE WEIGHT (LBS)					
50	08	2120	345	NA	170	6	20x16x4
	10	2222	345	NA	170	6	20x16x4
	12	2233	345	NA	170	6	20x16x4
	15	2242	345	NA	170	6	20x16x4
82	20	4063	487	598	240	8	24x20x4
	25	4114	487	598	240	8	24x20x4
	30	4580	487	598	240	8	24x20x4

NOTE: TO CALCULATE THE UNIT WEIGHT ADD THE BASE WEIGHT TO THE CORRECT HEATER OPTION WEIGHT (DO NOT COMBINE HEATERS).

Desert Aire has a policy of continuous product and quality improvement. Specifications and dimensions are subject to change without notice. This drawing and information contained herein are the exclusive property of the Desert Aire Corporation. Any use detrimental to the interests of Desert Aire is prohibited.

All Dimensions in Inches
All Angles 90°
All outside corners 0.125" fillet
Unless Otherwise Specified

Tolerance Unless Otherwise Specified
X.X ±.125
X.XX ±.060
X.XXX ±.030
Angles ±1°

DESERT AIRE
N120 W18485 FREISTADT RD
GERMANTOWN, WI 53022
Tel: (262) 946-7400
Fax: (262) 946-7401

Third Angle Projection

Drawn	Date Released	Description
MHB	9/8/2011	AURA AIR COOLED PKGD

ALL DIMENSIONS ARE IN INCHES
TOLERANCE ± 1/8"

Sheet	Page Title
4/9	DOWN DISCHARGE GA

Part weight	Scale	Rev.	Drawing Number
	NTS	14	G806-001

TOP VIEW
LEFT DISCHARGE
CONNECTION

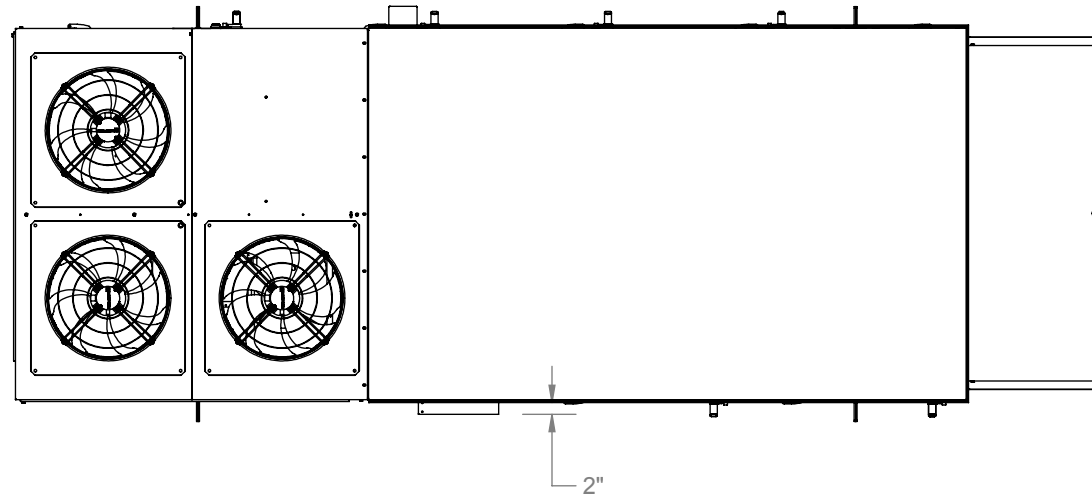

LEFT DISCHARGE
CONNECTION
VIEW

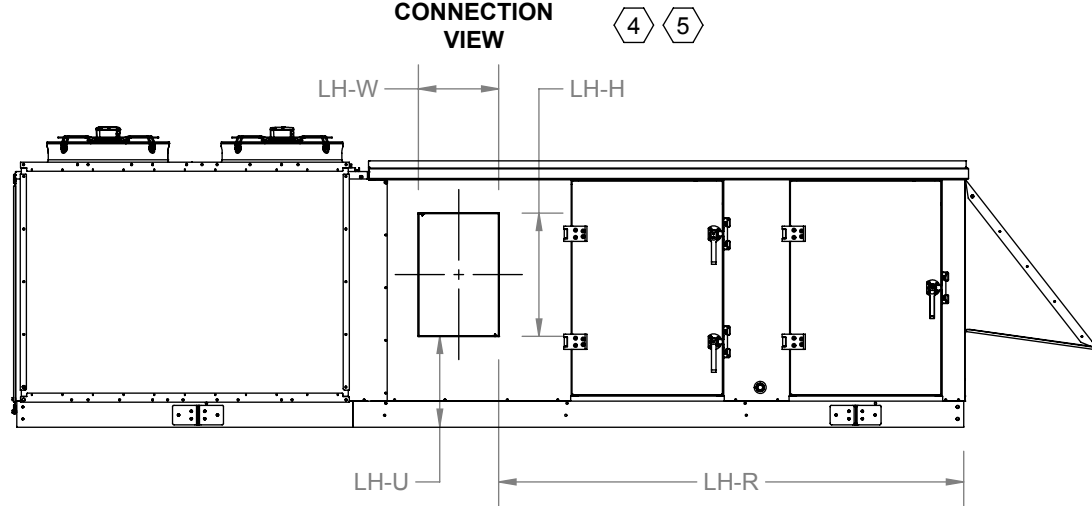

UNIT CABINET SIZES	UNIT SIZE (TONS)	SIDE SUPPLY DISCHARGE (in.)			
		LH-W	LH-H	LH-U	LH-R
50	08	13 3/8	20 1/2	15 1/8	77 1/2
	10	13 3/8	20 1/2	15 1/8	77 1/2
	12	13 3/8	20 1/2	15 1/8	77 1/2
	15	13 3/8	20 1/2	15 1/8	77 1/2
82	20	20 1/8	40 1/8	13 1/4	102
	25	20 1/8	40 1/8	13 1/4	102
	30	20 1/8	40 1/8	13 1/4	102

NOTES:
REFER TO SHEET 1 FOR GENERAL NOTES.

REFER TO CURB DETAILS GA SHEETS FOR RETURN DUCT DIMENSION AND LOCATIONS.

THE STANDARD AND RETURN AIR CURBS SHOULD BE USED.

Desert Aire has a policy of continuous product and quality improvement. Specifications and dimensions are subject to change without notice. This drawing and information contained herein are the exclusive property of the Desert Aire Corporation. Any use detrimental to the interests of Desert Aire is prohibited.

All Dimensions in Inches
All Angles 90°
All outside corners 0.125" fillet
Unless Otherwise Specified

Tolerance Unless Otherwise Specified
X.X ±.125
X.XX ±.060
X.XXX ±.030
Angles ±1°



N120 W18485 FREISTADT RD
GERMANTOWN, WI 53022
Tel: (262) 946-7400
Fax: (262) 946-7401

Third Angle Projection

Part weight

ALL DIMENSIONS ARE IN INCHES
TOLERANCE ± 1/8"

Drawn	Date Released	Description
MHB	9/8/2011	AURA AIR COOLED PKGD
Sheet	5/9	Page Title
		LEFT DISCHARGE GA
Scale	Rev.	Drawing Number
NTS	14	G806-001

NOTES:
REFER TO SHEET 1 FOR GENERAL NOTES.

1. 18 GA. GALVANIZED STEEL CONSTRUCTION.
2. KNOCK DOWN CURB.
3. PRIME PAINTED.
4. PRESSURE TREATED 2X2 WOOD NAILER.
5. 1-1/2" THICK 3LB/FT³ FIBERGLASS PERIMETER INSULATION.
6. INTERNAL ANGLE REINFORCEMENT.

UNIT CABINET SIZES	UNIT SIZE (TONS)	2 PIECE CURB					SUPPLY DISCHARGE (in.)				RETURN INTAKE (in.)			
		CURB P/N STANDARD	CURB P/N W/ RA	WIDTH (in.)	LENGTH (in.)	SUPPORT LENGTH (in.)	A	B	C	D	E	F	G	H
50	08	CB08MPC105-XX2	CB08MPF105-XX2	56 1/2	94 1/4	52 1/4	1 1/2	28	12 1/2	41	3 1/4	8	7	48
	10	CB10MPC105-XX2	CB10MPF105-XX2	56 1/2	94 1/4	52 1/4	1 1/2	28	12 1/2	41	3 1/4	8	7	48
	12	CB12MPC105-XX2	CB12MPF105-XX2	56 1/2	94 1/4	52 1/4	1 1/2	28	12 1/2	41	3 1/4	8	7	48
	15	CB15MPC105-XX2	CB15MPF105-XX2	56 1/2	94 1/4	52 1/4	1 1/2	28	12 1/2	41	3 1/4	8	7	48
82	20	CB20MPC105-XX2	CB20MPF105-XX2	89 1/4	125 3/4	48	1 1/2	28	12 7/8	74	3 1/4	12	7 3/4	80
	25	CB25MPC105-XX2	CB25MPF105-XX2	89 1/4	125 3/4	48	1 1/2	28	12 7/8	74	3 1/4	12	7 3/4	80
	30	CB30MPC105-XX2	CB30MPF105-XX2	89 1/4	125 3/4	72	1 1/2	28	12 7/8	74	3 1/4	12	7 3/4	80

2-PC CURB TOP VIEW ① ② ⑥

ALL DIMENSIONS ARE FROM THE TOP OF THE CURB PERIMETER (ROOF FLANGE OMITTED FOR CLARITY)

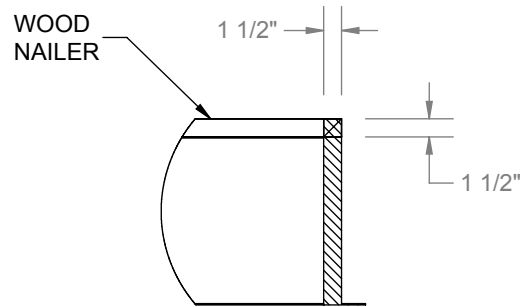
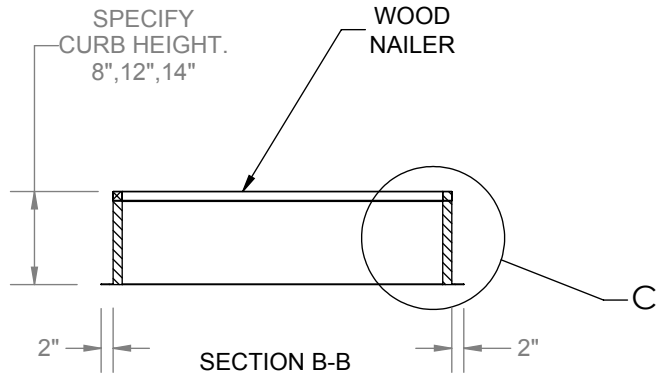
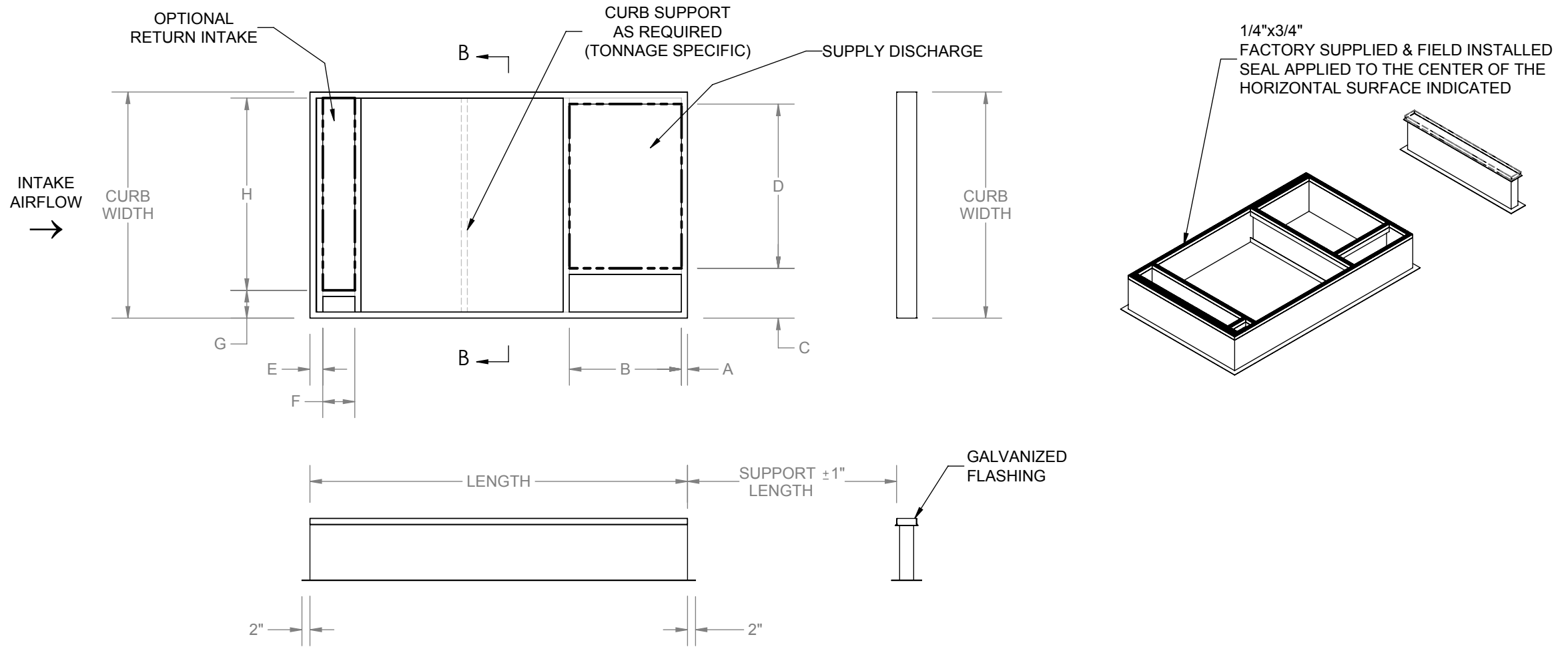

DETAIL C
SCALE 1 : 16

Desert Aire has a policy of continuous product and quality improvement. Specifications and dimensions are subject to change without notice. This drawing and information contained herein are the exclusive property of the Desert Aire Corporation. Any use detrimental to the interests of Desert Aire is prohibited.	All Dimensions in Inches All Angles 90° All outside corners 0.125" fillet Unless Otherwise Specified	Tolerance Unless Otherwise Specified X.X ±.125 X.XX ±.060 X.XXX ±.030 Angles ±1°	N120 W18485 FREISTADT RD GERMANTOWN, WI 53022 Tel: (262) 946-7400 Fax: (262) 946-7401
ALL DIMENSIONS ARE IN INCHES TOLERANCE ± 1/8"	Third Angle Projection	Sheet: 6/9	Page Title: 2-PC CURB DETAIL GA
		Scale: NTS	Rev: 14 Drawing Number: G806-001

NOTES:
REFER TO SHEET 1 FOR GENERAL NOTES.

1. 14 GA. GALVANIZED STEEL CONSTRUCTION.
2. FULLY WELDED WATERTIGHT ONE PIECE CURB.
3. PRIME PAINTED AFTER FABRICATION.
4. PRESSURE TREATED 1X4 WOOD NAILER.
5. THE CURB HAS 1-1/2" THICK 3LB/FT³ FIBERGLASS PERIMETER INSULATION.
THE PAN ALSO HAS 1" THICK 3LB/FT³ FIBERGLASS PAN INSULATION.
6. INTERNAL ANGLE REINFORCEMENT.

UNIT CABINET SIZES	UNIT SIZE (TONS)	1 PIECE SLOPING PAN CURB				SUPPLY DISCHARGE (in.)				RETURN INTAKE (in.)			
		CURB P/N STANDARD	CURB P/N W/ RA	WIDTH (in.)	LENGTH (in.)	A	B	C	D	E	F	G	H
50	08	CB08MPC105-XX1	CB08MPF105-XX1	56 1/2	152 3/4	60	28	12 1/2	41	3 1/4	8	7	48
	10	CB10MPC105-XX1	CB10MPF105-XX1	56 1/2	152 3/4	60	28	12 1/2	41	3 1/4	8	7	48
	12	CB12MPC105-XX1	CB12MPF105-XX1	56 1/2	152 3/4	60	28	12 1/2	41	3 1/4	8	7	48
	15	CB15MPC105-XX1	CB15MPF105-XX1	56 1/2	152 3/4	60	28	12 1/2	41	3 1/4	8	7	48
82	20	CB20MPC105-XX1	CB20MPF105-XX1	89 1/4	179	54 7/8	28	12 7/8	74	3 3/4	12	7 3/4	80
	25	CB25MPC105-XX1	CB25MPF105-XX1	89 1/4	179	54 7/8	28	12 7/8	74	3 3/4	12	7 3/4	80
	30	CB30MPC105-XX1	CB30MPF105-XX1	89 1/4	203	78 7/8	28	12 7/8	74	3 3/4	12	7 3/4	80

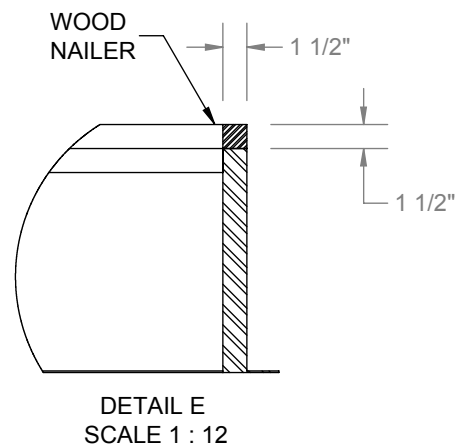
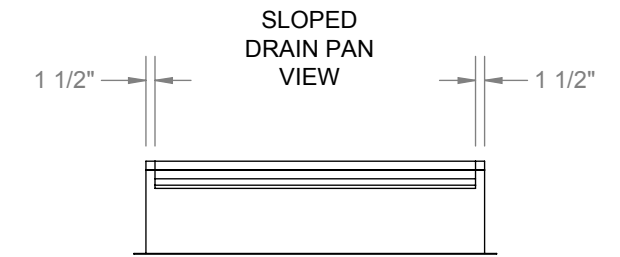
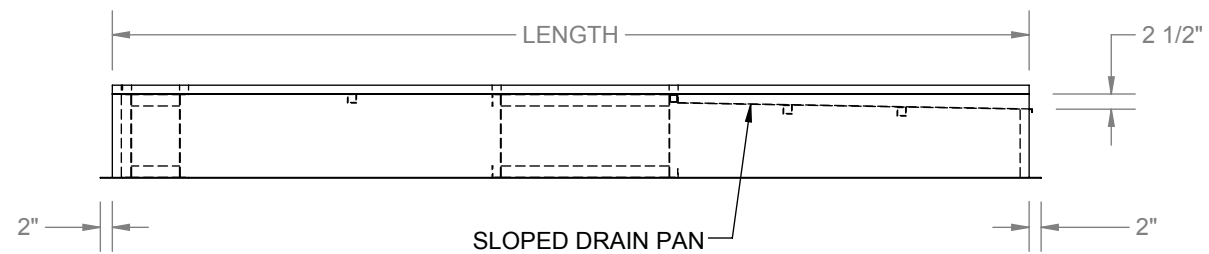
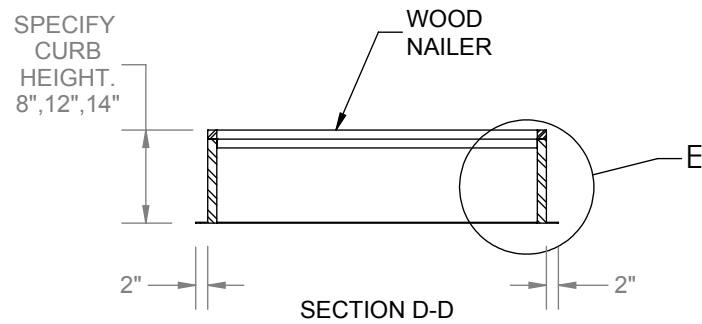
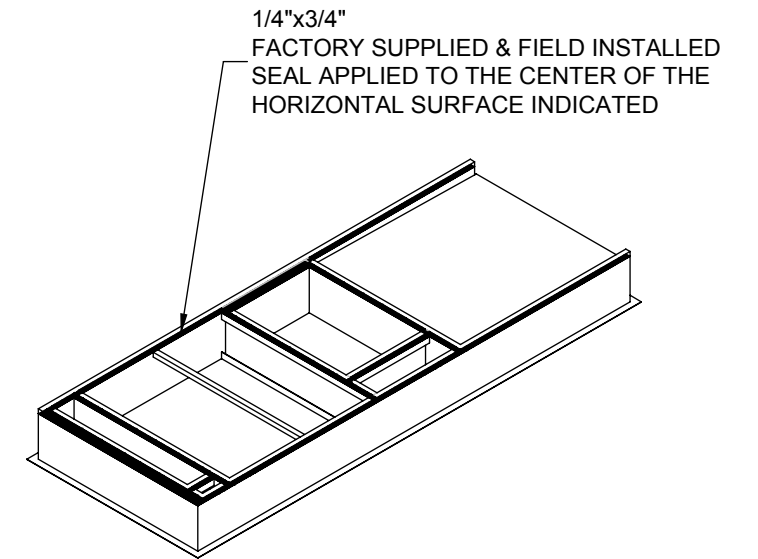
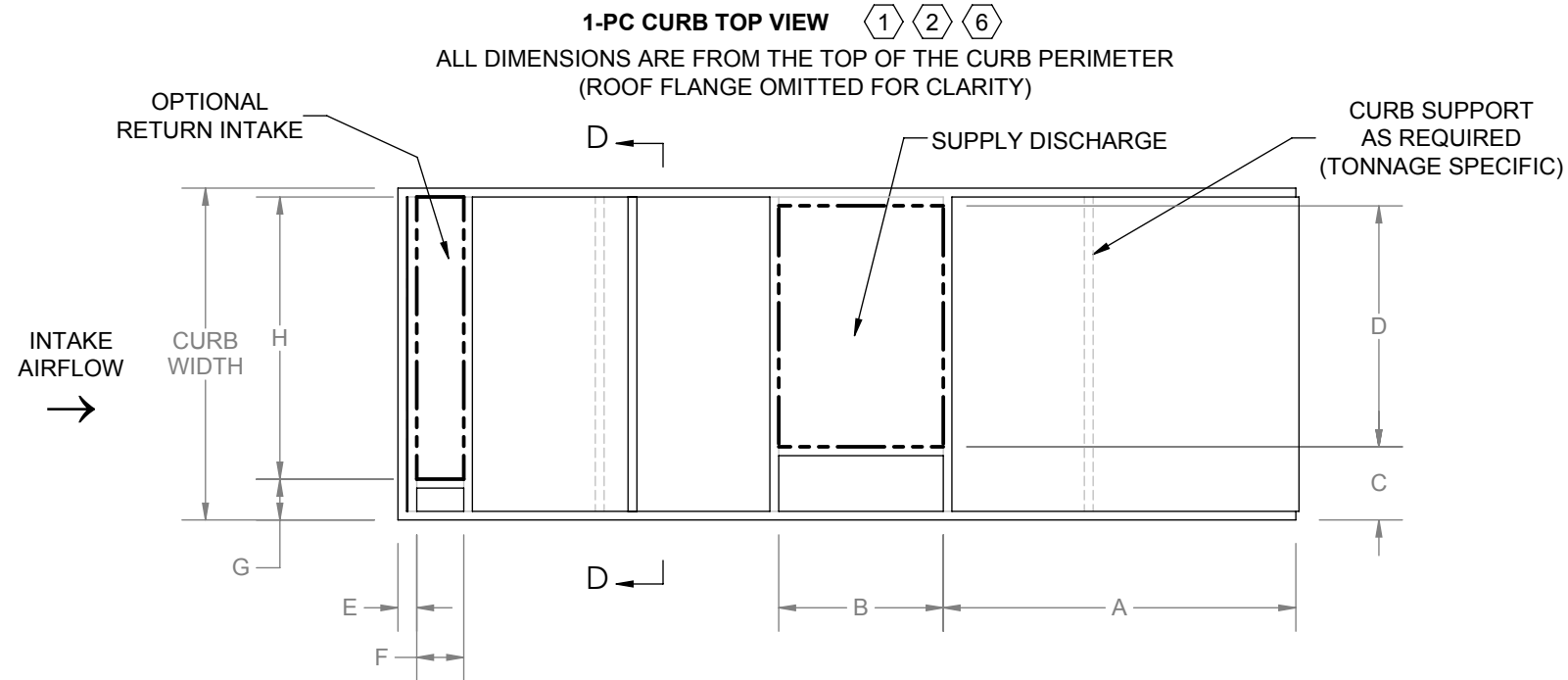

--- DUCT CONNECTIONS FOR DOWN DISCHARGE / DOWN RETURN

Desert Aire has a policy of continuous product and quality improvement. Specifications and dimensions are subject to change without notice. This drawing and information contained herein are the exclusive property of the Desert Aire Corporation. Any use detrimental to the interests of Desert Aire is prohibited.

All Dimensions in Inches
All Angles 90°
All outside corners 0.125" fillet
Unless Otherwise Specified

Tolerance Unless Otherwise Specified
X.X ±.125
X.XX ±.060
X.XXX ±.030
Angles ±1°

DESERT AIRE
N120 W18485 FREISTADT RD
GERMANTOWN, WI 53022
Tel: (262) 946-7400
Fax: (262) 946-7401



Third Angle Projection

Part weight

ALL DIMENSIONS ARE IN INCHES
TOLERANCE ± 1/8"

Drawn	Date Released	Description
MHB	9/8/2011	AURA AIR COOLED PKGD
Sheet	7/9	Page Title
		1-PC DOWN CURB DISCHARGE
Scale	Rev.	Drawing Number
NTS	14	G806-001

NOTES:
REFER TO SHEET 1 FOR GENERAL NOTES.

1. 14 GA. GALVANIZED STEEL CONSTRUCTION.
2. FULLY WELDED WATERTIGHT ONE PIECE CURB.
3. PRIME PAINTED AFTER FABRICATION.
4. PRESSURE TREATED 1X4 WOOD NAILER.
5. THE CURB HAS 1-1/2" THICK 3LB/FT³ FIBERGLASS PERIMETER INSULATION. THE SUPPLY DUCT HAS 1-1/2" THICK 3LB/FT³ FIBERGLASS INSULATION. THE PAN HAS 1" THICK 3LB/FT³ FIBERGLASS PAN INSULATION.
6. INTERNAL ANGLE REINFORCEMENT.

UNIT CABINET SIZES	UNIT SIZE (TONS)	1 PIECE SLOPING PAN CURB				CURB SUPPLY INLET (in.)				RETURN INTAKE (in.)				SUPPLY DISCHARGE (in.)	
		CURB P/N STANDARD	CURB P/N W/ RA	WIDTH (in.)	LENGTH (in.)	A	B	C	D	E	F	G	H	EV	EH
50	08	CB08MPC105-XXH	CB08MPF105-XXH	56 1/2	152 3/4	60	28	12 1/2	41	3 1/4	8	7	48	10	30
	10	CB10MPC105-XXH	CB10MPF105-XXH	56 1/2	152 3/4	60	28	12 1/2	41	3 1/4	8	7	48	10	30
	12	CB12MPC105-XXH	CB12MPF105-XXH	56 1/2	152 3/4	60	28	12 1/2	41	3 1/4	8	7	48	10	30
	15	CB15MPC105-XXH	CB15MPF105-XXH	56 1/2	152 3/4	60	28	12 1/2	41	3 1/4	8	7	48	10	30
82	20	CB20MPC105-XXH	CB20MPF105-XXH	89 1/4	179	54 7/8	28	12 7/8	74	3 3/4	12	7 3/4	80	16	54
	25	CB25MPC105-XXH	CB25MPF105-XXH	89 1/4	179	54 7/8	28	12 7/8	74	3 3/4	12	7 3/4	80	16	54
	30	CB30MPC105-XXH	CB30MPF105-XXH	89 1/4	203	78 7/8	28	12 7/8	74	3 3/4	12	7 3/4	80	16	54

1-PC CURB TOP VIEW ① ② ⑥

ALL DIMENSIONS ARE FROM THE TOP OF THE CURB PERIMETER (ROOF FLANGE OMITTED FOR CLARITY)

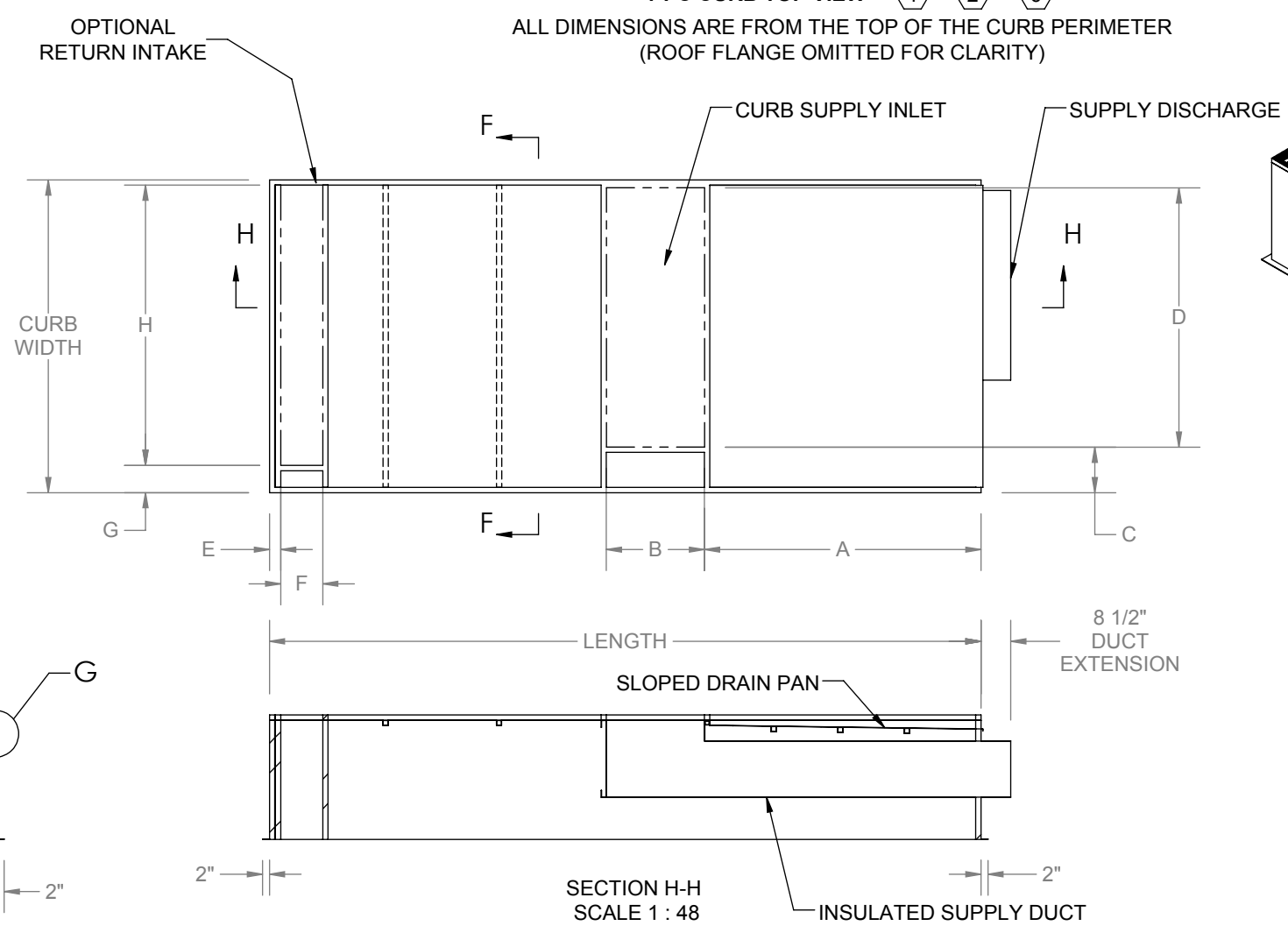

1/4"x3/4" FACTORY SUPPLIED & FIELD INSTALLED SEAL APPLIED TO THE CENTER OF THE HORIZONTAL SURFACE INDICATED

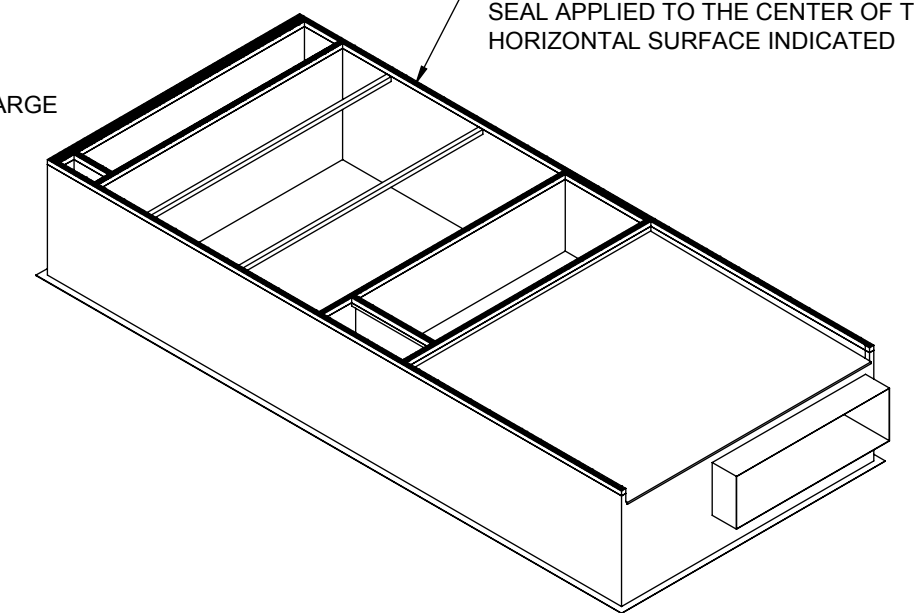

50 CABINET = 28"
82 CABINET = 34"
MIN HEIGHT

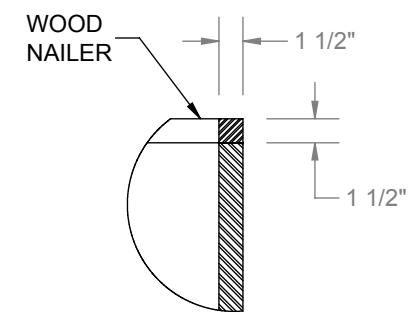
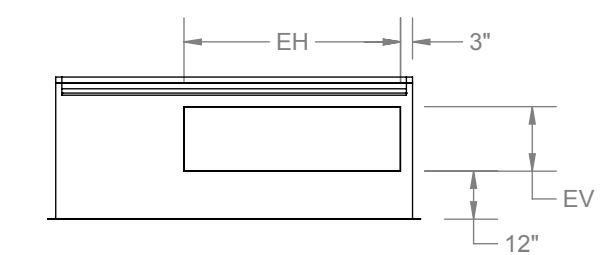
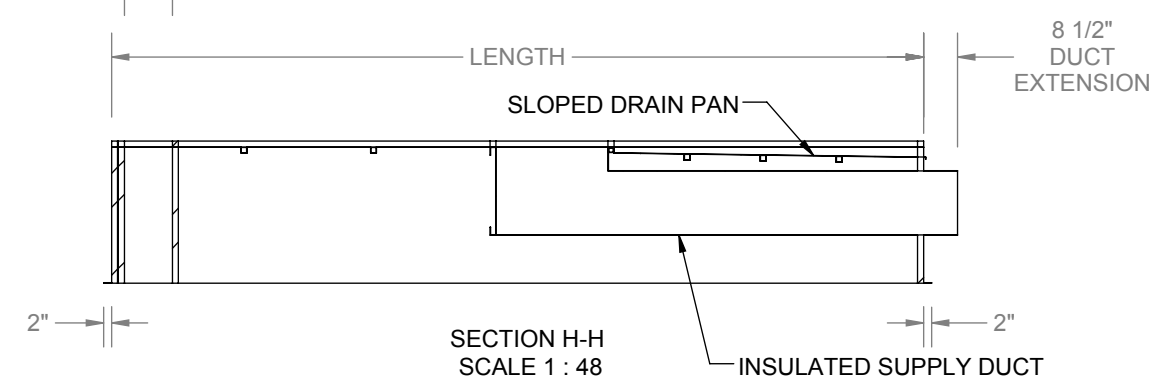
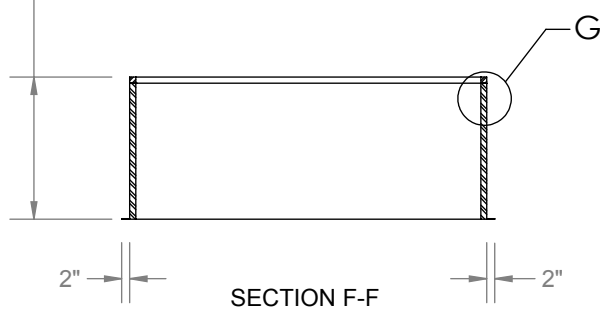

DETAIL G
SCALE 1 : 12

DUCT CONNECTIONS FOR DOWN DISCHARGE / DOWN RETURN

Desert Aire has a policy of continuous product and quality improvement. Specifications and dimensions are subject to change without notice. This drawing and information contained herein are the exclusive property of the Desert Aire Corporation. Any use detrimental to the interests of Desert Aire is prohibited.	All Dimensions in Inches All Angles 90° All outside corners 0.125" fillet Unless Otherwise Specified	Tolerance Unless Otherwise Specified X.X ±.125 X.XX ±.060 X.XXX ±.030 Angles ±1°	N120 W18485 FREISTADT RD GERMANTOWN, WI 53022 Tel: (262) 946-7400 Fax: (262) 946-7401
ALL DIMENSIONS ARE IN INCHES TOLERANCE ± 1/8"	Third Angle Projection	Sheet: 8/9 Scale: NTS Rev: 14	Page Title: 1-PC END CURB DISCHARGE Drawing Number: G806-001

TWO PIECE CURB DETAIL

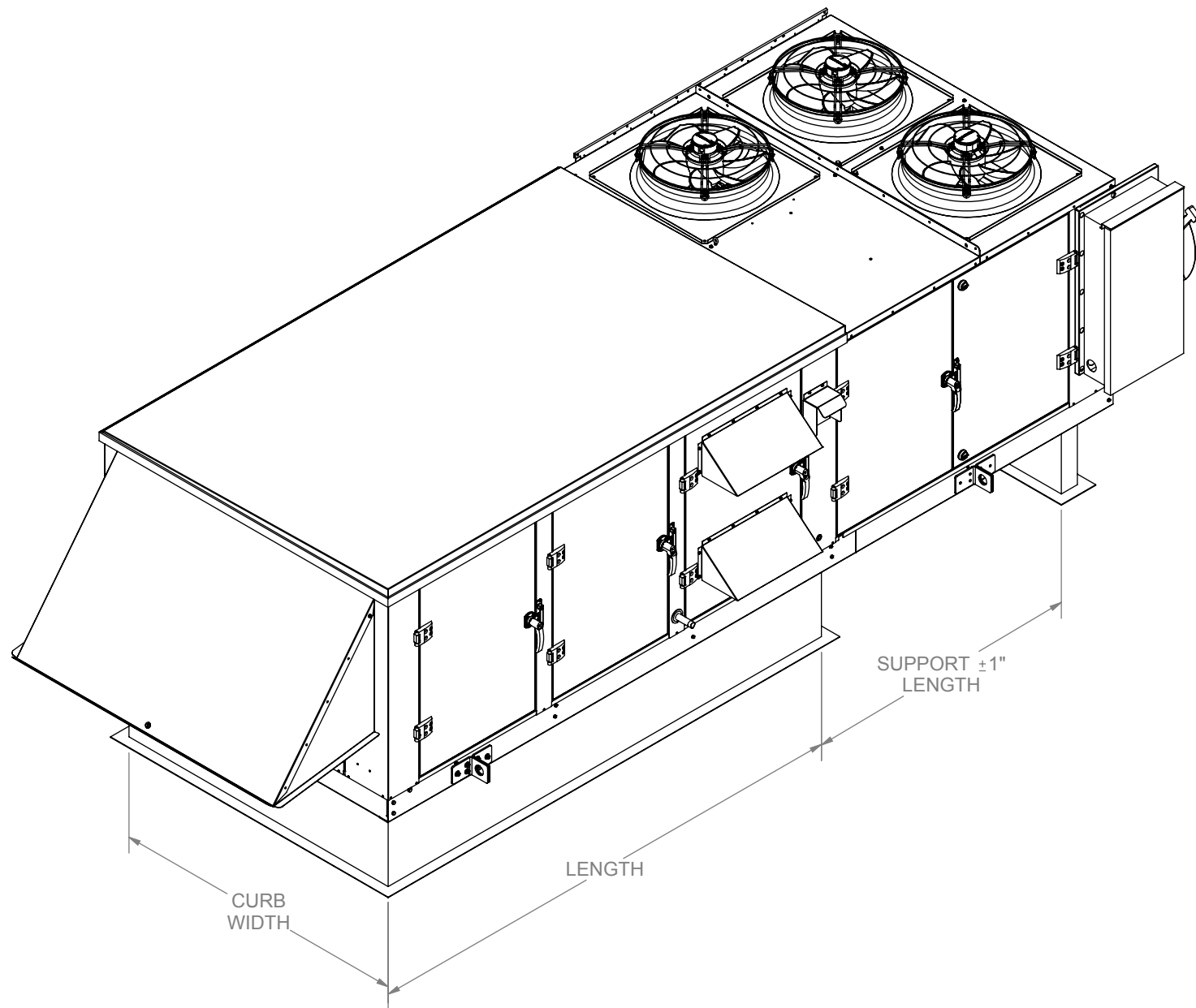

ONE PIECE CURB DETAIL

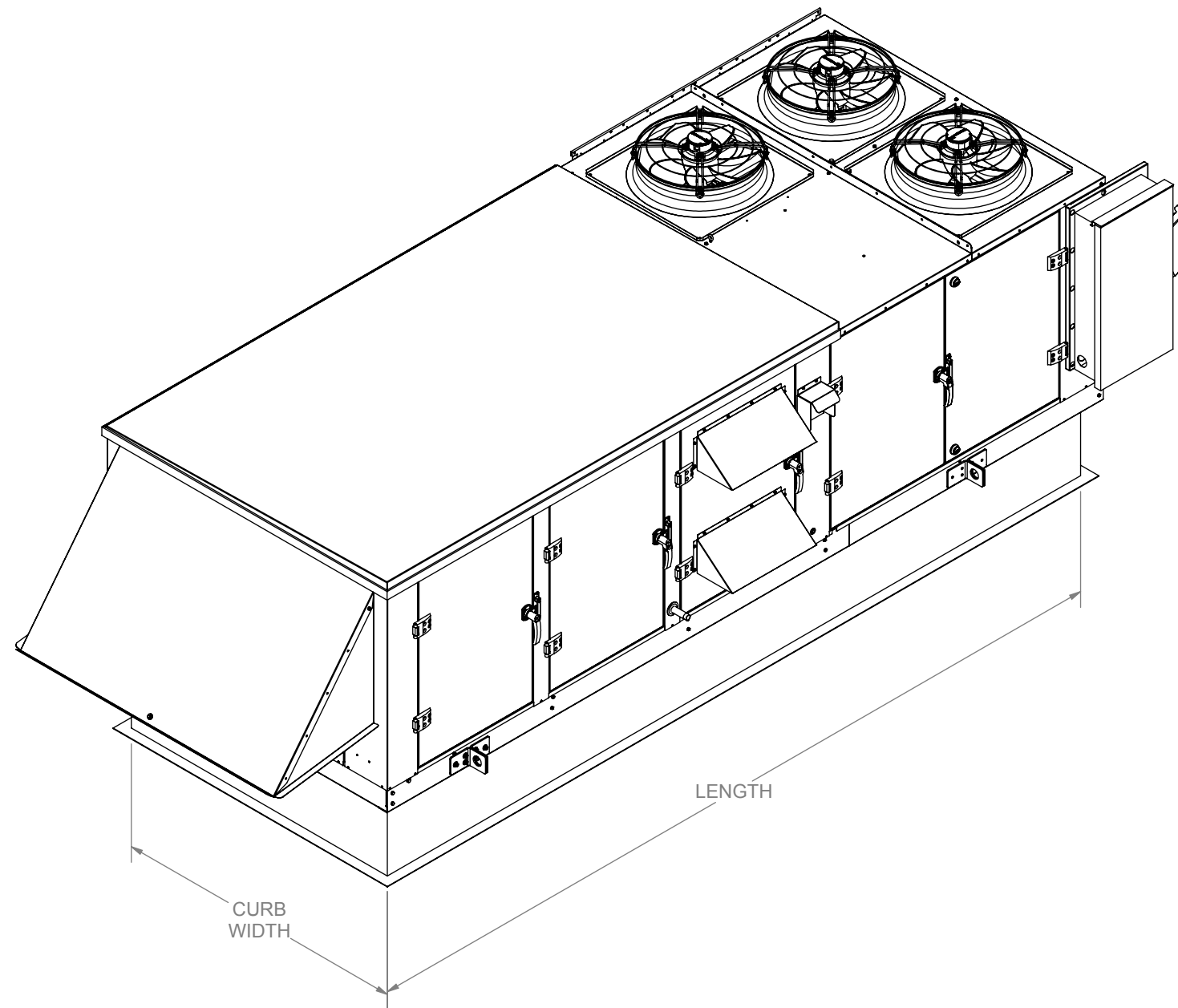

Desert Aire has a policy of continuous product and quality improvement. Specifications and dimensions are subject to change without notice. This drawing and information contained herein are the exclusive property of the Desert Aire Corporation. Any use detrimental to the interests of Desert Aire is prohibited.

ALL DIMENSIONS ARE IN INCHES
TOLERANCE $\pm 1/8"$

All Dimensions in Inches
All Angles 90°
All outside corners 0.125" fillet
Unless Otherwise Specified



Third Angle Projection

Part weight

Tolerance Unless Otherwise Specified
X.X $\pm .125$
X.XX $\pm .060$
X.XXX $\pm .030$
Angles $\pm 1^\circ$

Drawn MHB Date Released 9/8/2011

Sheet 9/9

Scale NTS Rev. 14



N120 W18485 FREISTADT RD
GERMANTOWN, WI 53022
Tel: (262) 946-7400
Fax: (262) 946-7401

Description AURA AIR COOLED PKGD

Page Title CURB OVERVIEW

Drawing Number G806-001